



ITTO PROJECT NO. PD 16/95 REV. 2 (F)

# FOREST HEALTH MONITORING TO MONITOR THE SUSTAINABILITY OF INDONESIAN TROPICAL RAIN FOREST

MOF - ITTO - SEAMEO BIOTROP - USDA Forest Service

## VOLUME III

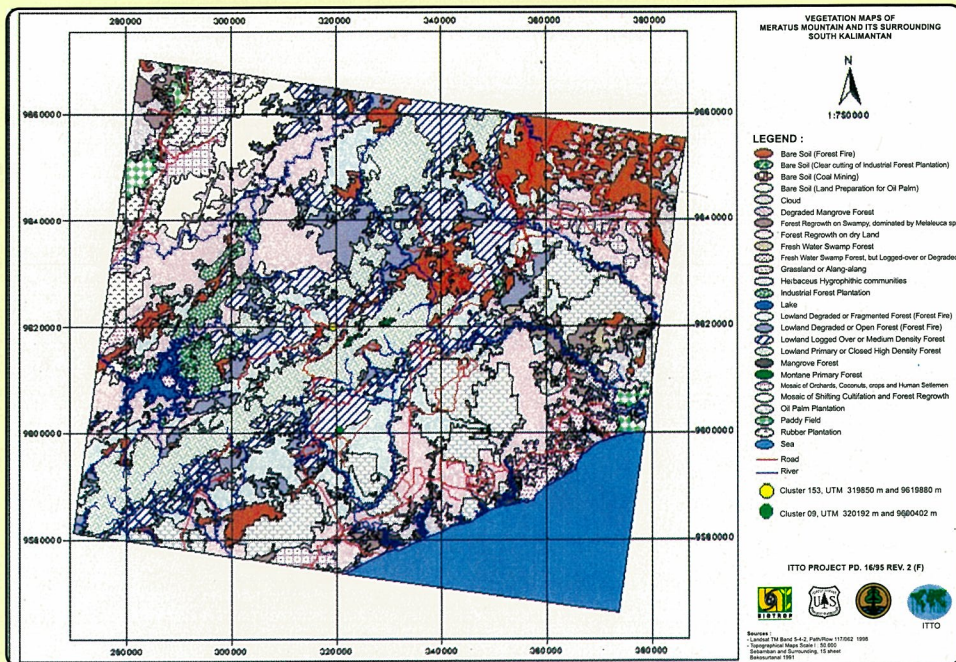

Published by :

ITTO  
International Tropical Timber Organization  
Yokohama, Japan

SEAMEO BIOTROP  
Southeast Asian Regional Center for Tropical Biology  
Bogor, Indonesia

2001

**EDITORIAL BOARD :**

Imelda C. Stuckle  
Chairil Anwar Siregar  
Supriyanto  
Jahya Kartana

**ADDRESS :**

SEAMEO-BIOTROP  
Southeast Asian Regional Center for Tropical Biology  
Jl. Raya Tajur Km. 6, P.O.BOX 116, Bogor, Indonesia  
Phone : +62-251-323848; Fax. : +62-251-326851  
Website : <http://www.biotrop.org>  
e-mail : [info@biotrop.org](mailto:info@biotrop.org)

**Front Cover :** Vegetation map of Meratus Mountain and its surrounding  
South Kalimantan

---



ITTO PROJECT NO. PD 16/95 REV. 2 (F)

# FOREST HEALTH MONITORING TO MONITOR THE SUSTAINABILITY OF INDONESIAN TROPICAL RAIN FOREST

MOF - ITTO - SEAMEO BIOTROP - USDA Forest Service

## VOLUME III

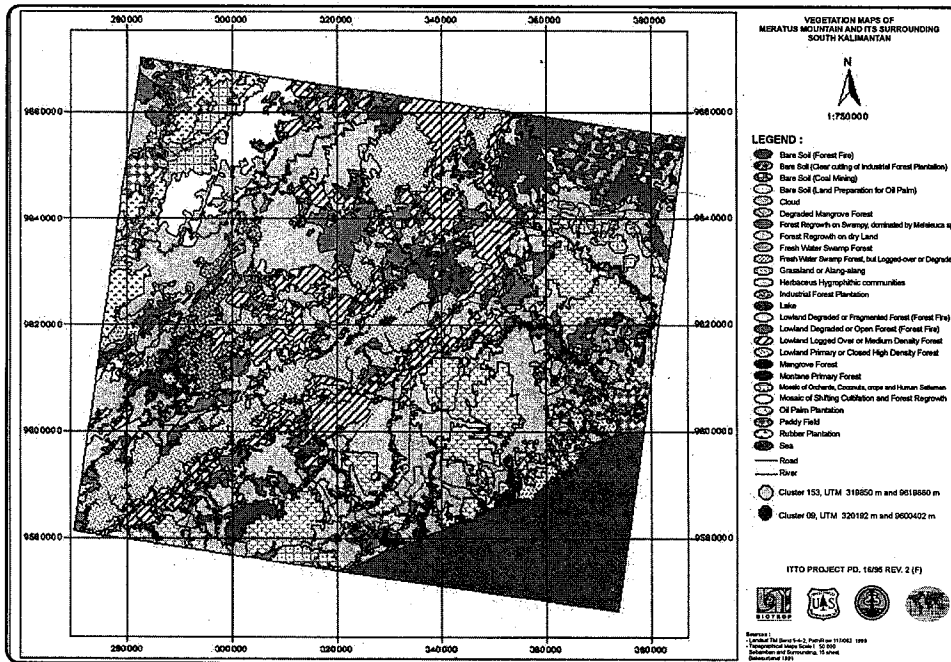

Published by :

ITTO  
International Tropical Timber Organization  
Yokohama, Japan

SEAMEO BIOTROP  
Southeast Asian Regional Center for Tropical Biology  
Bogor, Indonesia

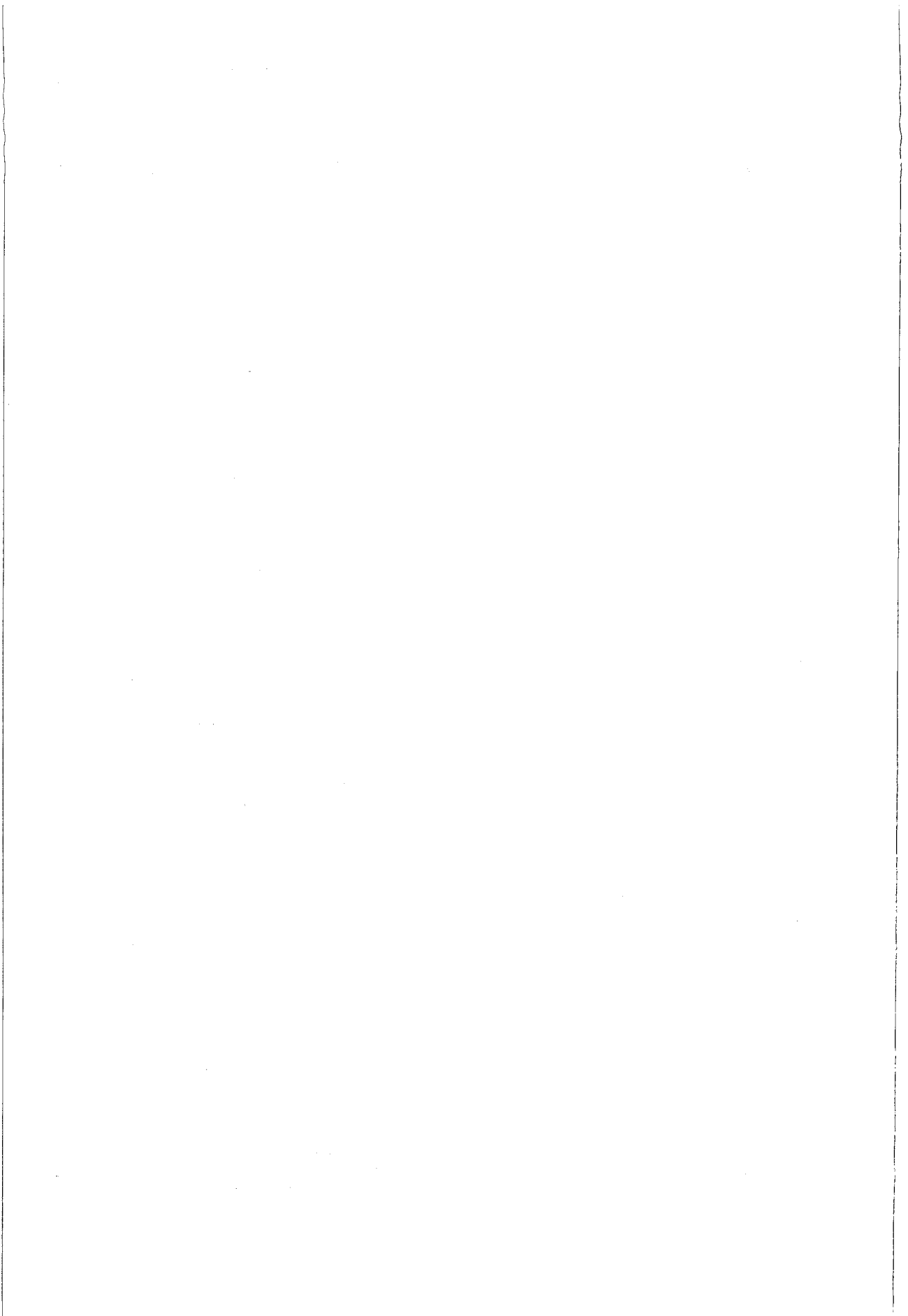



## PREFACE

Changes which occur in the forest ecosystem will always create an impact, positive as well as negative ones. Toward the implementation of ecolabelling, many forest state enterprises and the forest concession holders start reorganizing the future demands to manage forests on sustainable basis. Forests should be managed wisely according to the concept of sustainable forest management.

In 1990, ITTO (International Tropical Timber Organization) has prepared guidelines/indicators on how to manage tropical forests properly. In order to implement those guidelines, SEAMEO-BIOTROP submitted a research project proposal to ITTO entitled Forest Health Monitoring to Monitor the Sustainability of Indonesian Tropical Rain Forests, called INDO-FHM. The objectives of INDO-FHM were to find the attributes, indicators and trends which influence the health and conservation of tropical forest; to establish monitoring plots, demonstration and training plots; technology transfer of FHM methodology and software; and to undertake training programs. Indicators used among others are: (1) Production (growth and mortality, vegetation structures, biotic and abiotic stand damage); (2) Site quality; (3) biodiversity; and (4) Forest vitality (crown structure).

Previously, research activities in Forest Health Monitoring have been carried out only in the temperate forests. Indonesia is the first country to conduct FHM research in the tropical ecosystem.

The INDO-FHM research was conducted from 1996 – 2000, with the financial support from the ITTO, USDA-Forest Service, the Ministry of Forestry of the Republic of Indonesia, and SEAMEO BIOTROP. A series of training was also conducted for the Indonesian crews (85 persons), Indonesian scientists (28 persons), and Southeast Asian scientists (14 persons).

To disseminate the knowledge and experience generated in conducting the research on Forest Health Monitoring, three volumes of Technical Reports were made.

Finally, SEAMEO BIOTROP would like to thank ITTO, USDA-Forest Service, and the Government of Indonesia for their valuable support.

SEAMEO BIOTROP  
Southeast Asian Regional Centre  
for Tropical Biology,

Prof. Dr. H. Sitanala Arsyad  
Director

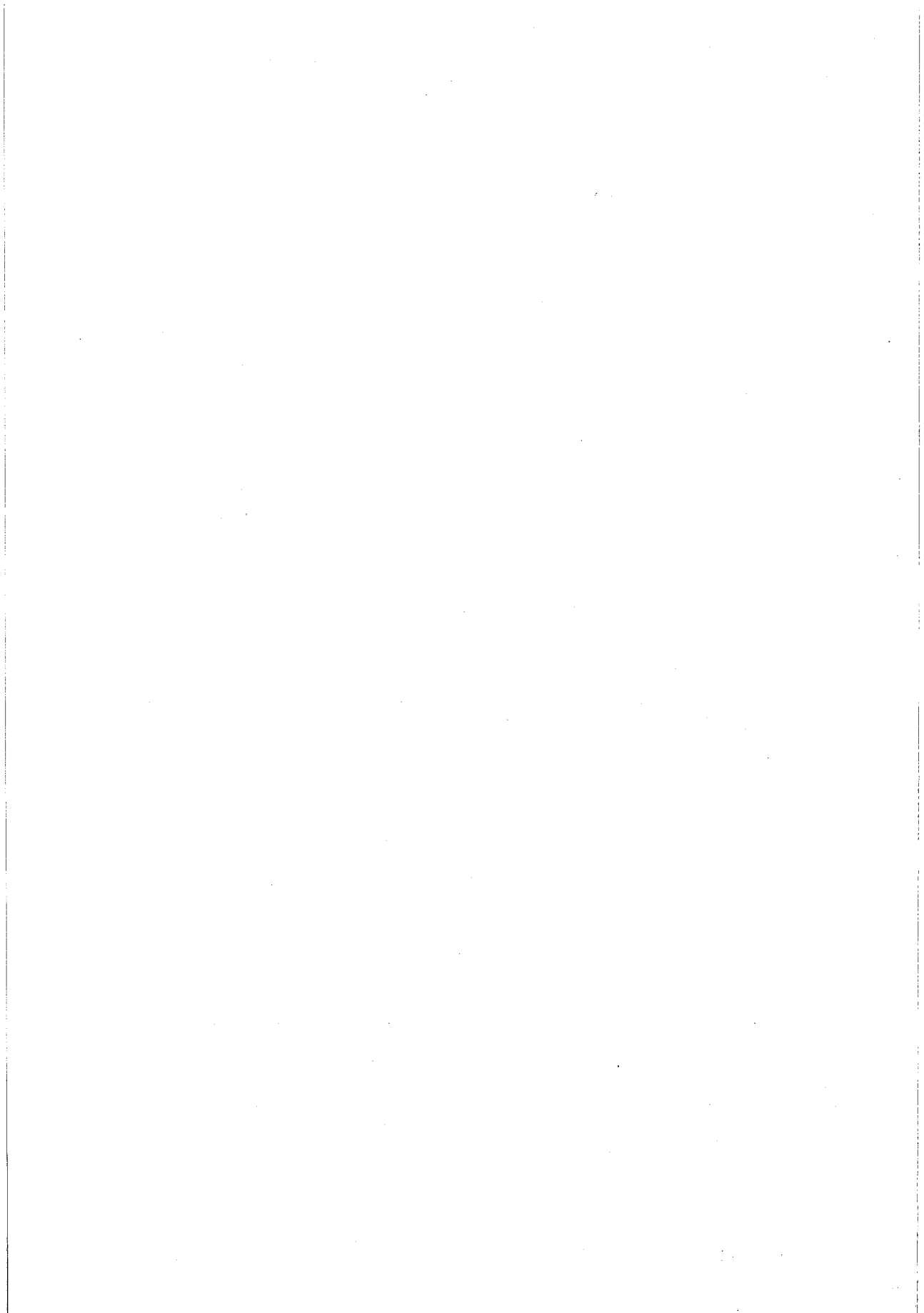

# CONTENTS

<b>Preface</b> .....	i
<b>Contents</b> .....	iii
<b>Site and Species Suitability Study Based on Forest Health Monitoring Activities Conducted in South Kalimantan, Jambi, and East Java</b>	
<i>Chairil Anwar Siregar and Supriyanto</i> .....	1
<b>Stand Structure (Status, Change, Trends)</b>	
<i>Supriyanto, Ujang Susep Irawan, Erianto Indra Putra , I Wayan Susi Dharmawan</i> .....	27
<b>Regeneration and Mortality</b>	
<i>Supriyanto, Ujang S. Irawan, I Wayan S. Dharmawan, Erianto I. Putra</i> .....	41
<b>Assessment on the Modification of FHM Vegetation Quadrates to Address Tropical Species Diversity of Trees</b>	
<i>Uhaedi Sutisna, Erianto Indra Putra, Soekotjo, Djoko Marsono</i> .....	55
<b>A Study of Soil and Vegetation Dominated by <i>Shorea polyandra</i> on Forest Health Monitoring Plots in Pulau Laut</b>	
<i>Chairil Anwar Siregar and Supriyanto</i> .....	73
<b>Assessment of Socio-Economic and Cultural Indicators of Forest Health Monitoring</b>	
<i>Bahrani, Dudung Darusman, Erianto Indra Putra, Djohan Setiawan</i> .....	107
<b>Assessment on Crown Indicators of Forest Health Monitoring</b>	
<i>Kasno, Supriyanto, Simon Taka Nuhamara, Erianto Indra P., I Wayan Susi D. ...</i>	121
<b>Early Warning of Changes in Canopy Condition of Overstory Trees</b>	
<i>Kasno, Simon Taka Nuhamara, Supriyanto, Uhaedi Sutisna, I Wayan Susi D. ...</i>	161

1. The first part of the document discusses the importance of maintaining accurate records of all transactions and activities. It emphasizes that proper record-keeping is essential for ensuring transparency and accountability in financial management.

2. The second part of the document outlines the various methods and techniques used to collect and analyze data. It highlights the need for a systematic approach to data collection and the importance of using reliable sources of information.

3. The third part of the document focuses on the analysis and interpretation of the collected data. It discusses the various statistical and analytical tools that can be used to identify trends and patterns in the data.

4. The fourth part of the document discusses the implications of the findings and the need for further research. It emphasizes that the results of the study should be used to inform decision-making and to guide the development of policies and programs.

5. The fifth part of the document provides a summary of the key findings and conclusions of the study. It highlights the main points of the research and the implications of the findings for practice and policy.

6. The sixth part of the document discusses the limitations of the study and the need for further research. It acknowledges the constraints of the study and the need for more comprehensive and rigorous research in the future.

7. The seventh part of the document provides a list of references and sources used in the study. It includes a variety of academic journals, books, and other sources of information that have informed the research.

8. The eighth part of the document provides a list of appendices and supplementary materials. It includes additional data, tables, and figures that are not included in the main text of the document.

9. The ninth part of the document provides a list of acknowledgments and thanks. It expresses appreciation to the individuals and organizations that have supported the research and provided assistance throughout the study.

10. The tenth part of the document provides a list of contact information and a way to reach the author. It includes the author's name, address, phone number, and email address.

# SITE AND SPECIES SUITABILITY STUDY BASED ON FOREST HEALTH MONITORING ACTIVITIES CONDUCTED IN SOUTH KALIMANTAN, JAMBI, AND EAST JAVA

*Technical Report No. 22*

Chairil Anwar Siregar  
Supriyanto

## ABSTRACT

Soil is but one factor of a habitat, representing the region where a plant community naturally grows. Another significant factor that is inherent to habitat is the climate of a site, influencing a wide array of species grown in a given habitat. Hence, climate and soil are the two principal criteria that determine habitat suitability for a particular tree species. In this regard, site and species suitability has been an important forestry study ever since the development of tropical plantation forest was initiated two decades ago. Hence, the objective of this paper is to synthesize habitat suitability of forestry species by employing soil information collected from forest health monitoring activities. The forest health monitoring associated with the soil indicator study was carried out in four study sites namely: PT INHUTANI II in South Kalimantan, and PT Asialog in Jambi, lasting from 1996 to 1999; and PT Sumpol in South Kalimantan and Perum Perhutani Unit II in Kediri, lasting in 1999. A summary of the synthesis of species and habitat suitability is proposed. It covers 49 tree species mostly grown in tropical areas with altitude ranging from 0 to 3000 meters above sea level, receiving average annual rainfall varying from 500 to 5000 mm, and with soil reaction that is mostly acidic bearing generally low status of chemical fertility as in the case of typical tropical soils.

**Key words:** *Soil, habitat suitability, forest health monitoring, tropical species*

## I. INTRODUCTION

Regarded as a product of environment, soil is the natural medium for the growth of a huge number of plants; it provides a foothold, as well as water and nutrients required to support plant growth and development. In his famous book, *Factors of Soil Formation*, Hans Jenny in 1940 espoused that soil is a function of climate, organisms, parent material, relief and time. This soil formulation implicitly indicates that development of soil and associated forest vegetation has not been a simple and straightforward process. While a number of relatively independent factors are involved in the development of soil and vegetation as well, none is plausibly more critical than climate. This is to say that climate, vegetation, and soil form an intimate and interrelated dynamic complex.

Theoretically, it seems relatively simple to specify the plant-producing capacity of a soil in terms of its physical and chemical properties. This specification, however, is not simple. Many scientists have emphasized the fact that soil productivity is determined by the integrated effect of all its characters, rather than by the magnitude of any one.



Moreover, Lutz and Chandler (1961) emphasize that the farther a tree species is removed from the region of its climatic optimum, the more discriminating it becomes in regard to soil. Hence the soil factor happens to be increasingly significant in the vicinity of the limits of the climatic range of a given species.

Site and species suitability has been an important forestry issue ever since the development of tropical plantation forest was initiated two decades ago. Prior to deciding choice of species in the plantation project, at least three significant inquiries should be examined including the purpose of plantation, species which are potentially available, and site species matching (Evans, 1984).

The four main purposes of plantation establishment are industrial uses, domestic uses, environmental protection, and tree planting as an integral part of other land-uses for amenity, shade, shelter, fruits and nuts, fodder and browse. Furthermore, potentially available species is one aspect corresponding to the possibilities and limitations in species selection under the headings indigenous species, exotic species, and tree improvement. Meanwhile site species matching is dealing with achieving the best match between species (variety and provenance) and the planting site.

Soil is but one factor of a habitat, representing the region where a plant community naturally grows. Another significant factor that is inherent to habitat is climate of a site, influencing a given habitat for wide arrays of species grown. Hence, climate and soil are two principal criteria determining habitat suitability to a particular tree species.

Two components of the climate are prevailing importance when selecting a tree species to grow namely, amount and distribution of rainfall, and temperature extremes. Meanwhile principal soil properties affecting species selection are soil depth, and soil physical and chemical properties. This paper, will briefly discuss habitat suitability to tree species integrating several soil and climate descriptors with reference to forest health monitoring study conducted in South Kalimantan, Jambi, and East Java.

## **II. MATERIALS AND METHODS**

### **2.1. Location**

The forest health monitoring associated with soil indicators study was carried out in four study sites namely P.T. INHUTANI II in South Kalimantan, and P.T. Asialog in Jambi, lasting from 1996 to 1999, and P.T. Sumpol in South Kalimantan and Perum Perhutani Unit II in Kediri, lasting in 1999. General information of each FHM study site is provided below.

### **2.1.1. PT INHUTANI II**

P.T. INHUTANI II is located in Pulau Laut, a small island that belongs to South Kalimantan Province. The FHM plots were established in Buffer Zone, which was logged in 1978 (clusters 1 and 7), Biodiversity Conservation Area (cluster 2), Dipterocarp Plantation (cluster 3) and Seed Production Areas (clusters 4, 5, and 6). The soil order falls under Oxisols and Ultisols, with topographical condition ranging from flat to hilly and dissected with slope > 50 %. Some important physical and chemical nature of the soil are moderately fine (topsoil) and fine (subsoil), shallow to very shallow, high exchangeable Ca and Mg, medium to high exchangeable K, low exchangeable Na, low to medium CEC, acid to slightly acid in soil reaction, and low Al saturation.

Based on the criteria of Schmidt and Ferguson, the climate in the project site is categorized under Type A with annual rainfall ranging from 2429 to 2492 mm. The rainy season occurs in December to June with monthly rainfall average of more than 250 mm, while the dry season occurs in July to November with monthly rainfall average of 150 mm.

### **2.1.2. PT Asialog**

PT Asialog is located in Jambi and the FHM plots were established in Limited Production Forest (clusters 1, 2, 3 and 4). The soil order falls under Oxisols and Ultisols, with topographical condition is varying from flat to wavy with slope 5-10 %. Some important physical and chemical nature of the soil are moderately coarse (topsoil) and moderately fine (subsoil), thick to very thick, very low to low exchangeable Ca, low to medium exchangeable Mg, low exchangeable K, low to medium exchangeable Na, low to medium CEC, very strong acid to strong acid in soil reaction, and low Al saturation.

Based on the criteria of Schmidt and Ferguson, the climate in the project site is categorized under Type A with annual rainfall average of 2248 mm, and the average daily temperature is 26.5 °C with relative humidity 84 %.

### **2.1.3. PT Sumpol**

PT Sumpol is located in South Kalimantan, and the FHM plots were established in Limited Production Forest (clusters 8 and 9). The soil order falls under Oxisols, with topographical condition ranging from flat to hilly and dissected with slope > 50 %. Some important physical and chemical nature of the soil are moderately coarse (topsoil) and moderately fine (subsoil), thick to very thick, very low to medium exchangeable Ca, high exchangeable Mg, low exchangeable K, low exchangeable Na, low CEC, very strong acid to strong acid in soil reaction, and low Al saturation.

Based on the criteria of Schmidt and Ferguson, the climate in the project site is categorized under Type B with annual rainfall averaging at 2,485 mm. The average rainfall during rainy season is 288 mm, meanwhile the average rainfall during dry season is 177 mm. The wettest month occurs on January with 354 mm rainfall. Average daily temperature is 29 °C with relative humidity ranging from 72-95 %.

#### **2.1.4. Perum Perhutani**

Perum Perhutani Unit II is located in Kediri, and the FHM plots were established in *P. falcataria* plantation forest (clusters 1, 2, 3, 4, and 5). The soil order falls under Ultisols, with topographical condition varying from flat to wavy with slope 5-10 %. Some important physical and chemical nature of the soil are moderately coarse (topsoil) and moderately fine (subsoil), thick to very thick, low exchangeable Ca, low exchangeable Mg, low to medium exchangeable K, low exchangeable Na, very low to low CEC, strong acid in soil reaction, and low Al saturation.

The study site is located at 200 m above sea level, and receives average annual rainfall of 1500 mm with air temperature ranging from 22 ° – 32 °C and relative humidity ranging from 50-70 %.

#### **2.2. Location of Sampling Points**

The plot establishment procedure, as described by USDA Forest Service (1999), was applied to each cluster under investigation. Soil sampling sites are located on soil sampling lines adjacent to subplots 2,3, and 4 on the FHM plot (Figure 1). The location of a soil sampling site on the soil sampling line is determined by the number of times a plot has previously been sampled. The forest floor layers (litter layer and organic soil layer – if present) are sampled at only one soil sampling site on each plot. The primary location is the soil sampling site associated with subplot 2. If no litter layer is found at the sampling site on subplot 2, proceed to subplot 3. Proceed to subplot 4, if necessary.

Mineral soil samples are taken from three soil sampling sites and composite by depth layers into individual soil samples for analysis. Locate the three soil sampling sites using the following procedure:

- From the center of Subplot 2 of the FHM plot, measure 30 ft (9.2 m) on an azimuth of 180 degrees or due south. Mark the soil sampling site with flagging. This is soil sampling site for visit number 1 to the subplot 2 soil sampling line.
- From the center of Subplot 3 of the FHM plot, measure 30 ft (9.2 m) on an azimuth of 300 degrees (northwest). Mark the soil sampling site with flagging. This is soil sampling site for visit number 1 to the subplot 3 soil sampling line. Mineral soil

samples are taken from three soil sampling sites and composite by depth layers into individual soil samples for analysis.

- From the center of Subplot 4 of the FHM plot, measure 30 ft (9.2 m) on an azimuth of 60 degrees(northeast). Mark the soil sampling site with flagging. This is soil sampling site for visit number 1 to the subplot 4 soil sampling line.

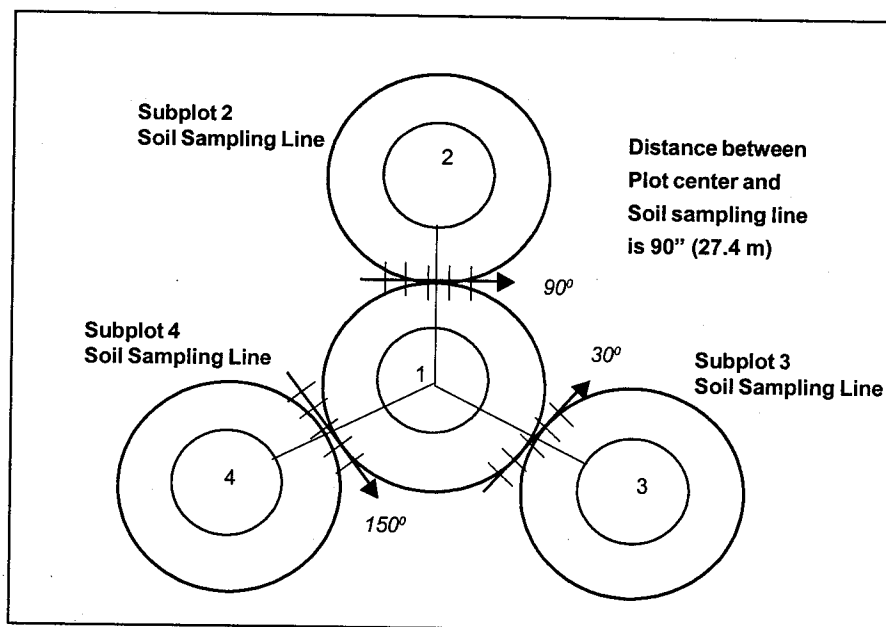

Figure 1. Location of soil sampling lines

During the first visit to a plot for soil sampling, soil sampling site with visit number 1 will be used for soil depth measurements and to collect soil samples. On subsequent visits to a plot, soil sampling sites with number 2 or larger will be used (depending on the number of times a plot has previously been sampled).

Proceed to the location of the appropriate sampling site along a soil sampling line. If it appears that a soil sample can be taken, place a small plastic tarp on the ground beside the sampling point.

### 2.3. Measuring and Sampling Procedures

#### 2.3.1. Organic Layers

Proceed to sampling point 1. Place a plastic tarp on the ground beside the sampling point. Sample the organic surface material as follows. Place a sampling frame of known area (e.g., 0.3 m<sup>2</sup>) over the sampling point. Using a sharp knife, carefully cut

through the organic soil surface along the inner surface on the frame to separate it from the surrounding soil. Carefully remove any live forbs, grasses or shrubs and all living above-ground vegetation from the sample area. Using inward scooping motions, carefully remove the entire volume of O horizon material from within the confines of the sampling frame. Working over the tarp, place the entire O horizon sample into a pre-labeled 8-L sample bag. In some areas more than one bag might be required to hold the sample. If so, label the bags with identical information, then add "1 of 2" and "2 of 2", respectively. Make sure the bag is properly labeled and then seal it securely. The O horizon is sampled only at sampling point 1.

Measure the thickness of the O horizon to the nearest cm at four points on the outer perimeter of the sampled area. Locate these points due north, due east, due south and due west. Determine the mean of the four measurements and record it.

### **2.3.2. Mineral Surface Layers**

After exposing the top of the mineral surface layer (A horizon) by removing the O horizon, use a tile spade or entrenching tool to excavate a soil pit approximately 30 cm on a side and deep enough to expose the boundary between the soil surface and the subsoil. Do not excavate deeper than 50 cm. Record the thickness of the A horizon (lighter texture; colored brownish from organic material leached in from O horizon) and the depth to the subsoil (usually the "B" horizon; generally heavier textured and brighter yellow or red color) to the nearest cm. Measure the A horizon thickness and the depth to the subsoil at the four points on the outer perimeter of the sampled area. Locate these points due north, due east, due south, and due west. Determine the means of each set of four measurements and record them. If the subsoil is not encountered within a depth of 50 cm, record depth to the subsoil as "more than 50 cm."

Smooth and clean one face of the pit for sampling. Measure from the surface of the mineral soil to the bottom of the A horizon and mark the boundary with a knife. Then measure 10 cm below the bottom of the A horizon (often the "E" horizon; similar texture to A but without organic material leached in) and mark this boundary. Remove approximately 150 cc (about 2 handfuls) of soil from the A horizon and place it in a pre-labeled 2-L sample bag. Then remove approximately 150 cc of soil from the underlying 10 cm layer and place it in a second 2-L sample bag. Estimate the texture of the second layer and record it as loamy, clayey or sandy. If possible, discard rock fragments larger than approximately 20 mm (3/4 in) in diameter (coarse pebbles or larger) from all soil samples. Discard root fragments also.



After the sampling and measurements are completed, place the soil back in the pit in its original layer sequence. Try to restore the sample point as similar to its original condition as possible. Proceed to sampling point 2.

At sampling point 2, lay the tarp down beside the area to be sampled. Remove the organic surface layer and place it on the tarp, but do not sample it. Prepare a sampling pit as before. Sample the A horizon, placing approximately 150 cc of soil into the same 2-L bag containing the A horizon sample from point 1. Shake the bag to mix the samples. Then sample the underlying 10 cm layer as before, placing approximately 150 cc of soil in the same 2-L bag containing the second mineral sample from point number 1. Shake the bag to mix the samples. Estimate the texture of both the A horizon and the underlying 10 cm layer, recording texture as clayey, loamy or sandy. As before, record the thickness of the A horizon and the depth to the subsoil to the nearest cm. If the subsoil is not encountered within a depth of 50 cm, record depth to the subsoil as "more than 50 cm".

After restoring the site at sampling point 2, proceed to sampling point 3. Repeat the procedure followed at sampling point 2. Seal the sample bags and make sure they are properly labeled with the state, hex number, layer sampled, date, and crew identification.

#### **2.4. Laboratory Analyses**

Soil samples collected from the field are analyzed in the laboratory to determine the following:

- Mineral soil samples:
  - pH in water and in KCl
  - Total organic carbon
  - Exchangeable Ca, Mg, K, and Na
  - Bray I Phosphorus
  - CEC and BS
  - Texture (optional)
- Organic layers:
  - Total organic carbon
  - Total N
  - Percentage organic matter (Loss on ignition, LOI)

### **III. RESULTS AND DISCUSSIONS**

#### **3.1. Soil Chemical and Physical Characteristic Changes**

Soil chemical properties of Pulau Laut study site for both years (1996 and 1999) are presented in Table 1. The trend of soil reaction was altered toward more acidic over

time. The decrease in soil organic carbon and total nitrogen was also apparent. Note also that the depletion of soil organic matter content is consistent with considerable decrease of exchangeable bases, particularly Ca, and Bray I extractable P. Generally, the status of soil chemical properties decreased with soil depth; however, considerable random variations within time of observation was evident. Soil texture of this site is classified as clay, and in most cases, the accumulation of clay particle is detected on the lower soil layer (B horizon).

The summary of soil chemical properties collected from the Jambi study for both years (1996 and 1999) is presented in Table 2. There is no substantial changes over time in soil pH, soil organic carbon, extractable basic cation and CEC. Yet, tremendous decrease in LOI with time was obvious and this suggests that intensive decomposition of organic matter occurred in soil O horizon. The cause of higher base saturation (BS) in 1999 is obscure, but the increase in BS with time was consistently observed throughout all clusters 1 and 2 in Jambi. Moreover, there are considerable variations among the data of exchangeable basic cations and CEC, and some of the significant differences are of questionable value. Soil texture of this monitoring site varies from loam, sandy loam, silty loam to clay loam.

The feature of soil fertility level as reflected by soil chemical properties of Sumpol, is presented in Table 3. Soil organic carbon and total nitrogen level are categorized into medium. Exchangeable Ca and Mg are classified into low and high, respectively. Eventhough BS level ranges from medium to high, the CEC level is considerably low and hence, in general the soil has poor soil fertility. Soil texture of Sempol study is classified as clay.

The degree of soil fertility of the study site in Kediri as reflected by soil chemical properties is shown in Table 4. The soil organic carbon, total nitrogen, exchangeable basic cations and CEC are typically low, but BS level is significantly high. As in the case of Sumpol, the soil of FHM plots in Kediri is also bearing poor chemical fertility. Soil texture of this monitoring site is sandy.

Soil organic matter, as one of important soil properties equipped in the assessment of forest health condition, is described by total organic carbon and percent of organic matter (LOI). The decrease in soil organic matter at the expense of the increase in tree growth indicated by increase in basal area with time (Table 5) was observed in Pulau Laut and Jambi. Note that the lower basal area in 1999 as compared to that of in 1996 resulted at Clusters 4, 5, 6 (Pulau Laut), and at Cluster 2 (Jambi) due to the fact that corresponding sites were burnt causing the tree mortality.

### **3.2. Approach to Habitat Suitability**

Most critical environmental factors affecting plant growth includes climate, soil and altitude (elevation of site above sea level). This section below briefly summarizes the importance of climate and soil in relation to potential biological productivity of land to support growth and development of a specific crop so as to reach the possible range of habitat suitability.

Table 1. Soil chemical properties of Pulau Laut, 1996 and 1999

Location, Year	Cluster	Hor.	pH		C org	N tot	LOI	C / N	Ca	Mg	Na	K	P	CEC	BS	Al	H	Sand	Silt	Clay
			H <sub>2</sub> O	KCl																
P. Laut, 1996	1	A	7.1	6.9	4.70	0.69	-	6.81	24.83	9.98	-	0.89	31.11	-	-	-	-	-	-	-
P. Laut, 1996	1	B	7.0	6.1	4.10	0.61	-	6.72	12.69	5.17	-	0.98	7.34	-	-	-	-	-	-	-
P. Laut, 1996	2	A	7.4	7.1	5.40	0.82	-	6.59	34.69	7.81	-	0.93	44.68	-	-	-	-	-	-	-
P. Laut, 1996	2	B	7.0	6.4	3.50	0.50	-	7.00	20.95	3.28	-	0.54	28.12	-	-	-	-	-	-	-
P. Laut, 1996	3	A	6.5	5.0	4.45	0.67	-	6.64	20.19	6.58	-	0.96	24.60	-	-	-	-	-	-	-
P. Laut, 1996	3	B	5.2	5.6	1.70	0.25	-	6.80	3.26	1.54	-	0.24	25.42	-	-	-	-	-	-	-
P. Laut, 1996	4	A	6.7	4.0	2.00	0.30	-	6.67	9.19	2.59	-	0.42	20.40	-	-	-	-	-	-	-
P. Laut, 1996	4	B	5.3	5.4	1.15	0.16	-	7.19	1.84	1.03	-	0.14	2.47	-	-	-	-	-	-	-
P. Laut, 1996	5	A	6.5	5.4	4.35	0.77	-	5.65	9.80	5.68	-	1.17	12.65	-	-	-	-	-	-	-
P. Laut, 1996	5	B	4.5	3.5	1.05	0.16	-	6.56	0.92	0.93	-	0.40	20.61	-	-	-	-	-	-	-
P. Laut, 1996	6	A	6.9	5.8	3.40	0.52	-	6.54	6.18	3.64	-	0.66	10.99	-	-	-	-	-	-	-
P. Laut, 1996	6	B	4.6	3.6	1.00	0.14	-	7.14	1.37	0.65	-	0.16	18.80	-	-	-	-	-	-	-
P. Laut, 1996	7	A	7.3	6.4	3.85	0.67	-	5.75	28.19	10.09	-	1.07	42.96	-	-	-	-	-	-	-
P. Laut, 1996	7	B	6.3	5.1	1.15	0.18	-	6.39	7.80	4.21	-	0.60	24.04	-	-	-	-	-	-	-

Remark: - data not available

Table 1. (Continuation)

Location, Year	Cluster	Hor.	pH		C org	N tot	LOI	C / N	Ca	Mg	Na	K	P	CEC	BS	Al	H	Sand	Silt	Clay
			H <sub>2</sub> O	KCl																
P. Laut, 1999	1	A	5.2	4.5	3.84	0.33	11.64	18.99	2.80	3.64	0.22	0.55	8.09	21.24	33.95	0.19	0.12	13.76	38.32	47.92
P. Laut, 1999	1	B	5.2	4.1	1.55	0.16	10.33	15.56	2.32	3.34	0.22	0.48	5.69	18.11	35.12	0.06	0.16	17.53	27.59	54.88
P. Laut, 1999	2	A	6.5	5.7	3.70	0.35	10.59	9.27	8.15	4.26	0.20	0.58	5.31	16.65	79.23	0.23	0.01	22.72	30.03	47.25
P. Laut, 1999	2	B	6.2	5.4	1.67	0.20	8.24	9.70	4.06	3.30	0.12	0.53	3.93	10.90	73.46	0.18	0.01	25.41	30.06	44.53
P. Laut, 1999	3	A	5.6	4.8	3.50	0.33	10.76	15.89	5.90	6.42	0.62	0.72	7.17	23.37	58.46	0.06	0.01	21.65	33.42	44.93
P. Laut, 1999	3	B	4.7	4.2	1.49	0.15	9.93	15.64	2.13	2.34	0.20	0.34	6.83	17.01	29.45	0.43	0.03	18.07	31.54	50.39
P. Laut, 1999	4	O	6.7	6.0	22.46	1.09	20.54	41.10	10.62	12.42	1.68	5.17	21.98	37.47	79.77	0.53	0.25	6.24	31.63	62.13
P. Laut, 1999	4	A	5.6	5.5	3.13	0.26	12.04	12.05	2.22	3.54	0.22	1.18	5.18	9.30	77.01	0.36	0.18	11.62	21.23	67.15
P. Laut, 1999	4	B	5.2	4.5	1.17	0.13	9.22	8.15	0.73	1.52	0.29	1.06	3.79	6.50	55.39	2.39	0.88	5.36	20.44	74.20
P. Laut, 1999	5	A	5.2	4.9	2.15	0.18	11.68	11.18	1.56	2.74	0.42	1.12	6.32	7.55	77.37	2.12	0.39	4.99	26.69	68.32
P. Laut, 1999	5	B	4.2	4.7	1.09	0.11	9.53	6.61	0.24	0.64	0.11	0.43	1.43	6.49	21.43	3.97	1.06	19.10	32.68	48.22
P. Laut, 1999	6	A	5.3	4.7	2.37	0.24	9.88	10.29	1.18	1.18	0.34	0.62	6.55	6.26	67.89	2.53	1.20	14.49	33.14	52.37
P. Laut, 1999	6	B	4.8	4.5	1.79	0.18	9.93	6.02	0.36	0.36	0.28	0.38	5.30	3.52	48.01	1.78	0.65	2.58	25.54	71.89
P. Laut, 1999	7	A	5.7	5.2	3.58	0.30	11.95	19.96	4.06	3.34	1.09	0.53	16.35	18.63	48.42	0.13	0.03	16.41	36.34	47.52
P. Laut, 1999	7	B	4.9	4.5	2.16	0.22	9.82	14.80	2.99	5.03	0.17	0.50	10.15	19.70	44.11	0.33	0.02	12.91	31.61	55.48



Table 2. Soil chemical properties of Jambi, 1996 and 1999

Location, Year	Cluster	Hor.	pH		C org	N tot	LOI	C / N	Ca	Mg	Na	K	P	CEC	BS	Al	H	Sand	Silt	Clay
			H <sub>2</sub> O	KCl																
P. Laut, 1999	1	A	5.2	4.5	3.84	0.33	11.64	18.99	2.80	3.64	0.22	0.55	8.09	21.24	33.95	0.19	0.12	13.76	38.32	47.92
P. Laut, 1999	1	B	5.2	4.1	1.55	0.16	10.33	15.56	2.32	3.34	0.22	0.48	5.69	18.11	35.12	0.06	0.16	17.53	27.59	54.88
P. Laut, 1999	2	A	6.5	5.7	3.70	0.35	10.59	9.27	8.15	4.26	0.20	0.58	5.31	16.65	79.23	0.23	0.01	22.72	30.03	47.25
P. Laut, 1999	2	B	6.2	5.4	1.67	0.20	8.24	9.70	4.06	3.30	0.12	0.53	3.93	10.90	73.46	0.18	0.01	25.41	30.06	44.53
P. Laut, 1999	3	A	5.6	4.8	3.50	0.33	10.76	15.89	5.90	6.42	0.82	0.72	7.17	23.37	58.46	0.06	0.01	21.65	33.42	44.93
P. Laut, 1999	3	B	4.7	4.2	1.49	0.15	9.93	15.64	2.13	2.34	0.20	0.34	6.83	17.01	29.45	0.43	0.03	18.07	31.54	50.39
P. Laut, 1999	4	O	6.7	6.0	22.46	1.09	20.54	41.10	10.62	12.42	1.68	5.17	21.98	37.47	79.77	0.53	0.25	6.24	31.63	62.13
P. Laut, 1999	4	A	5.6	5.5	3.13	0.26	12.04	12.05	2.22	3.54	0.22	1.18	5.18	9.30	77.01	0.36	0.18	11.62	21.23	67.15
P. Laut, 1999	4	B	5.2	4.5	1.17	0.13	9.22	8.15	0.73	1.52	0.29	1.06	3.79	6.50	55.39	2.39	0.88	5.36	20.44	74.20
P. Laut, 1999	5	A	5.2	4.9	2.15	0.18	11.68	11.18	1.56	2.74	0.42	1.12	6.32	7.55	77.37	2.12	0.39	4.99	26.69	68.32
P. Laut, 1999	5	B	4.2	4.7	1.09	0.11	9.53	6.61	0.24	0.64	0.11	0.43	1.43	6.49	21.43	3.97	1.06	19.10	32.68	48.22
P. Laut, 1999	6	A	5.3	4.7	2.37	0.24	9.88	10.29	1.18	1.18	0.34	0.62	6.55	6.26	67.89	2.53	1.20	14.49	33.14	52.37
P. Laut, 1999	6	B	4.8	4.5	1.79	0.18	9.93	6.02	0.36	0.36	0.28	0.38	5.30	3.52	48.01	1.78	0.65	2.58	25.54	71.89
P. Laut, 1999	7	A	5.7	5.2	3.58	0.30	11.95	19.96	4.06	3.34	1.09	0.53	16.35	18.63	48.42	0.13	0.03	16.41	36.34	47.52
P. Laut, 1999	7	B	4.9	4.5	2.16	0.22	9.82	14.80	2.99	5.03	0.17	0.50	10.15	19.70	44.11	0.33	0.02	12.91	31.61	55.48

Remark: - data not available

Table 3. Soil chemical properties of Sumpol, 1999

Location	Cluster	Hor.	pH		C org	N tot	LOI	C / N	Ca	Mg	Na	K	P	CEC	BS	Al	H	Sand	Silt	Clay
			H <sub>2</sub> O	KCl																
Sumpol	8	A	4.9	4.3	3.68	0.32	11.50	15.88	5.88	4.29	0.18	0.23	10.65	11.55	91.60	0.84	0.16	20.07	30.82	49.11
Sumpol	8	B	4.8	4.1	2.33	0.25	9.32	13.45	3.77	4.06	0.20	0.83	8.41	12.13	50.95	0.35	0.20	30.32	25.95	43.73
Sumpol	9	A	5.1	4.5	3.19	0.34	9.38	27.78	1.23	4.59	0.15	0.21	16.23	14.38	58.83	3.58	0.04	16.74	29.05	54.21
Sumpol	9	B	4.9	4.1	2.56	0.24	10.68	20.63	0.83	4.77	0.14	0.19	18.05	12.24	48.45	0.95	1.04	29.40	24.14	45.46

Table 4. Soil chemical properties of Kediri, 1999

Location	Cluster	Hor.	pH		C org	N tot	LOI	C / N	Ca	Mg	Na	K	P	CEC	BS	Al	H	Sand	Silt	Clay
			H <sub>2</sub> O	KCl																
Kediri	1	O	5.3	4.4	5.90	0.42	13.05	14.10	6.15	3.45	0.23	0.86	38.46	13.75	77.75	0.08	0.02	91.14	9.22	2.64
Kediri	1	A	5.0	4.1	1.94	0.18	5.63	10.58	1.80	0.71	0.27	0.69	31.84	5.32	65.22	0.06	0.05	90.25	7.52	2.33
Kediri	1	B	4.9	4.0	1.62	0.17	8.14	9.56	1.70	1.16	0.26	0.41	26.35	4.82	73.32	0.22	0.05	87.07	7.50	5.43
Kediri	2	O	5.3	4.5	3.02	0.22	8.14	13.48	3.03	1.70	0.21	0.55	46.47	6.89	79.68	0.11	0.01	92.14	5.93	1.93
Kediri	2	A	5.2	4.1	1.79	0.16	4.90	11.21	2.79	1.01	0.23	0.34	34.54	5.16	84.89	0.09	0.02	92.11	5.62	2.27
Kediri	2	B	4.8	3.8	1.83	0.18	6.33	10.04	1.90	0.30	0.26	0.64	26.42	4.00	77.50	0.37	0.01	91.30	6.74	1.96
Kediri	3	O	5.1	4.5	3.30	0.24	5.96	13.57	4.53	0.79	0.19	0.40	44.88	8.63	68.37	0.11	0.03	89.62	5.48	4.90
Kediri	3	A	4.9	4.0	1.76	0.19	4.59	9.15	1.77	0.25	0.19	0.27	40.78	3.76	65.96	0.27	0.02	90.22	7.24	2.54
Kediri	3	B	4.9	3.9	1.34	0.18	6.24	7.53	1.41	0.37	0.26	0.34	29.62	3.89	61.18	0.16	0.02	92.99	4.75	2.26
Kediri	4	O	5.4	4.7	3.37	0.33	8.66	10.27	5.58	2.85	0.18	0.63	51.64	10.50	87.90	0.06	0.01	92.50	4.56	2.94
Kediri	4	A	5.3	4.5	1.84	0.13	3.55	14.63	1.46	0.18	0.15	0.17	42.25	3.53	55.52	0.15	0.03	90.56	7.31	2.13
Kediri	4	B	5.2	4.2	1.19	0.09	3.45	13.03	1.15	0.65	0.23	0.32	20.94	3.17	74.13	0.06	0.05	90.75	4.08	4.17
Kediri	5	O	5.6	4.9	3.25	0.32	9.35	10.23	5.08	2.03	0.16	0.44	40.44	9.61	80.22	0.06	0.05	88.26	8.05	3.69
Kediri	5	A	5.0	4.5	2.19	0.22	5.90	9.86	2.20	0.80	0.22	0.43	27.16	5.96	61.24	0.19	0.04	92.67	5.21	2.12
Kediri	5	B	4.9	4.2	1.59	0.17	5.26	9.56	1.10	0.49	0.22	0.23	26.49	3.14	61.97	0.21	0.09	90.29	7.54	2.17

Table 5. Basal area in each cluster plot

No.	Location	Cluster plot	Basal area (m <sup>2</sup> )	
			1996	1999
1.	Pulau Laut	1	2214.43	2401.47
		2	749.38	1136.34
		3	608.98	698.21
		4	1374.40	1210.68
		5	1462.47	1023.53
		6	1423.19	900.85
		7	2246.92	2379.65
2.	Jambi	1	907.97	1049.18
		2	832.58	781.82
		3	-	959.29
		4	-	934.30
3.	Sumpol	8	-	843.47
		9	-	916.11
4.	Kediri	1 (5 years)	-	214.70
		2 (7 years)	-	478.52
		3 (3 years)	-	115.77
		4 (6 years)	-	336.14
		5 (4 years)	-	308.93

Remark: - data not available

### 3.2.1. Climate

Climate is considered as the dominant influence on land-use in the tropics. For practical purposes, generally climate factor affecting the plant growth is explained by means of several descriptors covering rainfall (amount and distribution), temperature, relative humidity, and intensity of solar radiation.

Rainfall data can be expressed in terms of comparison of dry month (rainfall < 60 mm per month) and wet month (rainfall > 100 mm per month). Smith and Ferguson (1951) method is to divide the average number of dry month by the average number of wet month in one year and provides rainfall type ranging from class A to class H by employing Q value. The Q value for each rainfall type is defined as follows:

A:  $0.000 \leq Q < 0.143$

B:  $0.143 \leq Q < 0.333$

C:  $0.333 \leq Q < 0.600$

D:  $0.600 \leq Q < 1.000$

E:  $1.000 \leq Q < 1.670$

F:  $1.670 \leq Q < 3.000$

G:  $3.000 < Q < 7.000$

H:  $Q > 7000$

Temperature affects the natural distribution of plant species at a given site. There are some places in the tropical areas where temperature extremes limit vegetative growth even though at high altitudes, frost may prevent the use of many tropical species (Evans, 1984). The main influence of temperature is on evapotranspiration rate in which high temperature will accelerate evaporation and therefore cause stress. Temperature of one site correlates significantly with the elevation of the site above sea level. In the tropics, areas with elevation increasing in every 100 m above sea level, results in temperature decrease of 0.3 – 0.6 °C (Webb, 1984). The correlation between air temperature changes and altitude changes of a given site is classified as follows:

Altitude (m above sea level)	Temperature (°C)
0 - 500	> 24.5
500 - 1000	22.0 - 24.5
1000 - 1500	19.5 - 22.0
1500 - 2000	17.0 - 19.5
> 2000	< 17.0

Solar radiation influences growth and development of plant through photosynthesis process. Higher radiation, when combined with a long and continuous growing season, produces very high biomass yields since more energy is available for photosynthesis. Plant requirement for solar radiation, however, varies with species and age. Some plants require low light intensity and therefore, shading is needed. Some other plants, moreover, require low light intensity during early growth and requires full light intensity at the late growth stage, and are classified as semitolerant species. In contrast, few plants require full light intensity at all time of growth stage and classified as intolerant species.

### 3.2.2. Soil

Soil fulfils three essential requirements for tree growth namely supply of nutrients, moisture, and provision of mechanical support. Critical physical and chemical characteristics of soil are applicable for land capability discussion, and among others are soil reaction (soil pH), soil texture and drainage class.

Soil pH is a good indicator for the soil fertility level since the solubility rate of most soil nutrients depends on the degree of soil reaction. In general, the availability of soil nutrients to plants is optimum when soil reaction is about neutral. In contrast, the availability of those soil nutrients decrease with soil reaction lower and higher than neutral (pH 7). For practical purposes, soil pH class is defined as follows:

- acid : pH < 6.5, neutral : pH 6.5 – 7.5, and basic : pH > 7.5

Soil texture is the relative proportion of various size groups of individual soil separates in a mass of soil and is expressed as percent of sand, silt, and clay. Soil textural class correlates with plasticity, water permeability, ease of tillage, droughtiness, fertility, and productivity of soil.

The soil physical characteristics corresponding to textural class will influence the growth and development of plant roots through the ease of exploration process of soil nutrients. Three soil textural classes will be used to assess habitat suitability, namely light texture (sandy), medium texture (loamy), and heavy texture (clayey).

Another soil textural related property is drainage class. The interrelationships between effective soil depth and available soil moisture and drainage have been reported by many scientists (Pritchett, 1979). As an inferred property, soil drainage class is indicated by characteristic profile morphology and landscape position. It indicates the extent and duration of soil saturation in years of extreme wetness as well as in normal years. Drainage control for the removal of excess water may improve soil productivity for a particular tree species and , in the long run, will also affect profound changes on stand composition and regeneration.

Soil drainage class is broken down into six classes and is summarized as follows:

Drainage class	Remarks
1. Somewhat Excessively Drained:	Water is removed very often; shallow soil, high hydrolic conductivity, internal water very rare, if occurs; very deep, coarse texture, sandy
2. Well Drained:	Water is removed rapidly, internal free water occurs very deep, no inhibition of root growth, free of redox feature
3. Moderately Well Drained:	Water is removed somewhat slowly in year, internal free water occurs moderately deep, soil wet only for short period of time, limited root inhibition
4. Somewhat Poorly Drained:	Water is removed slowly, water standing very shallow depth, water table occurs at or near the root zone, low saturated conductivity, high water table, occurs in areas with almost continuous precipitation
5. Poorly Drained:	Water is removed so slowly, remains wet for considerable long period of time, low to very low hydrolic conductivity
6. Very Poorly Drained:	Water does not move much, soil water at or above the surface, water table inhibits root growth except those tolerant, occurs on very level soil, depressed area, swamp, bog



### 3.3. Habitat Suitability

It has been pointed out by many scientists that the environmental factors that affect soil development also influence the type of plant community that develops in a particular area. More specifically, the characteristics of soil developed under a particular regime have a profound influence on the growth and development of plants. Properties such as soil texture, soil pH and nutrient status, temperature, and moisture relations are exceptionally important.

Further, as plant grows, available water and nutrients are absorbed from soils so that plant growth development process takes place in a living plant system. Within a given climatic zone, soils significantly determine the nature, productivity and spatial distribution of plant communities. In addition, by regulating water movement on the landscape, soils have also a pronounced influence on regional and local hydrology.

Based on all data collected from four study sites of forest health monitoring, the synthesis of habitat suitability is analysed to cover a wider range of various climate, and soil parameters provided. The tree species proposed is intensively examined through literature review of relevant reference as follows: 1) Andin, 1980, 2) Anonymous, 1974, 3) Anonymous, 1980, 4) Chittachumnank, 1981, 5) Dallimore and Jackson, 1966, 6) Ditjen RRL, 1995, 7) Dommergues, 1981, 8) Evans, 1982, 9) Fenton, 1977, 10) Gintings, 1989, 11) Hamzah, 1989, 12) Heyne, 1987, 13) Jacobs, 1979, 14) Letourneux, 1987, 15) Martawijaya *et al.*, 1986, 16) Martawijaya *et al.*, 1986, 17) Masano, 1995, 18) National Acad.Sci., 1979, 19) National Acad.Sci., 1980, 20) Ntima, 1968, 21) Penfold and Willis, 1961, 22) Staf Peneliti Pusat Litbang Hutan dan Konservasi Alam, 1993, 23) Streets, 1962, 24) Tham, 1979, 25) Webb *et al.*, 1984, 26) Whitmore, 1977, and 27) Wiersum and Ramlan, 1982.

The summary of proposed species and habitat suitability is presented in Table 6. It covers 49 tree species mostly grown in tropical areas with altitude ranging from 0 to 3000 meters above sea level, receive average annual rainfall which varies from 500 to 5000 mm, and with soil reaction that is mostly acidic as in the case of typical tropical soils.

## IV. CONCLUSIONS

Synthesizing the habitat suitability of forestry species can be executed by employing soil information collected from forest health monitoring activities. The forest health monitoring associated with soil indicator study was carried out in four study sites namely P.T. Inhutani II in South Kalimantan, and P.T. Asia Log in Jambi, lasting from 1996 to 1999, and P.T. Sumpol in South Kalimantan and Perum Perhutani Unit II in

Kediri, lasting in 1999. Additional information other than soil data is climate of the study sites. As many as 49 tree species mostly grown in tropical areas are proposed to be suitable to areas with altitude ranging from 0 to 3000 meters above sea level, receive average annual rainfall which varies from 500 to 5000 mm, and with soil reaction that is mostly acidic as in the case of typical tropical soils.

## ACKNOWLEDGEMENT

This Technical Report No. 22 on **Site and Species Suitability Study Based on Forest Health Monitoring Activities Conducted in South Kalimantan, Jambi and East Java** has been prepared to fulfill Objective 1 point 2.2 of the Work-plan of ITTO Project PD 16/95 Rev. 2 (F) : Forest Health Monitoring to Monitor the Sustainability of Indonesian Tropical Rain Forest.

The authors would like to thank ITTO, Ministry of Forestry (GOI), PT. INHUTANI II, PT. Asialog Forest Concession Holder, PT. SUMPOL Forest Concession Holder and Perum Perhutani Government Forest Enterprise for their support. Appreciation also goes to the Project Steering Committee members for their suggestions.

## REFERENCES

- Andin, N.A. 1980. *Acacia mangium*: A Fast growing tree for the humid tropics. Canopy International, Laguna, The Philippines.
- Anonymous. 1974. Himpunan pedoman tanaman jenis-jenis tertentu untuk reboisasi. Direktorat Reboisasi dan Rehabilitasi, Direktorat Jenderal Kehutanan.
- Anonymous. 1980. Pedoman pembuatan hutan tanaman. Direktorat Reboisasi dan Rehabilitasi, Direktorat Jenderal Kehutanan, No.15.
- Chittachumnank, P. 1981. Silviculture of *Casuarina junghuhniana* in Thailand. Paper International Casuarina Workshop, CSIRO, Canberra, Australia.
- Dallimore, W., and B. Jackson. 1966. *A Handbook of Coniferae and Ginkgoaceae*. 4 th. ed. London, Edward Arnold Ltd.
- Ditjen RRL. 1995. Hasil perumusan lokakarya penetapan species prioritas untuk reboisasi dan penanaman pohon di Indonesia. Ditjen RRL, Jakarta.
- Dommergues, Y. 1981. *Casuarina equisetifolia* in West Africa. Paper International Casuarina Workshop, CSIRO, Canberra, Australia.
- Evans, J. 1984. *Plantation forestry in the tropics*. Oxford, Clarendon Press.

- Fenton, R. 1977. Lowland tropical hardwoods: An annotated bibliography of selected species with plantation potential. Wellington, New Zealand, External Aid Div. Min. Foreign Affairs.
- Gintings, A.N. 1989. Kesesuaian tempat tumbuh berbagai jenis pohon hutan tanaman industri. Prosiding Diskusi Hutan Tanaman Industri, Badan Litbang Kehutanan, Departemen Kehutanan.
- Hamzah, Z. 1989. Kesesuaian lahan untuk penanaman jenis pohon industri. Prosiding Diskusi Hasil Penelitian Silvikultur Jenis Kayu HTI. Jakarta 15-16 Nopember 1988. Badan Penelitian dan Pengembangan Kehutanan, Jakarta.
- Heyne, K. 1987. Tumbuhan berguna Indonesia Jilid I, II, III, IV. Diterjemahkan oleh Badan Litbang Kehutanan, Jakarta.
- Jacobs, M. 1979. Eucalypts for planting. 2 nd. Ed. For. Series No. 11, Rome, FAO.
- Letourneux, C. 1987. Tree planting practices in Tropical Asia. For.Dev.Paper No. 11, Rome, FAO.
- Lutz, H.J., and R.F. Chandler Jr. 1961. Forest soils. John Wiley and Sons, Inc. London.
- Martawijaya, A., I. Kartasujana, K. Kadir dan S.A. Prawira. 1986. Atlas kayu Indonesia Jilid I. Departemen Kehutanan. Badan Litbang Kehutanan, Pusat Penelitian dan Pengembangan Hasil Hutan, Bogor.
- Martawijaya, A., I. Kartasujana, K. Kadir dan S.A. Prawira. 1986. Atlas kayu Indonesia Jilid II. Departemen Kehutanan. Badan Litbang Kehutanan, Pusat Penelitian dan Pengembangan Hasil Hutan, Bogor.
- Masano, 1995. Teknik penanaman *Khaya anthoteca*. Informasi Teknis No. 50, Pusat Litbang Hutan dan Konservasi Alam, Bogor.
- National Academy of Science. 1979. Tropical legumes. Washington, USA.
- National Academy of Science. 1980. Firewood crops. Washington, USA.
- Ntima, O.O. 1968. The Araucarias. Tropical forestry paper, No. 3. Oxford, Commonw. For. Inst.
- Penfold, A., and J. Willis. 1961. The Eucalyptus world crops. Leonard Hill, London.
- Pritchett, W.L. 1979. Properties and management of forest soils. John Wiley and Sons, Inc. New York.
- Schmidt, F.H., and J.H. Ferguson. 1951. Rainfall types based on wet and dry period ratios for Indonesia with Western New Guinea. Verh. No. 42. Direktorat Meteorologi dan Geofisika, Jakarta.
- Staf Peneliti Pusat Litbang Hutan dan Konservasi Alam. 1993. Persyaratan tempat tumbuh jenis pohon industri (*Eucalyptus urophylla*, *Duabanga moluccana*, *Acacia mangium* dan *Paraserianthes falcataria*). Pusat Litbang Hutan Bogor.
- Streets, R.J. 1962. Exotic forest trees in the British Commonw. Oxford, Clarendon Press.

- Tham, C.K. 1979. Trials of *Acacia mangium* Wild. as plantation species in Sabah. For. Genetics Res. Info. No. 9. FAO, Rome
- USDA Forest Service. 1999. Forest Health Monitoring 1999 Field Methods Guide. USDA Forest Service, National Forest Health Monitoring Program, Research Triangle Park, NC 27709.
- Webb, D.B., P.J. Wood, J.P. Smith, and G.S. Herman. 1984. A Guide to species selection for tropical and subtropical plantations. Tropical Forestry Papers No. 15. Univ.Oxford.
- Whitmore, T.C. 1977. A First look at *Agathis*. Tropical Forestry Paper No. 11, Oxford, Commonw. For.Inst.
- Wiersum, K.F., and A. Ramlan. 1982. Cultivation of *Acacia auriculiformis* on Java, Indonesia. Commonw. For. Rev. 61: 135-144.

Table 6. Proposed Species and Habitat Suitability

No	Name, Botany/Family	Name, Commercial	Growth Requirement							
			Height (m) asl	Climate/Rainfall	Air Temperature (°C)	Soil Texture	Soil pH	Drainage	Shading Tolerant	Reference
1.	<i>Acacia auriculiformis</i> A. Cunn (Leguminosae)	Acacia formis	0-500	1300-1700	20-34	Light, medium, heavy	Basic-neutral	Seasonal-water logging	Intolerant	18,30
2.	<i>Acacia mangium</i> Willd. (Leguminosae)	Mangium	0-300	1000-2100	13-32	medium	Acid-neutral	Moderately well drained	Intolerant	1,27
3.	<i>Agathis dammara</i> A. B. Lamb (Fagaceae)	Damar	100-1600	2000-4000	12-34	Light, medium, heavy	Acid-neutral	Moderately well- Somewhat poorlydrained	Intolerant	29
4.	<i>Albazia falcataria</i> (L.) Fosberg (Leguminosae)	Jeunjing	0-2000	2000-4000	20-34	Light, medium, heavy	Acid-neutral	Moderately well-Somewhat poorlydrained	Intolerant	18
5.	<i>Alstonia scholaris</i> R. Br. (Sterculiaceae)	Pulai	0-1000	A, B, C	19-33	Light, medium, heavy	Acid-neutral	Somewhat excessively-somewhat poorly drained	Semi- tolerant	15
6.	<i>Anthocephalus cadamba</i> Miq. (Rubiaceae)	Jabon	0-1000	1300-1400	19-33	Light, medium, heavy	Acid-basic	Somewhat excessively-well drained	Intolerant	28, 3, 2
7.	<i>Araucaria cunninghami</i> D. Don (Araucariaceae)	Hoop pine	0-2000	1000-1800	16-30	Medium, heavy	Acid-neutral	Well drained	Tolerant at early growth, intolerant at later	20
8.	<i>Araucaria hunsteinii</i> K. Schum (Araucariaceae)	Klinki pine	200-1800	1600-4600	12-32	Medium, heavy	Acid-neutral	Well-moderately well drained	Intolerant	5
9.	<i>Bruguiera gymnorhiza</i> L. Sav (Rhizophoraceae)	Bakau	0-50	A, B, C	29-33	Light	Acid-basic	Somewhat poorly-very poorly drained	Intolerant	16, 2
10	<i>Calliandra calothyrsus</i> Meisan (Leguminosae)	Kaliandra	150-1500	1000-3000	18-30	Light, medium, heavy	Acid-neutral	Well-somewhat poorly drained	Intolerant	8, 18

No	Name, Botany/Family	Name, Commercial	Growth Requirement							
			Height (m) asl	Climate/Rainfall	Air Temperature (°C)	Soil Texture	Soil pH	Drainage	Shading Tolerant	Reference
11	<i>Casuarina equisetifolia</i> L. (Casuarinaceae)	Cemara laut	0-1400	750-2500	10-35	Light, medium, heavy	Basic-neutral	Somewhat poorly drained	Intolerant	19, 7
12	<i>Cassia siamea</i> Lam. (Leguminosae)	Johar	0-1000	650-1500	13-35	Light, medium	Acid-neutral	Well drained	Intolerant	18, 14
13	<i>Casuarina glauca</i> Sleb. (Casuarinaceae)	Cemara	0-30	900-1150	10-30	Medium, heavy	Neutral	Somewhat poorly drained	Intolerant	19
14	<i>Casuarina junghuhniana</i> Miq. (Casuarinaceae)	Cemara gunung	0-2100	750-2000	19-28	Light, medium, heavy	Acid-basic	Well drained	Intolerant	4
15	<i>Dalbergia latifolia</i> Roxb. (Papilionaceae)	Sonokeling	0-600	C, D 1800	24-33	Light, medium, heavy	Acid-neutral	Somewhat excessively-well drained	Semi-tolerant at early growth	15, 28, 3
16	<i>Dalbergia sissoo</i> Roxb. (Papilionaceae)	Sonobrits	0-1500	500-4000	18-33	Light, medium	Acid-neutral	Somewhat excessively-somewhat poorly drained	Intolerant	28
17	<i>Diospyros celebica</i> Back. (Ebenaceae)	Eboni	0-400	1500-3500	24-33	Light, medium	Acid-basic	Somewhat excessively-well drained	Semi-tolerant	3
18	<i>Duabanga moluccana</i> Bl. (Sonnetaratiaceae)	Duabanga	30-800	B	27-32	Medium	Neutral	Somewhat excessively-well drained	Intolerant	12-24
19	<i>Dipterocarpus</i> spp. (Dipterocarpaceae)	Kruing	0-400	A, B, C	20-34	Light, medium	Acid-neutral	Well-moderately well drained	Semi-tolerant	11
20	<i>Dysoxylum</i> spp. (Meliaceae)	Garu	700-900	A, B	22-24	Light, medium	Acid-neutral	Somewhat excessively-well drained	Semi-tolerant	12
21	<i>Eucalyptus camaldulensis</i> Dehnh. (Myrtaceae)		0-1500	250-1250	10-22	Light, medium	Basic-neutral	Somewhat poorly drained	Intolerant	19, 13
22	<i>Eucalyptus deglupta</i> F. Muell. (Myrtaceae)	Leda	0-2500	2000-5000	21-32	Light, medium, heavy	Acid-neutral	Well drained	Intolerant	21

No	Name, Botany/Family	Name, Commer- cial	Growth Requirement							
			Height (m) asl	Climate/ Rainfall	Air Temperatur e (°C)	Soil Texture	Soil pH	Drainage	Shading Tolerant	Reference
23	<i>Eucalyptus pellita</i> F. Muell. (Myrtaceae)		0-1000	900-2400	12-34	Light, medium	Acid-neutral	Well drained	Tolerant	28
24	<i>Eucalyptus urophylla</i> S.T. Blake. (Myrtaceae)	Ampupu	200-3000	1100-1950	8-26	Light, medium, heavy	Acid-neutral	Well drained	Intolerant	9
25	<i>Gliricidia sepium</i> (Jacq.) Walp. (Papilionaceae)	Gamal	0-2200	500-1800	10-34	Light, medium, heavy	Acid-basic	Well-moderately well drained	Intolerant	19
26	<i>Gmelina arborea</i> Roxb. (Verbanaceae)	Gmelina	0-2100	1000-4500	18-34	Light, medium, heavy	Acid-neutral	Well-moderately well drained	Intolerant	19, 14
27	<i>Gonystylus bancanus</i> Kurz. (Thymeliaceae)	Ramin	0-100	A, B	29-33	Light, medium	Acid-neutral	Well-moderately well drained	Tolerant	15, 12, 2
28	<i>Intsia bijuga</i> O. Ktze (Caesalpiniaceae)	Merbau	0-50	A, B, C, D	29-33	Light, medium	Acid-basic	Somewhat excessively-moderately well drained	Intolerant	16, 12
29	<i>Khaya anthotheca</i> A.Juss. (Meliaceae)	Kaya	50-300	1500-2000	20-26	Medium, heavy	Acid-neutral	Somewhat excessively-moderately well drained	Intolerant	17
30	<i>Khaya senegalensis</i> (Desr.) (Meliaceae)	African mahogany	0-1800	700-1500	11-34	Medium, heavy	Acid-neutral	Moderately well drained	Tolerant at early growth	17
31	<i>Lophopetalum javanicum</i> Zoll. (Celastraceae)	Perupuk	0-50	A, B	29-33	Medium, heavy	Acid-neutral	Somewhat poorly-very poorly drained	Intolerant	12
32	<i>Manilkara kauki</i> Dubard. (Sapotaceae)	Sawo kecil	0-300	1300-1900	24-33	Medium, heavy	Neutral	Somewhat excessively-well drained	Intolerant	11
33	<i>Melaleuca leucadendron</i> (L.) Don. (Myrtaceae)	Kayu putih	0-800	800-1600	18-34	Light, medium, heavy	Acid-neutral	Moderately well drained	Intolerant	9
34	<i>Michelia champaca</i> Linn. (Magnoliaceae)	Cempaka	0-500	1000-4000	20-33	Light, medium	Neutral	Well drained	Intolerant	12

No	Name, Botany/Family	Name, Commercial	Growth Requirement							
			Height (m) asl	Climate/Rainfall	Air Temperature (°C)	Soil Texture	Soil pH	Drainage	Shading Tolerant	Reference
35	<i>Octomeles sumatrana</i> Miq., Schum. (Datisceae)	Binuang	0-500	2000-5000	20-24	Light, medium	Acid	Well-moderately well drained	Intolerant	9
36	<i>Peronema canescens</i> Jack. (Verbenaceae)	Sungkai	0-600	A, B, C	24-33	Light, medium	Acid-neutral	Somewhat excessively-moderately well drained	Intolerant	15, 28, 3
37	<i>Pinus caribea</i> Morelet. (Pinaceae)	Caribbean pine	0-1000	600-4000	15-34	Light, medium	Acid-neutral	Well-somewhat poorly drained	Intolerant	5
38	<i>Pinus merkusii</i> Jungh et de Vriese (Pinaceae)	Tusam	800-1600	2000-3000	16-30	Light, medium	Acid-neutral	Well drained	Intolerant	5, 25
39	<i>Pinus oocarpai</i> Schiede. (Pinaceae)	Ocoti pine	0-2000	750-1500	8-30	Light, medium, heavy	Acid-neutral	Well drained	Intolerant	5
40	<i>Pometia pinnata</i> Kurz. (Sapindaceae)	Matoa	0-600	A, B	24-23	Medium, heavy	Acid-basic	Somewhat excessively-well drained	Intolerant	15
41	<i>Rhizophora apiculata</i> Bl. (Rhizophoraceae)	Bakau-bakau	0-50	A, B, C	29-33	Light	Acid-basic	Somewhat poorly-very poorly drained	Intolerant	16,2
42	<i>Santalum album</i> L. (Santalaceae)	Cendana	50-800	1100-2000	22-33	Medium, heavy	Neutral-basic	Somewhat excessively-well drained	Intolerant	12, 3, 2
43	<i>Sesbania grandifolia</i> (L.). (Caesalpineaceae)	Turi	0-800	1000-2000	18-34	Light, medium, heavy	Acid	Somewhat poorly drained	Intolerant	19
44	<i>Shorea leprosula</i> Miq. (Dipterocarpaceae)	Meranti merah	0-1300	A, B, C	20-33	Medium, heavy	Acid-neutral	Somewhat excessively-moderately well drained	Tolerant at early growth	15, 12, 2
45	<i>Shorea macrophylla</i> Ash. (Dipterocarpaceae)	Meranti merah	0-500	A, B, C	29-33	Light, medium	Acid-neutral	Moderately well-somewhat poorly drained	Semi-tolerant	15



No	Name, Botany/Family	Name, Commer- cial	Growth Requirement							
			Height (m) asl	Climate/ Rainfall	Air Temperatur e (°C)	Soil Texture	Soil pH	Drainage	Shading Tolerant	Reference
46	<i>Shorea polyandra</i> Ash. (Dipterocarpaceae)	Meranti putih	0-500	A,B,C	20-33	Light, medium, heavy	Acid- neutral	Moderately well-somewhat poorly drained	Semi- tolerant	
47	<i>Swietenia macrophylla</i> King. (Meliaceae)	Mahoni	50-1400	1600-4000	11-35	Medium, heavy	Basic- neutral	Well drained	Intolerant	14
48	<i>Tectona grandis</i> L.f (Verbanaceae)	Jati	0-900	1250-3000	18-32	Medium, heavy	Basic- neutral	Well drained	Intolerant	14
49	<i>Tarrietia javanica</i> Bl. (Sterculiaceae)	Palapi	0-600	A, B, C	24-33	Medium, heavy	Acid- neutral	Well- moderately well drained	Intolerant at early growth	15

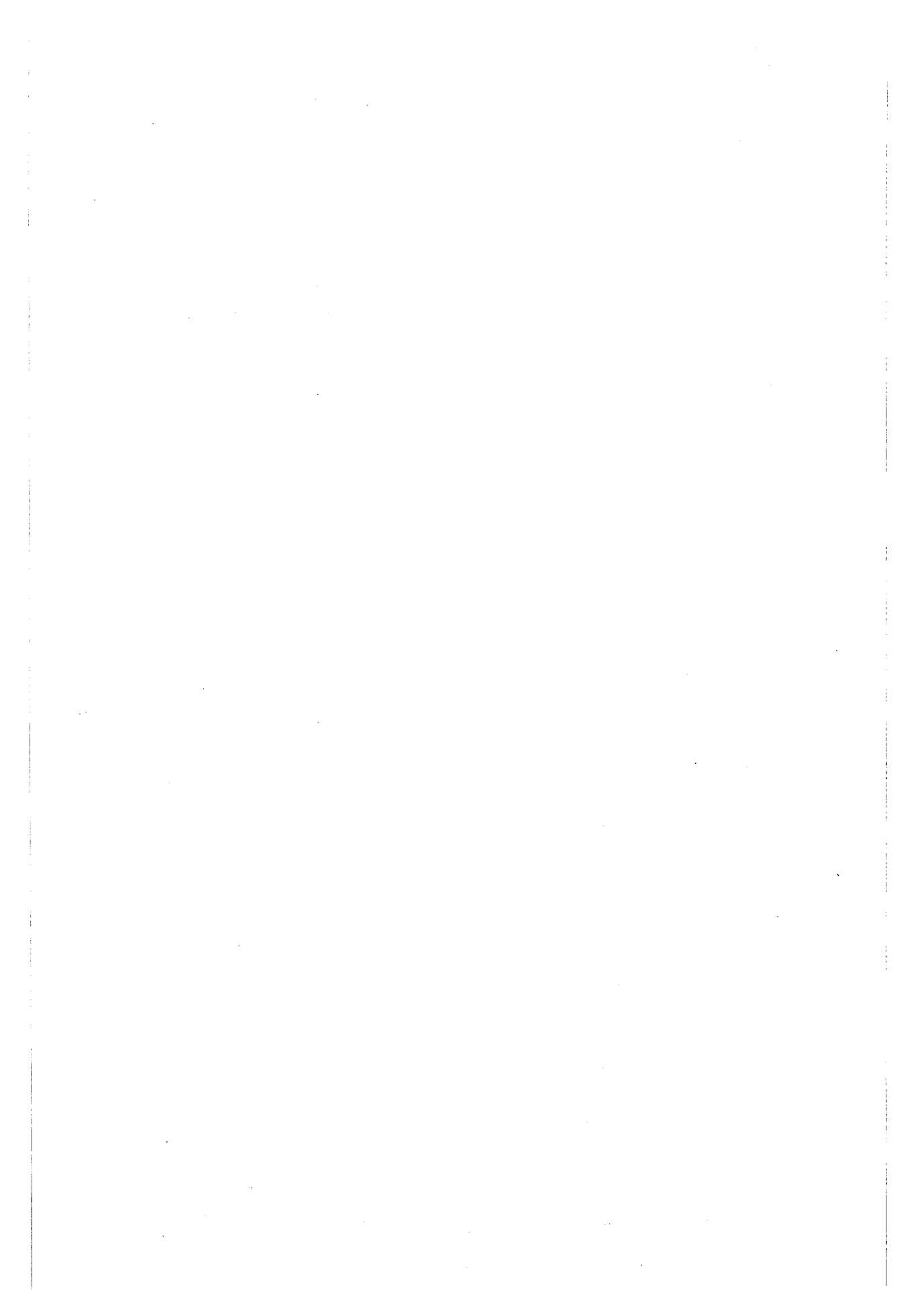

# STAND STRUCTURE (STATUS, CHANGE, TRENDS) IN FOREST HEALTH MONITORING

*Technical Report No. 23*

Supriyanto  
Ujang Susep Irawan  
Erianto Indra Putra  
I Wayan Susi Dharmawan

## ABSTRACT

A natural forest ecosystem is health if the structure of the stand represents different classes of diameter (seedling, sapling, pole and tree stages). The changes of structure can be resulted from the diameter growth over the time. While the trend of stand structure depends on the stressors influencing the growth, either natural or human induced stressors. To study the stand structure, FHM cluster plots were established in different forest stand: natural forest, secondary forest (seed production areas) and plantation forests. The FHM cluster plot model followed the Forest Health Monitoring: Field Methods Guide (International – Indonesia) issued by EPA (1997). Data was collected for 5 years. The result showed that the diameter distribution in natural and logged-over forest follows the classical inverse-J distribution, while in plantation forest follows normal curve distribution, over the period of measurement. The trees within the diameter 20 to 40 cm dominated the diameter growth of the stand either in Pulau Laut or in Jambi. The diameter growth of the trees higher than 40 cm in diameter was very slow. The ratio between saplings, poles and mother trees and mature trees was 238:179: 91: 30 in Pulau Laut, while in Jambi was 1501: 243: 170: 30, respectively. The number of mature trees (50 cm up) in Pulau Laut and Jambi shows the same trends (30 trees/ha). The trees within the diameter 20 – 29.9 cm dominated the mortality. The stand structure changes in seed production area were significantly affected by silvicultural treatment to stand (thinning). The number of seedling, sapling and pole decreased significantly, and finally tends to be dominated by the mother trees producing the seeds. The stand structure in Dipterocarps plantation (planted in 1976) is distributed from 15 – 45 cm and dominated by the diameter 25 – 30 cm. Seedling, sapling and pole from the regeneration was not found. There will be some seedlings when the trees start bearing the seeds.

**Key words :** *Stand structure, logged-over forest, sapling, pole, mother tree*

## I. INTRODUCTION

Stand structure is the distribution of number of trees per unit area (hectare) in different diameter classes (Meyer et al., 1961). Daniel et al. (1987) described that stand structure is age distribution and or diameter class distribution and canopy class distribution. Oliver and Larson (1990) stated that stand structure is temporary distribution and physical distribution of trees in certain forest area. In this report the stand structure is defined as the tree distribution per hectare in different diameter classes.

A natural forest ecosystem is health if the structure of the stand represents different classes of diameter. The changes of structure can be resulted from the diameter growth over the time. While the trend of stand structure depends on the stressors

influencing the growth, either natural or human induced stressors. The natural stressors can be affected by the light, nutrition, and space competition or mortality. The human stressors can be resulted from the stand management, such as thinning, pruning and selective lossing.

Indonesia applies the silviculture system of Indonesian Selective Cutting and Replanting System (TPTI). The minimum diameter cutting of this system is 50 cm in Dry Land Forest, and 35 cm in Peat-Swamp Forest. The sustainable forest management in TPTI system considers the diameter class distribution until the next cutting cycle (35 years). The number of small diameter is always higher than the bigger diameter class. During the implementation of TPTI system, the minimum remaining mother trees is 25 trees with the diameter distribution 20 – 50 cm. It is expected that the mother trees bear the seeds for the regeneration. The mother trees can be logged in 35 years latter. The annual allowable cutting depends on the actual diameter growth of the mother trees.

## II. MATERIALS AND METHODS

To study the stand structure, FHM cluster plots were established in different forest stands: natural forest (biodiversity conservation area), secondary forest (logged in 1978, 1994, 1995, seed production areas) and plantation forests. The FHM cluster plot model followed the Forest Health Monitoring: Field Methods Guide (International – Indonesia) issued by EPA (1997), see Figure 1.

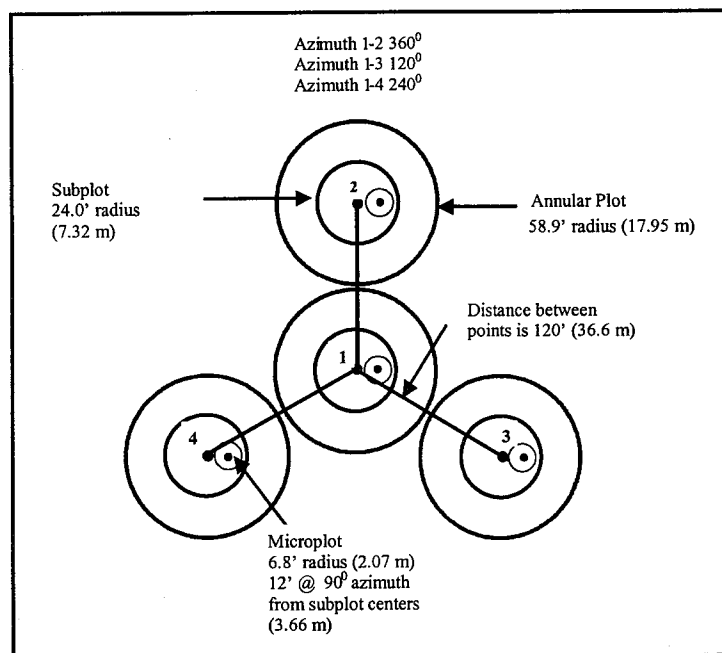

Figure 1. FHM plot layout is designed around four points (subplot centers)

The trees position were mapped using their azimuth and horizontal distance to the plot center. The diameter of trees was recorded for every year. Saplings (2.5 – 9.9 cm in diameter) were recorded in subplot. Poles (10-19.9 cm in diameter) were recorded in subplot, and the trees were recorded in annular plot. The trees diameter was classified in 10-19.9, 20-29.9, 30-39.9, 40-49.9, and 50 cm up. The status, changes and trends of vegetation structure were analyzed.

The study on stand structure in Forest Health Monitoring was focused on sapling (DBH 2.5 – 9.9 cm), poles (DBH 10 – 19.9 cm), mother trees (DBH 20 – 49.9 cm), and mature trees (DBH 50 cm up). The change of stand structure depends on the forest classification and management. The healthy of natural forest ecosystem should diverse in their stand structure. The study on stand structure was carried out in different forest conditions as follows:

1. Natural Forest: cluster plot number 2 (Pulau Laut), and number 4 (Jambi).
2. Logged-over area: cluster plots number 1 and 7 (Pulau Laut) and number 1 and 2 (Jambi).
3. Seed production area: cluster plots number 4, 5, and 6 (Pulau Laut) and number 3 (Jambi).
4. Plantation forest: cluster plots number 3 (Pulau Laut).

### III. RESULTS AND DISCUSSIONS

#### 3.1. Stand Structure in Natural Forest

FHM cluster plot 2 in Pulau Laut is located in Natural Forest. This area is used for the Biodiversity Conservation Area. The area is dominated by *Shorea polyandra* and *Dipterocarpus* sp. The diameter of some trees reaches more than 50 cm. The canopy of the forest is very dense. Canopy density blocked sunlight reaching to the forest floor. The regeneration and development of the seedlings, saplings and poles depend very much to the quantity and quality of light.

The FHM cluster plot 4 in Jambi is located in Natural Forest of mixed Dipterocarp forest. The diameter of trees reaches more than 50 cm. This natural forest is also subjected as permanent plot for the National Forest Inventory (NFI).

During three years of measurement, the number of saplings in Pulau Laut increased in the second year and decreased in the third year, but in Jambi, the number of saplings tends to decrease due to the canopy closure (Table 1). The canopy opening causes the increment of sapling in Pulau Laut. The number of trees (DBH 20 cm up) was 139 trees/ha in 1996 and became 121 trees / ha in 2000 (Table 2). The number of death trees from 1998 to 2000 was 29 trees/ha in Jambi and 18 trees in Pulau Laut during the

period of 1996 -2000. The number of death trees in Jambi was higher than in Pulau Laut. Those death trees produced a gap. The sunlight penetrates the gap and goes to the forest floor to stimulate the diameter growth. The changes and trends of sapling structure in natural forest are mostly affected by the dynamic of canopy closure of the dominant trees and tree density.

Table 1. Status, Change and Trends of Sapling in Natural Forest at Pulau Laut and Jambi

Forest Function	Cluster Plot	Year		
		1998	1999	2000
Natural Forest, Pulau Laut	2.1.PUL	3	7	4
	2.2.PUL	1	4	4
	2.3.PUL	7	8	8
	2.4.PUL	0	3	0
	Total	11	22	16
	Average	2.75	5.5	4
	<b>N/ ha</b>	<b>164</b>	<b>327</b>	<b>238</b>
Natural Forest, Jambi	4.1.JAM	10	11	8
	4.2.JAM	43	41	42
	4.3.JAM	17	15	16
	4.4.JAM	34	33	35
	Total	104	100	101
	Average	26	25	25.25
	<b>N/ ha</b>	<b>1545</b>	<b>1486</b>	<b>1501</b>

Table 2. DBH Distribution in Natural Forest on Cluster Plot 2 at Pulau Laut and Cluster Plot 4 at Jambi

DBH Class (cm)	Year				
	1996	1997	1998	1999	2000
<b>Cluster Plot 2, Pulau Laut.</b>					
2.5-9.9	-	-	164	327	238
10-19.9	298	298	224	209	179
20-29.9	73	73	63	60	50
30-39.9	45	45	40	40	23
40-49.9	35	33	28	28	18
50-59.9	13	15	20	20	20
60 up	13	13	13	13	10

Table 2. (Continuation)

Cluster Plot 4, Jambi*					
2.5-9.9			1545	1486	1501
10-19.9	-	-	387	343	343
20-29.9	-	-	110	98	100
30-39.9	-	-	55	58	55
40-49.9	-	-	23	15	15
50-59.9	-	-	8	13	10
60 up	-	-	23	20	20

\*: FHM cluster plot number 4 was established in 1998

Table 2 shows that the number of sapling in Pulau Laut and Jambi was affected by the ingrowth of seedlings, while the number of poles and trees was affected by mortality rate. The number of mother trees in Pulau Laut and Jambi was 91 and 170 trees.

The ratio between saplings, poles and mother trees and mature trees was 238:179: 91: 30 in Pulau Laut, while in Jambi was 1501: 243: 170: 30, respectively. Mortality rate in sapling to pole is very high. The number of poles in both areas is limited. It is possible that during the previous year the diameter growth of poles was very rapid. It can be proved in their number of mother trees that is higher than the number of poles. The number of mature trees (50 cm up) in Pulau Laut and Jambi shows the same trends (30 trees/ha). It can be concluded that the mother trees dominate the stand structure of natural forest in Jambi and Pulau Laut.

### 3.2. Stand Structure in Logged-over Forest

Stand structure in logged over areas was studied in cluster plot number 1 and 7 (logged in 1978) at Pulau Laut and cluster number 1 and 2 (logged in 1995) at Jambi.

FHM cluster plot in Pulau Laut was established 20 years after logging activities, while in Jambi cluster plot was established in the same year of logging. The area was logged using the silviculture system of Indonesian Selective Cutting and Replanting System.

The number of sapling in Jambi is higher than in Pulau Laut. It means that the number of sapling three years after logging is still very high, but twenty years after logging the number of sapling decrease significantly and closed to the natural forest conditions (Table 3). The number of sapling in Pulau Laut tends to decrease, while in Jambi the number of sapling tends to increase. It is possible that twenty years after logging the canopy closure of the stand become very high, or very low canopy opening. While 3 years after logging, the canopy opening became very high. It can be concluded that

canopy opening stimulate the diameter growth of sapling, meanwhile the canopy closure increase the mortality of saplings. The number of sapling in Pulau Laut was 164 – 253 saplings/ha and 1739 – 2140 saplings/ha in Jambi.

Table 3. Status, Change and Trends of Sapling in Logged-Over Forest at Pulau Laut and Jambi (1998-2000)

Forest Classification	Cluster/ Plot	Year		
		1998	1999	2000
Logged-over Forest, Pulau Laut, Logged in 1978.	1.1 PUL	1	1	0
	1.2.PUL	8	7	7
	1.3.PUL	6	6	2
	1.4.PUL	2	2	2
	Total	17	16	11
	Average	4.25	4	2.75
	<b>N/ ha</b>	<b>253</b>	<b>238</b>	<b>164</b>
Logged-over Forest, Pulau Laut, logged in 1978.	7.1 PUL	17	16	10
	7.2.PUL	5	4	2
	7.3.PUL	17	17	2
	7.4.PUL	8	8	3
	<b>Total</b>	<b>47</b>	<b>45</b>	<b>17</b>
	Average	11.75	11.25	4.25
	<b>N/ ha</b>	<b>698</b>	<b>669</b>	<b>253</b>
Logged-over Forest, Jambi, logged in 1995.	1.1 JAM	40	39	45
	1.2.JAM	43	35	36
	1.3.JAM	14	14	22
	1.4.JAM	34	34	41
	Total	131	122	144
	Average	32.75	30.5	36
	<b>N/ ha</b>	<b>1947</b>	<b>1813</b>	<b>2140</b>
Logged-over Forest, Jambi, logged in 1995.	2.1 JAM	11	13	21
	2.2.JAM	35	34	34
	2.3.JAM	7	23	25
	2.4.JAM	32	37	37
	Total	85	107	117
	Average	21.25	26.75	29.25
	<b>N/ha</b>	<b>1263</b>	<b>1590</b>	<b>1739</b>

The structure of poles and trees in logged-over areas at Pulau Laut and Jambi is shown in Table 4. The number of trees in both areas during the period of measurement decreased significantly. The trees within the diameter 20 – 29.9 cm, dominate the mortality. Mortality rate of saplings to poles was very high. It can be seen in cluster plot number 1 at Pulau Laut.



Table 4. Diameter Distribution on Cluster Plot 1 and 7 at Pulau Laut (Logged in 1978) and Cluster Plot 1 and 2 at Jambi (logged in 1995)

DBH Class (cm)	Year				
	1996	1997	1998	1999	2000
<b>Cluster Plot 1, Pulau Laut, Logged in 1978</b>					
2.5-9.9			253	238	164
10-19.9	60	45	45	45	15
20-29.9	55	55	53	53	30
30-39.9	18	15	18	18	18
40-49.9	20	18	18	18	10
50-59.9	18	15	15	10	8
60 up	35	38	38	43	28
<b>Cluster Plot 7, Pulau Laut, Logged in 1978</b>					
2.5-9.9	*	*	698	669	253
10-19.9	119	89	89	89	60
20-29.9	50	53	53	58	30
30-39.9	30	28	25	28	15
40-49.9	18	20	23	23	15
50-59.9	25	20	15	13	10
60 up	50	55	58	60	28
<b>Cluster Plot 1 Jambi, Logged in 1995</b>					
2.5-9.9	*	*	1947	1813	2140
10-19.9	432	*	358	283	268
20-29.9	88	*	63	68	70
30-39.9	55	*	43	38	38
40-49.9	18	*	20	23	20
50-59.9	18	*	13	13	13
60 up	20	*	23	20	18
<b>Cluster Plot 2, Jambi, Logged in 1995</b>					
2.5-9.9	*	*	1263	1590	1739
10-19.9	462	*	417	432	387
20-29.9	80	*	73	93	90
30-39.9	45	*	48	45	45
40-49.9	40	*	35	33	35
50-59.9	10	*	8	8	8
60 up	13	*	8	8	8

\* : Data on diameter was not recorded

The stand structure in Cluster-plot 1 Pulau Laut was 164 saplings, 15 poles, 48 mother trees and 36 mature trees, while in Cluster-plot 7 Pulau Laut was 253 saplings, 60 poles, 60 mother trees and 38 mature trees. It means that 22 years after logging, the

stand structure became normal, and the number of mother trees and mature trees is quite sufficient for the next regeneration and cutting cycle. If the diameter growth of the stand is 1 cm / year, it means in the next cutting cycle (35 years after logging), the diameter of mother trees (25 trees per hectare) should be 55 – 85 cm. But now, the number of mother trees reaches 36 and 38 trees per hectare in Pulau Laut in 22 years after logging. It is possible that the number of mature trees will increase until 46 and 52 trees per hectare in the year 2013.

In Jambi the number of mothers trees in still follow the regulation of Indonesia selective cutting and replanting system. The request of mother trees in this system is 25 trees/ ha with the diameter 20 – 49,9 cm. In the plot we still found the trees with the diameter over than 50 cm, namely 31 and 16 trees / ha. It is predicted that the number of mature trees in the year 2020 will increase more than 50 trees / ha if the mortality rate is 10 %.

### 3.3. Stand Structure in Seed Production Area

Stand structure in seed production area will be different due to the management decision of the area. In most cases, the sapling of undesired trees will be cut to promote the growth of desired species.

Table 5. Status, Change and Trends of Saplings in Seed Production Area at Pulau Laut and Jambi (1998-2000)

Forest Function	Cluster Plot	Year		
		1998	1999	2000
Seed Production Area, Pulau Laut	4.1 PUL	0	0	0
	4.2.PUL	0	0	0
	4.3.PUL	0	0	0
	4.4.PUL	3	0	0
	<b>Total</b>	<b>3</b>	<b>0</b>	<b>0</b>
	<b>Average</b>	<b>0.75</b>	<b>0</b>	<b>0</b>
	<b>N/ ha</b>	<b>45</b>	<b>0</b>	<b>0</b>
Seed Production Area, Pulau Laut	5.1 PUL	3	3	2
	5.2.PUL	4	2	0
	5.3.PUL	0	0	0
	5.4.PUL	1	0	0
	<b>Total</b>	<b>8</b>	<b>5</b>	<b>2</b>
	<b>Average</b>	<b>2</b>	<b>1.25</b>	<b>0.5</b>
	<b>N/ ha</b>	<b>119</b>	<b>74</b>	<b>30</b>

Table 5. (Continuation)

Forest Function	Cluster Plot	Year		
		1998	1999	2000
Seed Production Area, Pulau Laut	6.1 PUL	3	0	1
	6.2.PUL	9	12	9
	6.3.PUL	3	1	0
	6.4.PUL	1	0	0
	<b>Total</b>	<b>16</b>	<b>13</b>	<b>10</b>
	<b>Average</b>	<b>4</b>	<b>3.25</b>	<b>2.5</b>
	<b>N/ ha</b>	<b>238</b>	<b>193</b>	<b>149</b>
Seed Production Area, Jambi	3.1 JAM	40	43	41
	3.2.JAM	47	47	45
	3.3.JAM	29	18	25
	3.4.JAM	35	37	44
	<b>Total</b>	<b>151</b>	<b>145</b>	<b>155</b>
	<b>Average</b>	<b>37.75</b>	<b>36.25</b>	<b>38.75</b>
	<b>N/ ha</b>	<b>2244</b>	<b>2155</b>	<b>2303</b>

Table 5 shows that the number of sapling in cluster-plot in Pulau Laut was very low, while in Jambi was quite high. It means that the desired species in sapling stage in Jambi was better than in Pulau Laut. The number of seedlings and saplings will increase when the trees bearing the seeds. During three years of monitoring in Pulau Laut, we didn't find a number of seedling and sapling. It is also possible that trees in this plot didn't produce the seed for quite long time. Some trees was also cut due to illegal logging.

Table 6 shows that the number of mother trees in Pulau Laut decreased significantly due to illegal logging. If the trend of illegal logging continue, it is predicted that the seed production area in Pulau Laut will not produce any seeds. It means the seed supply will stop completely. The management decision should be directed to conduct replanting system with desired species, while the management decision in Jambi should maintain the number of mother trees (20 – 49.9 cm) which is still in good number (91 trees / ha).

Table 6. DBH Distribution on Cluster 4,5, 6 at Pulau Laut and 3 at Jambi (Seed Production Area)

DBH Class (cm)	Year				
	1996	1997	1998	1999	2000
<b>Cluster Plot 4, Pulau Laut ,SPA</b>					
2.5-9.9	*	*	45	0	0
10-19.9	164	75	75	30	0
20-29.9	65	55	40	23	10
30-39.9	60	50	28	10	5
40-49.9	40	38	38	13	3
50-59.9	18	15	10	8	3
60 up	25	13	8	3	0
<b>Cluster Plot 5, Pulau Laut , SPA</b>					
2.5-9.9	*	*	119	74	30
10-19.9	268	149	134	89	149
20-29.9	73	60	35	10	5
30-39.9	45	40	20	8	3
40-49.9	30	20	13	5	3
50-59.9	8	5	5	5	5
60 up	40	25	15	3	3
<b>Cluster Plot 6, Pulau Laut , SPA</b>					
2.5-9.9	*	*	238	193	149
10-19.9	283	194	179	75	45
20-29.9	88	83	63	45	33
30-39.9	48	50	55	38	35
40-49.9	18	23	25	5	5
50-59.9	15	15	15	5	5
60 up	35	30	25	8	0

Table 6. (continuation)

DBH Class (cm)	Year				
	1996	1997	1998	1999	2000
<b>Cluster Plot 3, Jambi, SPA</b>					
2.5-9.9	+	*	2244	2155	2303
10-19.9	+	417	343	283	343
20-29.9	+	73	55	48	43
30-39.9	+	45	30	30	30
40-49.9	+	25	15	15	18
50-59.9	+	5	3	3	3
60 up	+	20	13	13	13

\* : Data on diameter was not recorded

+: Cluster plot 3 Jambi was established in 1997

### 3.4. Stand Structure in Plantation Forest

Plantation of *Shorea polyandra* in Pulau Laut was established in 1976. Until the period of FHM plot establishment (22 years), there was no thinning treatment. The seedling was planted in spacing distance of 5 X 5 m. Until 1998, the trees did not produce any seeds. It means during 22 years, *Shorea polyandra* did not produce seed. As consequences, we did not find any seedling during the period of monitoring (1998 – 2000).

Table 7. Status, Change and Trends of Saplings in *Shorea polyandra* Plantation at Pulau Laut

Forest Classification	Cluster Plot	Year		
		1998	1999	2000
Plantation Forest	3.1 PUL	0	0	0
	3.2.PUL	0	0	0
	3.3.PUL	0	0	0
	3.4.PUL	0	0	0
	<b>Total</b>	<b>0</b>	<b>0</b>	<b>0</b>
	<b>Average</b>	<b>0</b>	<b>0</b>	<b>0</b>
	<b>N/ ha</b>	<b>0</b>	<b>0</b>	<b>0</b>

Table 8 shows the diameter distribution of *S. ployandra* of 22 years old. Some trees reached the diameter 40 – 50 cm, but mostly the diameter of the trees was distributed in 10 – 20 cm (119 trees) and 80 tress in diameter 20 – 40 cm. It means the diameter growth of *S. polyandra* plantation could reach more than 1 cm/ year in average.

The management decision of the plantation is to conduct a thinning for the trees in diameter of 10 – 20 cm to stimulate the growth of trees distributed in diameter of 20 – 40 cm.

Table 8. DBH Distribution on Cluster 3, Pulau Laut

DBH Class (cm)	Year				
	1996	1997 *	1998	1999	2000
2.5-9.9	*	*	0	0	0
10-19.9	134	*	134	134	119
20-29.9	45	*	45	45	45
30-39.9	35	*	35	35	35
40-49.9	5	*	5	5	5
50-59.9	0	*	0	0	0
60 up	0	*	0	0	0
<b>TOTAL</b>	<b>219</b>		<b>219</b>	<b>219</b>	<b>204</b>

\* : data on DBH was not recorded

#### IV. CONCLUSIONS

Stand structure is a good indicator in Forest Health Monitoring toward sustainable forest management in natural forest. Forest is healthy if their structure consists of seedlings, saplings, poles, and trees in sufficient number.

#### ACKNOWLEDGEMENT

This Technical Report No. 23 on the **Stand Structure (Status, Change and Trends)** has been prepared to fulfill Objective 1 point 2.2 of the Work-plan of ITTO Project PD 16/95 Rev. 2 (F): Forest Health Monitoring to Monitor the Sustainability of Indonesian Tropical Rain Forest.

The authors would like to thank ITTO, Ministry of Forestry (GOI), PT. INHUTANI II, and PT. Asialog Concession for their support. Appreciation also goes to the Project Steering Committee members for their suggestions.

## REFERENCES

- Daniel, T.W., J.A. Helm S. and F.S. Baker, (1987). Principle of Silviculture. Second Edition.
- Mayer, H.A., A.B. Recknagel, D.D. Stevenson, and R.A. Bartoo. (1961), Forest Management. The Ronald Press Co., New York.
- Oliver, C.D., and B.C. Larson. (1990). Forest Stand Dynamic. Biol. Res. Management Series. McGraw- Hill, New York.

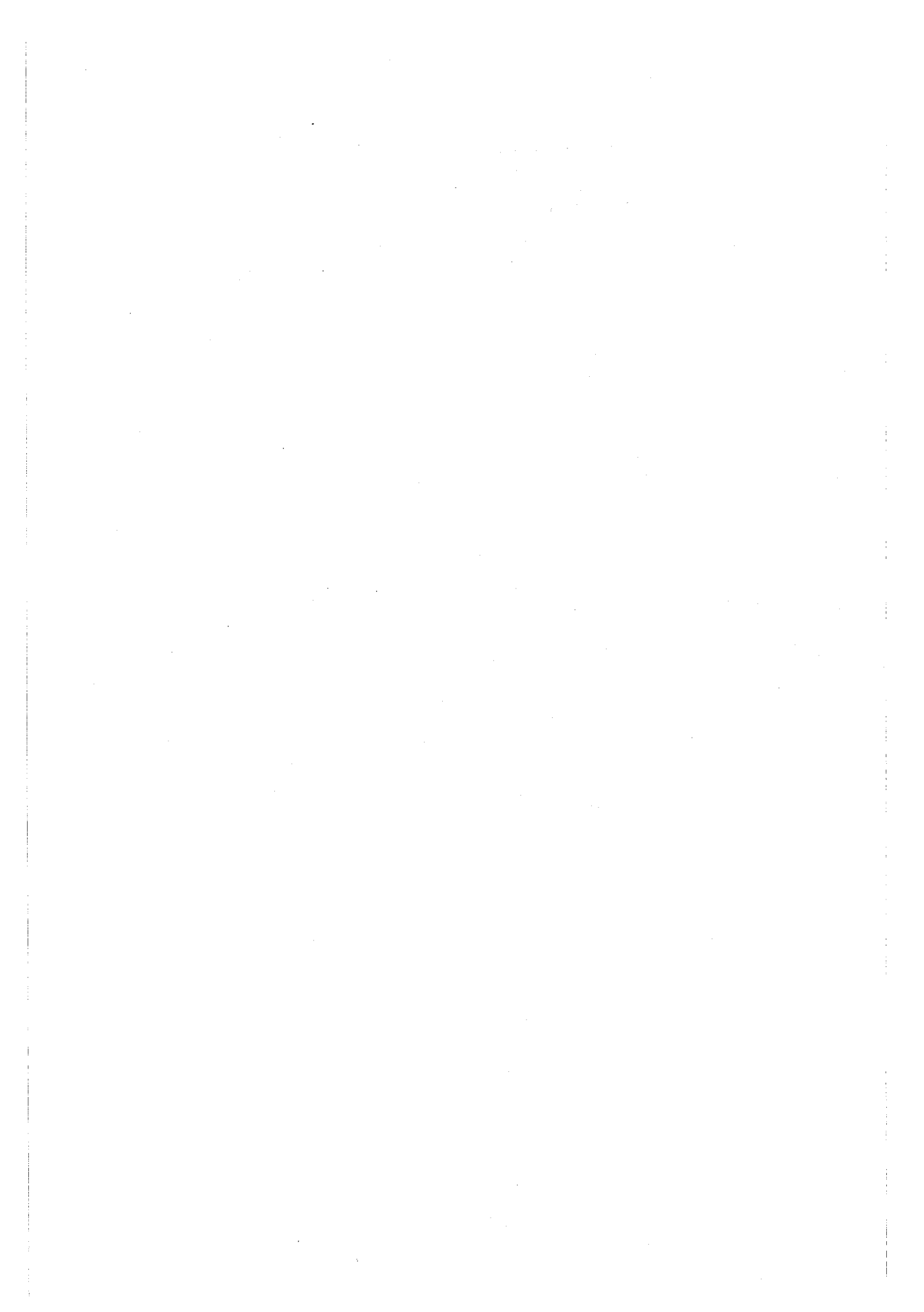



# REGENERATION AND MORTALITY

*Technical Report No. 24*

Supriyanto  
Ujang S. Irawan  
I Wayan S. Dharmawan  
Erianto I. Putra

## ABSTRACT

One group of criteria to be addressed in INDO-FHM is environmental criteria, which will address biodiversity composition, abundance, habitat suitability and ecosystem processes (growth, regeneration, mortality, stand structure) and productivity. Regeneration and mortality plays important role in the sustainable forest management, especially in uneven age natural forest. Regeneration and mortality were measured in INDO-FHM plots in Pulau Laut and Jambi. The number of mature trees (50 cm up) in Pulau Laut and Jambi shows the same trends (12 trees/ha). The trees within the diameter 20 – 29.9 cm dominated the mortality. The mortality rate in Pulau Laut was 35 % - 63.7 % (Saplings) 19.29 % (poles), 8.21 % (trees). The mortality rate in Jambi was 0.9 % - 2.8 % (Sapling), 20.49 % (poles) and 19.28 % (trees). The mortality rate due to fire was 100 % (seedlings), 50 % - 100 % (saplings) 27.06 % (poles), 37.18 % (trees). The mortality of sapling, poles and trees in Dipterocarps plantation was not found during the period of measurement.

**Key words** : *Regeneration, mortality, natural forest, sustainable forest management*

## I. INTRODUCTION

One group of criteria to be addressed in INDO-FHM is environmental criteria, which will address biodiversity composition, abundance, habitat suitability and ecosystem processes (growth, regeneration, mortality, stand structure) and productivity. Regeneration and mortality plays important role in the sustainable forest management, especially in uneven age natural forest.

Regeneration and mortality is part of forest ecosystem dynamic. Forest dynamic depend on the environmental stressors received by the stand in time. Seedlings and saplings are the structure that very sensitive to the light intensity, especially light demander species (Lamprect, 1989). Canopy density and opening affect very much to the light intensity received by the forest floor. The dynamic of pole and trees is mostly due to the stand density and damage, both due to biotic or abiotic causal agents. Insects, diseases, could cause the biotic damage. The abiotic damage could also cause by fire and logging.

Silvicultural system of Indonesian Selective Cutting and Replanting System was applied in natural forest since 1972. The system was renewed in 1989. The structure of residual stand should minimal consist of 25 mother trees/ha, 75 poles/ha, 200 saplings/ha and 400 seedlings/ha of commercial species (MOF, 1989). Regeneration and mortality of residual stand will affect the stand structure. The enrichment planting must be done

when the number of commercial trees is not sufficient. Hamzah (1978) reported that the mortality rate of seedling could achieve 60 % of total seedlings in two years after their germination.

## II. MATERIALS AND METHODS

INDO-FHM plots were established in Pulau Laut at Natural Forest (Buffer Zone Area, Biodiversity Conservation Area, Seed Production Area, and Plantation Area) and in Jambi (Natural Forest Area, and Seed Production Area). Plot establishment followed the Forest Health Monitoring: Field Methods Guide (International – Indonesia), issued by USDA Forest Service, 1997. One cluster plots consists of 4 annular plots, 4 sub-plots, and 4 micro plots (Figure 1). Trees, poles and seedlings were recorded in annular plots, sub-plots, and micro plots. Saplings were also recorded in sub – plots. The number of trees, poles, saplings, and seedlings per hectare was used for the basic analysis of regeneration or mortality over the period of observation. Trees and poles were observed during 5 years, while sapling and seedlings were observed for three years.

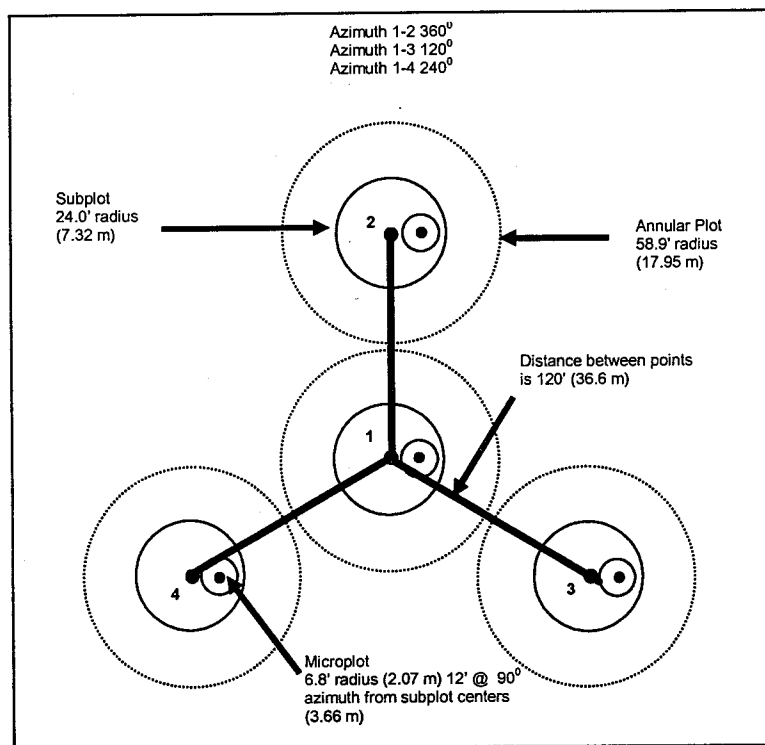

Figure 1. FHM Cluster-plot Design

### III. RESULTS AND DISCUSSIONS

#### 3.1. Regeneration

The capability of forest to recover their condition after logging can be seen from their regeneration status. Mortality could happen due to the environmental stressors or human activity (thinning and logging). Table 1 showed that the regeneration capability in sapling stage was different among plot locations. The mortality rate in Pulau Laut was caused by forest fire, while in Jambi due to natural stressors.

Natural forest in Pulau Laut (Cluster plot 1, 2, and 7) is dominated by *Shorea polyandra*. The ratio of sapling : poles : mother trees : mature trees in natural forest was 238 : 12 : 36 : 12 (see Technical Report No. 14). There was an ingrowth from seedlings to sapling in cluster plot 1 amounting to 45 %, due to the number of favorable environmental conditions for example canopy opening. In this stage the saplings become light demanding, while in cluster plot 2 and 3 there was sapling mortality ranging from 2.8 % to 35 % due to illegal logging. Most of the sapling severed from logging damage for example broken stem and branches. The mortality rate of saplings in seed production area (cluster plot 4, 5, and 6) was very high ranging from 50 % to 100 % due to forest fire. Cluster plot number 4, 5, and 6 was dominated by *Dipterocarpus* sp.

Table 1. Regeneration and mortality of saplings in Pulau Laut and Jambi

Location	Cluster Plot	1998 (N/Ha)	2000 (N/Ha)	Regeneration (+) / Mortality (-)
<b>Pulau Laut</b>				
Natural Forest	1	164	238	+ 45 %
Natural Forest	2	253	164	- 2.8 %
Dipterocarps Plantation	3	0	0	0 %*
Seed Prod. Area	4	45	0	- 100 %*
Seed Prod. Area	5	119	30	- 74.8 %*
Seed Prod. Area	6	238	119	- 50 %*
Natural Forest	7	698	253	- 35 %
<b>Jambi</b>				
Natural Forest	1	1947	2140	- 0.9 %
Natural Forest	2	1263	1739	+ 37 %
Seed Prod. area	3	2244	2303	+ 2.6 %
Natural Forest	4	1545	1501	- 2.8 %

Note: \* Mortality due to forest fire in year 1997

The regeneration rate in FHM cluster plot in Jambi (Cluster plot 2 and 3) was 2.6 % to 37 %, while the mortality rate was 0.9 % to 2.8 %. The ratio of saplings, poles, mother trees, and mature trees in natural forest was 1501 : 23 : 68 : 12 (see Technical Report No. 14). The mortality rate of sapling in Jambi was lower than in Pulau Laut. The species composition in Jambi was a mixed – *Dipterocarps* forest. The regeneration of

sapling in Jambi due to seedling ingrowth, meanwhile the mortality rate in Jambi was caused by canopy closure. It is conclusive that forest fire in the most dangerous natural disaster that affected very much to the sapling mortality.

### 3.2. Mortality Rate

#### 3.2.1. Pulau Laut

Table 2 showed that the mortality rate in the logged forest (in 1978) was 8.47% and 1.33% for trees, while for poles was 25% and 12.5% (cluster plot 1 and 7). The mortality rate in Natural Forest (Cluster-plot 2) was 14.86% for trees and 20 % for poles (cluster plot 2). In this case, the death trees produced a gap that will promote the regeneration or ingrowth. The mortality rate in Plantation Forest was 0% during 4 years observation because we didn't find any seedlings or saplings in the plots (cluster plot 3).

Table 2. The mortality rate of poles and trees in Pulau Laut during 4 years observation

Cluster	Plot	Trees			Poles		
		N	M	% M	N	M	%M
1 (logged in 1978)	1	15	0	0.00	2	0	0.0
	2	13	1	7.69	0	0	0.0
	3	17	3	17.65	2	1	50.0
	4	14	1	7.14	0	0	0.0
	Total	59	5	33.88	4	1	50.0
	Avg	14.75	1.25	8.47	2	0.5	25.0
2 (natural forest)	1	23	1	4.35	4	0	0
	2	17	1	5.88	7	1	14.3
	3	19	6	31.58	4	1	25.0
	4	15	3	20.00	5	2	40.0
	Total	74	11	59.44	20	4	79.0
	Avg	18.50	2.75	14.86	5.0	1.0	20.0
7 (logged in 1978)	1	19	1	5.26	1	0	0.0
	2	21	0	0.00	4	0	0.0
	3	15	0	0.00	2	0	0.0
	4	20	0	0.00	1	1	100.0
	Total	75	1	5.26	8	1	100.0
	Avg	18.75	0.25	1.33	2.00	0.25	12.5
<b>Average Natural Forest</b>				<b>8.21</b>			<b>19.29</b>
3 (plant. forest)	1	10	0	0.00	1	0	0.0
	2	10	0	0.00	2	0	0.0
	3	5	0	0.00	2	0	0.0
	4	11	0	0.00	4	0	0.0
	Total	36	0	0.00	9	0	0.0
	Avg	9	0.00	0.00	2.25	0.00	0.00

The mortality rate of poles and trees in natural forest and logged – forest in 1978 was quite high, due to illegal logging, but in plantation forest was 0 %. In plantation forest, the stand was dominated by *Shorea polyandra* that was planted in 1976 and no thinning was conducted during the period of 1976 to 2000. It is important to be notice that illegal logging affected the sustainability of forest in term of production.

### 3.2.2. Jambi

Table 3 showed that the mortality rate in FHM Cluster-plot in Jambi varied among the plots.

Table 3. The mortality rate of poles and trees in Jambi

Cluster	Plot	Trees			Poles		
		N	M	% M	N	M	%M
1 (Natural Forest)	1	21	2	9.52	4	1	25.00
	2	13	8	61.54	10	5	50.00
	3	21	5	23.81	9	3	33.33
	4	24	1	4.17	8	2	25.00
	Total	79	16	99.04	31	11	133.33
	Avg	19.75	4.0	24.76	7.75	2.75	33.33
2 (Natural Forest)	1	20	2	10.00	8	0	0.00
	2	16	0	0.00	4	0	0.00
	3	17	4	23.53	12	1	8.33
	4	22	4	18.18	7	1	14.29
	Total	75	10	51.71	31	2	22.62
	Avg	18.75	2.50	12.93	7.75	0.50	5.66
3 (Seed Production Area)	1	17	5	29.41	6	0	0.00
	2	14	2	14.29	4	3	75.00
	3	13	7	53.85	9	4	44.44
	4	24	10	41.67	10	3	30.00
	Total	68	24	139.22	29	10	149.44
	Avg	17.00	6.00	34.81	7.25	2.50	37.36
4 (Seed Production Area)	1	27	2	7.41	5	0	0.00
	2	16	3	18.75	10	0	0.00
	3	21	1	4.76	2	0	0.00
	4	21	1	4.76	9	2	22.22
	Total	85	7	35.68	26	2	22.22
	Avg	21.25	1.75	8.92	6.50	0.50	5.56

The higher mortality rate for poles and trees was found in cluster plot 3, 37.76 % and 34.81 % respectively. Cluster plot 3 was located in seed production area, these mortality rate due to the natural stressors (thunder). The mortality rate in cluster 4 was 22.2 % in subplot number 4, due to natural death. It can be concluded that the mortality rate in Jambi was caused by natural death or stressors.

### 3.3. Mortality Rate due to fire in 1997 at Pulau Laut

Table 4 showed that mean mortality rate due to forest fire was 37.18% for trees and 27.06% for poles.

The mortality rate for poles in cluster plot 4, 5, and 6 was 17.86 %, 37.5 %, and 25.83 % respectively, while the mortality rate for trees in cluster plot 4,5, and 6 was 43.53 %, 54.43 %, and 13.58 % respectively. Those mortality was caused by forest fire that was recorded in 1998.

Table 4. Mortality Rate due to forest fire in Seed Production Area, Pulau Laut

Cluster	Plot	Due to Fire (1997), Recorded 1998					
		Trees			Poles		
		N	M	% M	N	M	%M
4	1	25	9	36.00	1	0	0.00
	2	20	10	50.00	3	0	0.00
	3	27	12	44.44	0	0	0.00
	4	13	6	46.15	7	5	71.43
	Total	85	37	174.12	11	5	71.43
	Avg	21.25	9.25	43.53	2.75	1.25	17.86
5	1	17	8	47.06	4	1	25.00
	2	20	4	20.00	4	0	0.00
	3	19	17	89.47	5	5	100.0
	4	23	14	60.87	4	1	25.00
	Total	79	43	217.72	17	7	150.0
	Avg	19.75	10.75	54.43	4.25	1.75	37.5
6	1	28	1	3.57	3	1	33.33
	2	14	4	28.57	5	1	20.00
	3	19	1	5.26	6	0	0.00
	4	20	5	25.00	6	3	50.00
	Total	81	11	54.32	20	10	103.33
	Avg	20.25	2.75	13.58	5.00	2.50	25.83
<b>Average in Seed Production Area</b>				<b>37.18 %</b>			<b>27.06 %</b>

If we compare the mortality rate among the plots, it can be concluded that the mortality due to forest fire was bigger than due to natural mortality.

The diameter distribution trees found in the FHM plot at P. Laut and Jambi is shown in Figure 2 – 12.

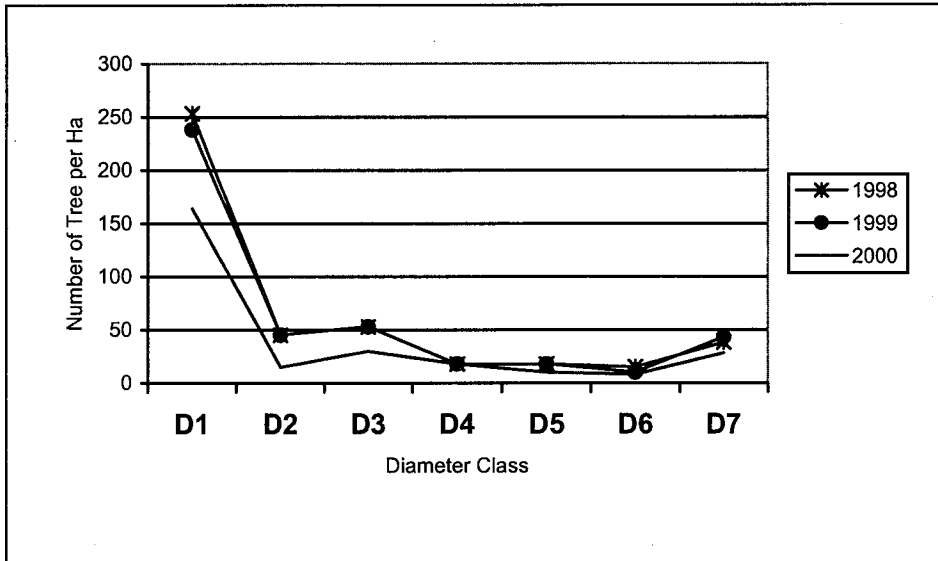

Figure 2. Diameter distribution at natural forest logged in 1978 (Cluster 1), Pulau Laut  
 Notes: D1 = 10 cm – 19.9 cm; D2 = 20 cm – 29.9 cm; D3 = 30 cm – 39.9 cm;  
 D4 = 40 cm – 49.9 cm; D5 = 50 cm – 59.9 cm; D6 = 60 cm – 69.9 cm;  
 D7 = > 70 cm

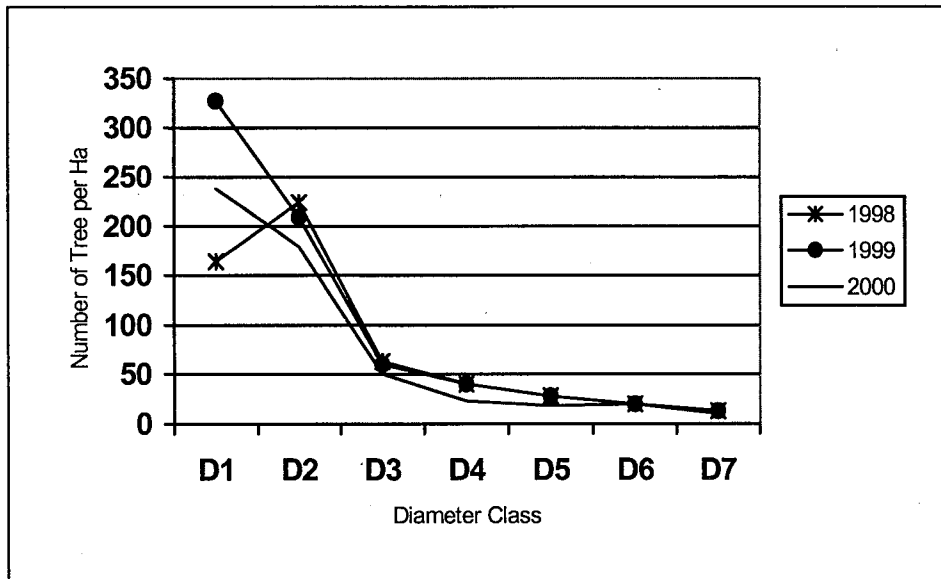

Figure 3. Diameter distribution at natural forest logged in 1978 (Cluster 2), Pulau Laut  
 Notes: D1 = 10 cm – 19.9 cm; D2 = 20 cm – 29.9 cm; D3 = 30 cm – 39.9 cm;  
 D4 = 40 cm – 49.9 cm; D5 = 50 cm – 59.9 cm; D6 = 60 cm – 69.9 cm;  
 D7 = > 70 cm

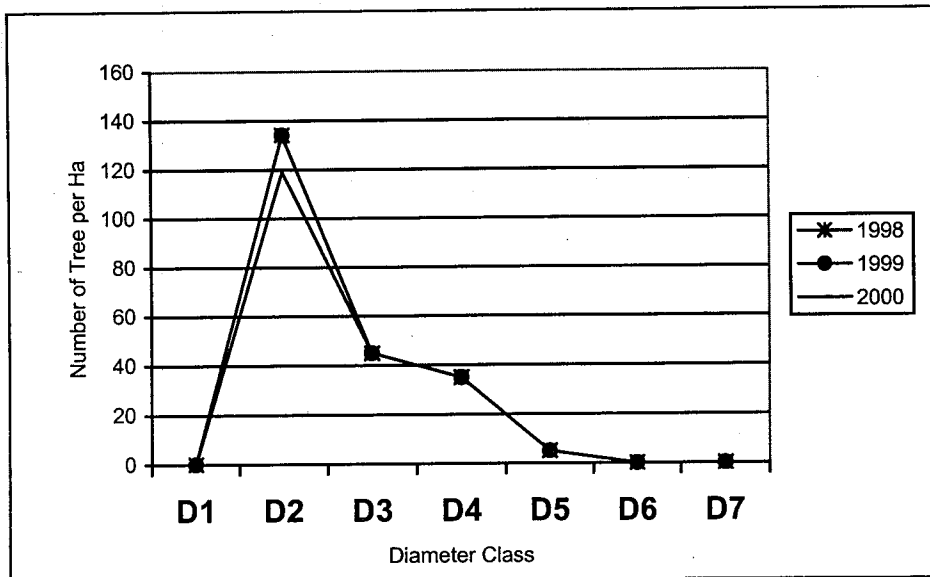

Figure 4. Diameter distribution at plantation forest of *Shorea polyandra* (Cluster 3), Pulau Laut

Notes: D1 = 10 cm – 19.9 cm; D2 = 20 cm – 29.9 cm; D3 = 30 cm – 39.9 cm;  
 D4 = 40 cm – 49.9 cm; D5 = 50 cm – 59.9 cm; D6 = 60 cm – 69.9 cm;  
 D7 = > 70 cm

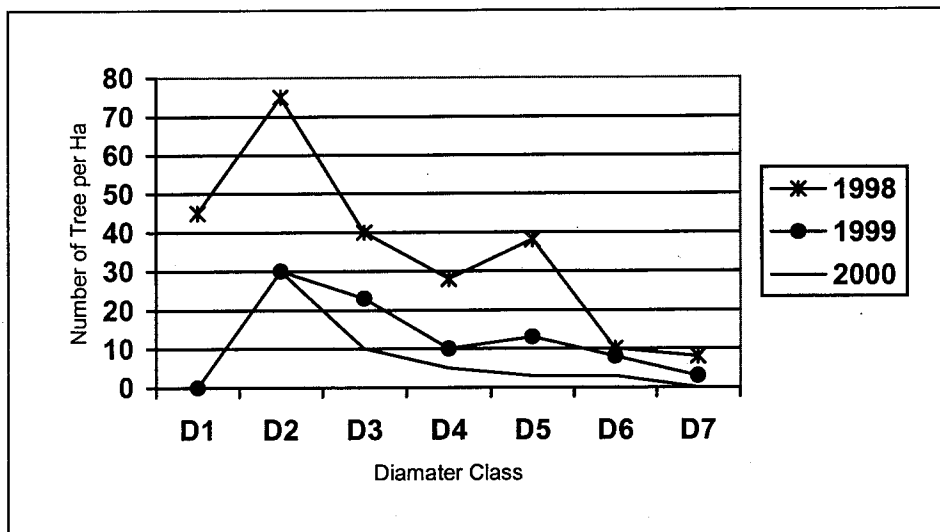

Figure 5. Diameter distribution at seed production area (Cluster 4), Pulau Laut

Notes: D1 = 10 cm – 19.9 cm; D2 = 20 cm – 29.9 cm; D3 = 30 cm – 39.9 cm;  
 D4 = 40 cm – 49.9 cm; D5 = 50 cm – 59.9 cm; D6 = 60 cm – 69.9 cm;  
 D7 = > 70 cm



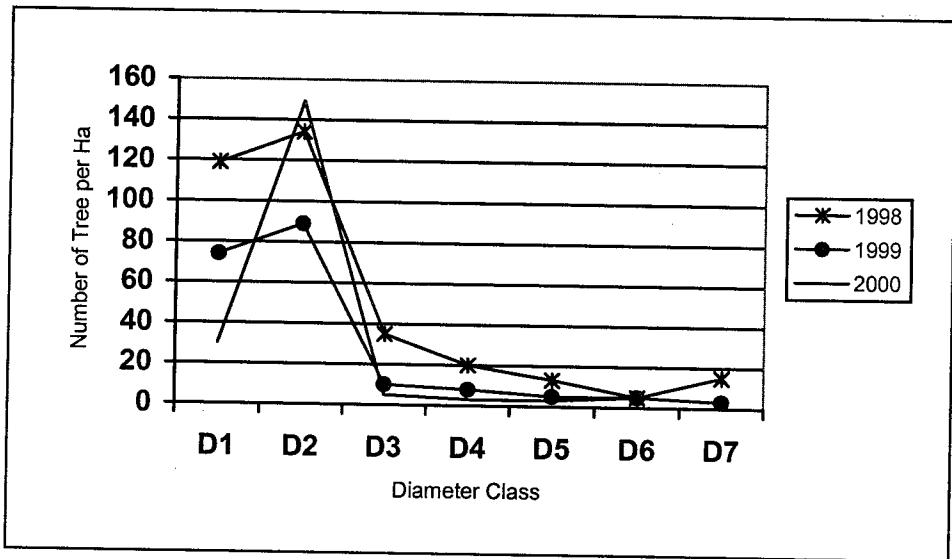

Figure 6. Diameter distribution at seed production area (Cluster 5), Pulau Laut  
 Notes: D1 = 10 cm – 19.9 cm; D2 = 20 cm – 29.9 cm; D3 = 30 cm – 39.9 cm;  
 D4 = 40 cm – 49.9 cm; D5 = 50 cm – 59.9 cm; D6 = 60 cm – 69.9 cm;  
 D7 = > 70 cm

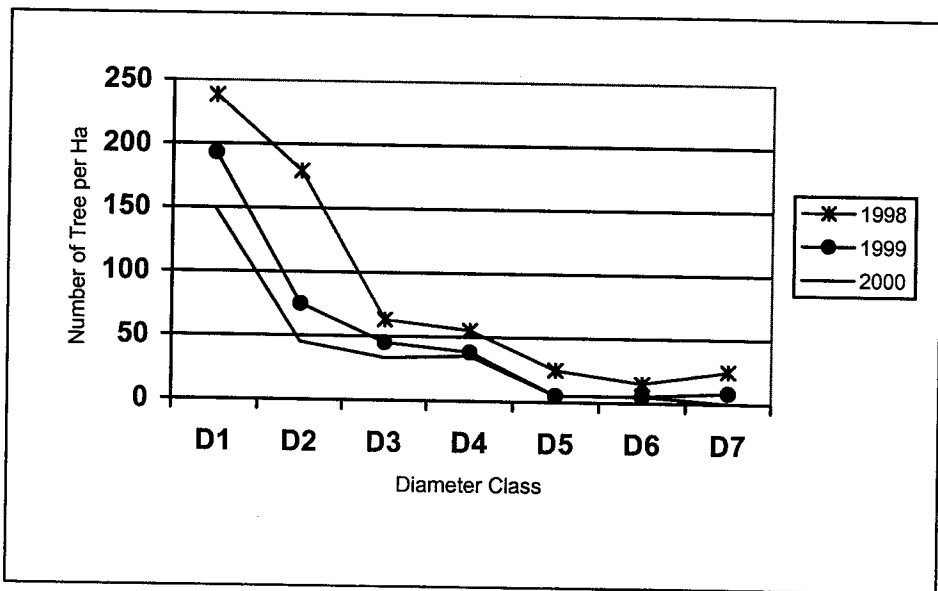

Figure 7. Diameter distribution at seed production area (Cluster 6), Pulau Laut  
 Notes: D1 = 10 cm – 19.9 cm; D2 = 20 cm – 29.9 cm; D3 = 30 cm – 39.9 cm;  
 D4 = 40 cm – 49.9 cm; D5 = 50 cm – 59.9 cm; D6 = 60 cm – 69.9 cm;  
 D7 = > 70 cm

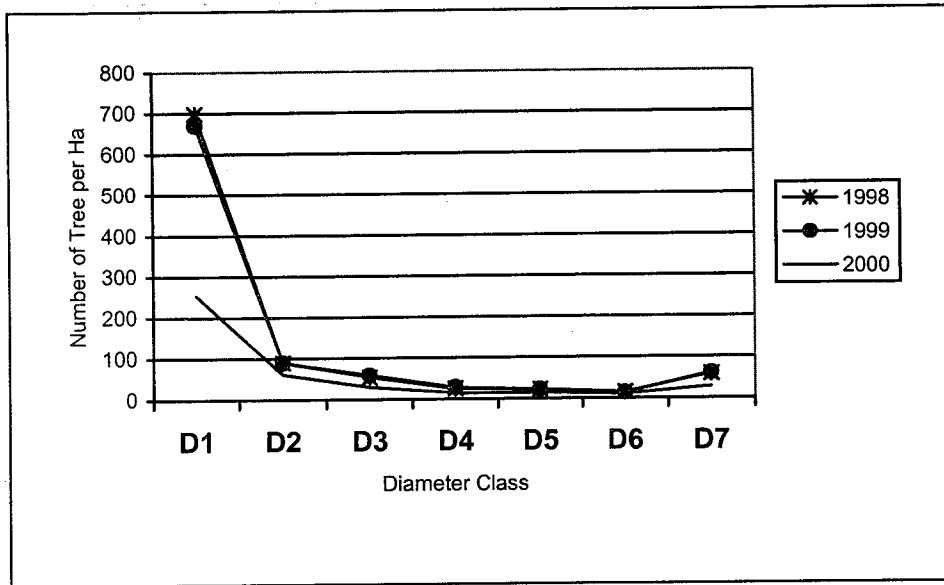

Figure 8. Diameter distribution at logged forest in 1978 (Cluster 7), Pulau Laut  
 Notes: D1 = 10 cm – 19.9 cm; D2 = 20 cm – 29.9 cm; D3 = 30 cm – 39.9 cm;  
 D4 = 40 cm – 49.9 cm; D5 = 50 cm – 59.9 cm; D6 = 60 cm – 69.9 cm;  
 D7 = > 70 cm

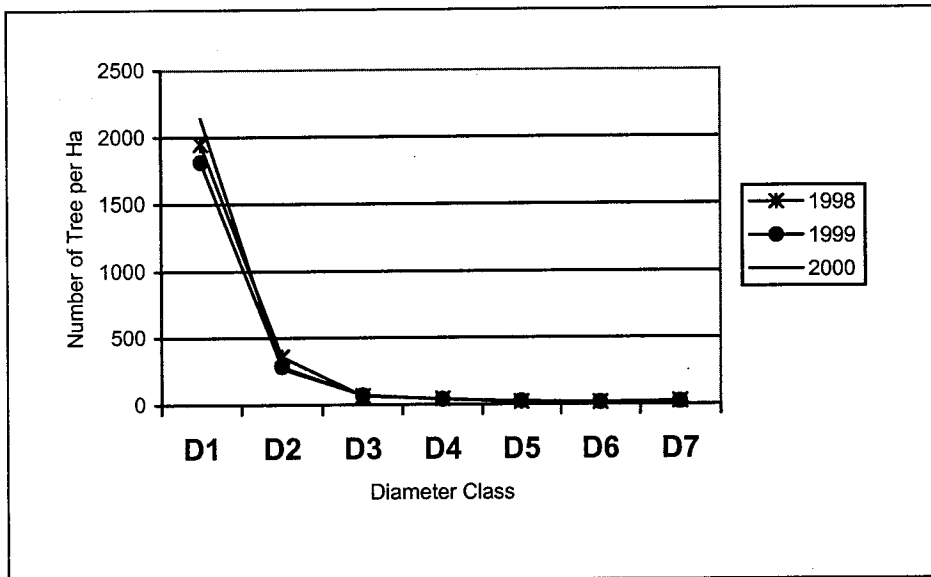

Figure 9. Diameter distribution at natural forest (Cluster 1), Jambi  
 Notes: D1 = 10 cm – 19.9 cm; D2 = 20 cm – 29.9 cm; D3 = 30 cm – 39.9 cm;  
 D4 = 40 cm – 49.9 cm; D5 = 50 cm – 59.9 cm; D6 = 60 cm – 69.9 cm;  
 D7 = > 70 cm

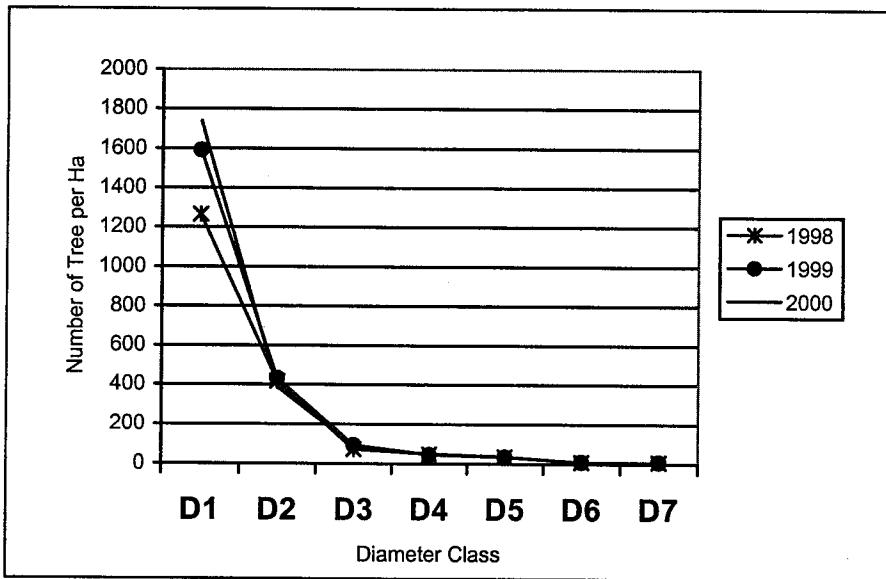

Figure 10. Diameter distribution at natural forest (Cluster 2), Jambi

Notes: D1 = 10 cm – 19.9 cm; D2 = 20 cm – 29.9 cm; D3 = 30 cm – 39.9 cm;  
 D4 = 40 cm – 49.9 cm; D5 = 50 cm – 59.9 cm; D6 = 60 cm – 69.9 cm;  
 D7 = > 70 cm

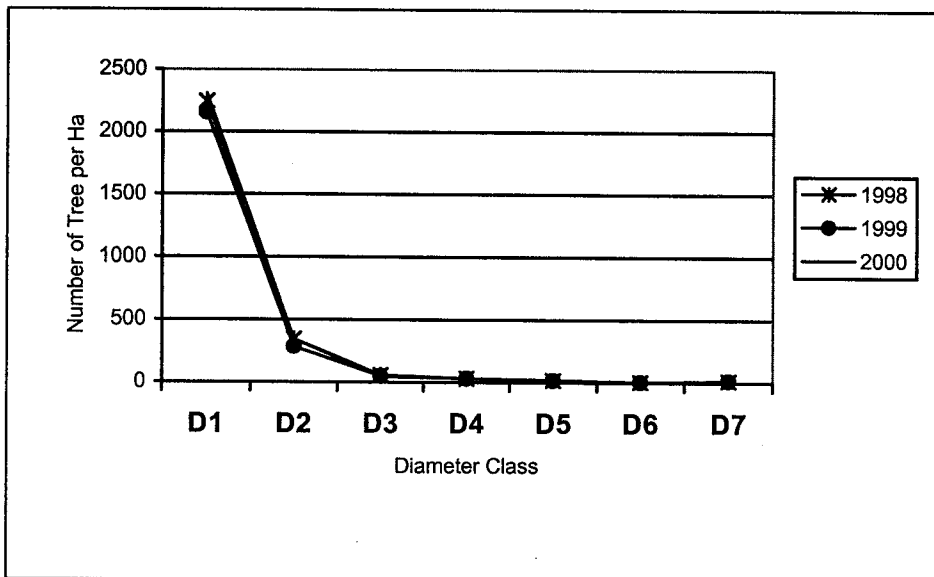

Figure 11. Diameter distribution at seed production area (Cluster 3), Jambi

Notes: D1 = 10 cm – 19.9 cm; D2 = 20 cm – 29.9 cm; D3 = 30 cm – 39.9 cm;  
 D4 = 40 cm – 49.9 cm; D5 = 50 cm – 59.9 cm; D6 = 60 cm – 69.9 cm;  
 D7 = > 70 cm

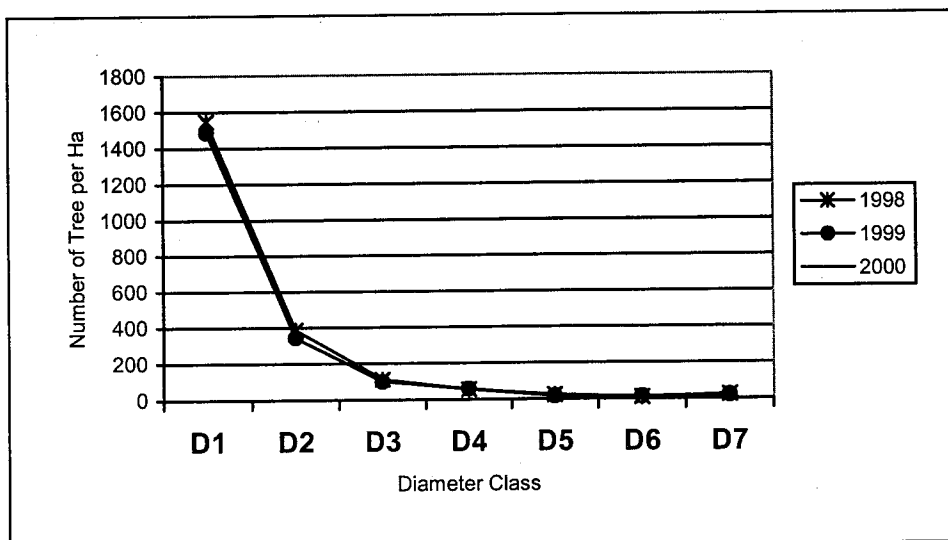

Figure 12. Diameter distribution at natural forest (Cluster 4), Jambi

Notes: D1 = 10 cm – 19.9 cm; D2 = 20 cm – 29.9 cm; D3 = 30 cm – 39.9 cm;  
 D4 = 40 cm – 49.9 cm; D5 = 50 cm – 59.9 cm; D6 = 60 cm – 69.9 cm;  
 D7 = > 70 cm

#### IV. CONCLUSIONS

Regeneration and mortality play important roles in forest health monitoring as indicators towards sustainable forest management in Indonesian tropical rain forest. It will affect the forest structure. Forest fire is the most dangerous factors influencing stand mortality.

#### ACKNOWLEDGEMENT

This Technical Report No. 24 on the **Regeneration and Mortality** has been prepared to fulfill Objective 1 point 1.1 of the Work-plan of ITTO Project PD 16/95 Rev. 2 (F): Forest Health Monitoring to Monitor the Sustainability of Indonesian Tropical Rain Forest.

The authors would like to thank ITTO, Ministry of Forestry (GOI), PT. INHUTANI II, and PT. Asialog Concession for their support. Appreciation also goes to the Project Steering Committee members for their suggestions.

## REFERENCES

- Hamzah Z, 1978. Some observations on the effects of mechanical logging on regeneration, soil and hydrological condition in East Kalimantan. BIOTROP Special Pub. 3: 73-78.
- Lamprecht, 1989. Silviculture in the tropics. GTZ.
- Mangold, R. 1997. Forest Health Monitoring – Field Methods Guide (International – Indonesia 1997). National Forest Health Monitoring Program. Research Triangle Park, USA.
- Ministry of Forestry. 1989. Indonesian Selective Cutting and Replanting System.



# ASSESSMENT ON THE MODIFICATION OF FHM VEGETATION QUADRATES TO ADDRESS TROPICAL SPECIES DIVERSITY OF TREES

*Technical Report No. 25*

Uhaedi Sutisna  
Erianto Indra Putra  
Soekotjo  
Djoko Marsono

## ABSTRACT

Implementation of FHM technology should accommodate the difference in species diversity between tropical and temperate forests. Therefore, it is important to conduct initial evaluation of FHM vegetation quadrates to address tropical species diversity of trees. The initial evaluation was conducted upon the establishment of minimum sample area plots in Jambi, Sumatera, and in Pulau Laut, South Kalimantan. Pulau Laut represents the small island ecosystem with limited species diversity, while Jambi, Sumatera, represents the big island ecosystem with high species diversity. The result showed that the minimal sample area (MSA) cannot be derived both in Jambi which only covered an area of 25.600 m<sup>2</sup> and in Pulau Laut with only an area of 6400 m<sup>2</sup>. Referring to the experiment done by Ashton (1965), the extent of diversity in Jambi will require an MSA of at least four or five hectares. The MSA cannot be implemented at Pulau Laut since the community is dominated by one species (*Shorea polyandra*). Since the MSA cannot be used as a modification of FHM vegetation quadrates, the FHM cluster plot design cannot be modified to meet the tropical species diversity both in the high diversity forest (association type) and in forest with dominance of one species (consociation type). The implementation of FHM cluster plot design at plantation forest can be adopted as it is, since the biodiversity in this area is very limited. In contrast, in the case of areas with high tree species diversity (association type), additional number of the cluster plot should be considered. It means that 4-5 FHM cluster plots must be established for each association type to meet the high species diversity in the tropic.

**Key words:** *Minimal sample area, species diversity, consociation type, association type*

## I. INTRODUCTION

One of the remarkable features of tropical rain forests is their structural diversity and particularly the richness in species and life forms. This condition is different from temperate forest where their species diversity is limited.

Previously, research activities in Forest Health Monitoring have been carried out only on temperate forests. Indonesia is the first country to conduct Forest Health Monitoring (FHM) research for the tropical rain forest. The project entitled Forest Health Monitoring to Monitor the Sustainability of Indonesian Tropical Rain Forest (INDO-FHM). INDO-FHM plans to track down the status, changes and trends of biodiversity in forests of Indonesia, especially on the tree species level.

Referring to Dombois and Ellenberg (1974), regardless of the method used for field analysis, a sample stand for minimum sample area (MSA) should fulfill the following requirements :

1. It should be large enough to contain all species belonging to the plant community
2. The habitat should be uniform within the stand area, as far as one can determine this.
3. The plot cover should be as homogeneous as possible. For example, it should not show the large opening or should not be dominated by one species in one half of the sample area and by a second species in the other half.

The sampling plot design used in the INDO-FHM is called Cluster-plot Design based on Forest Health Monitoring : Field Methods Guide (Alexander and Bernard, 1997). Each plot has a fixed radius of subplot (7.32 m) and annular plot (17.95 m) (see Figure 1). Each cluster contains four subplots/annular plots. Annular plot was used to record the trees, and subplot was used to record the poles. The diversity of poles and trees must be studied.

Implementation of FHM technology should consider the different species diversity between tropical and temperate region. The different condition between temperate and tropical rain forest may effect the species diversity which should be considered. The difference may occur on diversity between annular and subplot. Therefore, it is important to conduct initial evaluation of FHM vegetation quadrates to address the tropical species diversity of trees. The initial evaluation was conducted for the establishment of MSA plots in Jambi, Sumatera and Pulau Laut, South Kalimantan.

The objective of the study was to assess the tropical species diversity as a basis for the modification of the plot size based on the MSA study.

## II. MATERIALS AND METHODS

The basic framework of FHM Cluster-plot is shown in Figure 1.

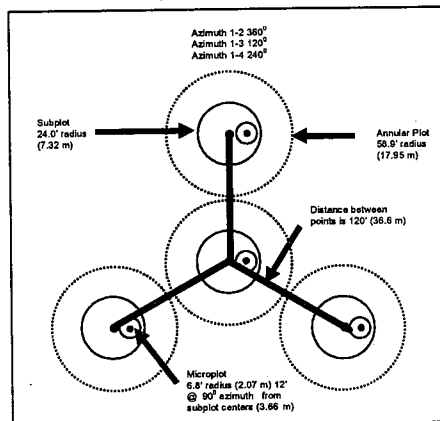

Figure 1. National FHM plot layout is designed around four points (subplot centers)



Assessment on the modification of FHM Vegetation Quadrates to address tropical tree species diversity was conducted in Jambi, Sumatera and Pulau Laut, South Kalimantan. Two minimal sample area (MSA) plots were established in Jambi, Sumatera and Pulau Laut, South Kalimantan. Pulau Laut (South Kalimantan) represents small island ecosystem, while Jambi (Sumatera) represents big island ecosystem. The MSA Plots were based on the sample quadrates system in the form of nested plots described by Dombois and Ellenberg (1974).

A nested plots system for establishing MSA was began by lining out a 100 m<sup>2</sup> plot size and record all species that occur within this area. Then the plot is enlarged to twice the size (200 m<sup>2</sup>), then to four (400 m<sup>2</sup>), until the new species added in the last plot become very few. Each plot is numbered consecutively to include the area of the previous plots.

### 2.1. MSA Study in Jambi, Sumatera

Two hundred and fifty six MSA plots were established in Jambi. Each square plot size was 100 m<sup>2</sup> (10 X 10 m<sup>2</sup>). The total square plot (256) is presented in Figure 2. Figure 3 and Table 1 are presented to summarize all plots for data analysis purposes.

241	242	243	244	245	246	247	248	249	250	251	252	253	254	255	256
240	239	238	237	236	235	234	233	232	231	230	229	228	227	226	225
209	210	211	212	213	214	215	216	217	218	219	220	221	222	223	224
208	207	206	205	204	203	202	201	200	199	198	197	196	195	194	193
177	178	179	180	181	182	183	184	185	186	187	188	189	190	191	192
176	175	174	173	172	171	170	169	168	167	166	165	164	163	162	161
91	92	93	94	95	96	97	98	99	100	155	156	157	158	159	160
81	82	83	84	85	86	87	88	89	90	154	153	152	151	150	149
71	72	73	74	75	76	77	78	79	80	143	144	145	146	147	148
61	62	63	64	65	66	67	68	69	70	142	141	140	139	138	137
51	52	53	54	55	56	57	58	59	60	131	132	133	134	135	136
41	42	43	44	45	46	47	48	49	50	130	129	128	127	126	125
31	32	33	34	35	36	37	38	39	40	119	120	121	122	123	124
21	22	23	24	25	26	27	28	29	30	118	117	116	115	114	113
11	12	13	14	15	16	17	18	19	20	107	108	109	110	111	112
1	2	3	4	5	6	7	8	9	10	106	105	104	103	102	101

Figure 2. MSA Plots Numbering System in Jambi

I	I	I	I	I	I	I	I	I	I	I	I	I	I	I
I	I	I	I	I	I	I	I	I	I	I	I	I	I	I
I	I	I	I	I	I	I	I	I	I	I	I	I	I	I
I	I	I	I	I	I	I	I	I	I	I	I	I	I	I
I	I	I	I	I	I	I	I	I	I	I	I	I	I	I
I	I	I	I	I	I	I	I	I	I	I	I	I	I	I
I	I	I	I	I	I	I	I	I	I	I	I	I	I	I
I	I	I	I	I	I	I	I	I	I	I	I	I	I	I
I	I	I	I	I	I	I	I	I	I	I	I	I	I	I
G	G	G	G	G	G	G	G	H	H	H	H	H	H	H
G	G	G	G	G	G	G	G	H	H	H	H	H	H	H
G	G	G	G	G	G	G	G	H	H	H	H	H	H	H
G	G	G	G	G	G	G	G	H	H	H	H	H	H	H
E	E	E	E	F	F	F	F	H	H	H	H	H	H	H
E	E	E	E	F	F	F	F	H	H	H	H	H	H	H
C	C	D	D	F	F	F	F	H	H	H	H	H	H	H
A	B	D	D	F	F	F	F	H	H	H	H	H	H	H

Figure 3. MSA Plots Layout in Jambi

Table 1. Capital Letters Represent the Sample Size on MSA Plot, Jambi

No	Sample Size (m <sup>2</sup> )	Letters	No	Sample Size (m <sup>2</sup> )	Letters
1	100	A	5	1600	A, B, C, D, E
2	200	A, B	6	3200	A, B, C, D, E, F
3	400	A, B, C	7	6400	A, B, C, D, E, F, G
4	800	A, B, C, D	8	12800	A, B, C, D, E, F, G, H
			9	25600	A, B, C, D, E, F, G, H, I

To assess the plot size of FHM, the species found in the MSA plots were classified into two categories : poles (the species having the diameter 10-19.9 cm), and trees (the species having the diameter more than 20 cm).

The increment on species number is counted by the formula of Soerianegara and Indrawan (1974):

Where :  $S_x$  : number of species in x sample size  
 $S_{(x-1)}$  : number of species in the sample size before x

## 2.2. MSA Study in Pulau Laut, South Kalimantan

*Shorea polyandra* is a dominant species in forest community at Pulau Laut (South Kalimantan). It was suspected that the tree diversity in this area is very limited, only one hundred MSA plots of 10 X 10 m<sup>2</sup> were established (Figure 4). Sixty-four plots were taken to make a species area curve. Figure 5 and Table 2 are presented to summarize the sixty-four plots for data analysis purposes.

91	92	93	94	95	96	97	98	99	100
81	82	83	84	85	86	87	88	89	90
71	72	73	74	75	76	77	78	79	80
61	62	63	64	65	66	67	68	69	70
51	52	53	54	55	56	57	58	59	60
41	42	43	44	45	46	47	48	49	50
31	32	33	34	35	36	37	38	39	40
21	22	23	24	25	26	27	28	29	30
11	12	13	14	15	16	17	18	19	20
1	2	3	4	5	6	7	8	9	10

Figure 4. MSA Plots Numbering System in Pulau Laut

G	G	G	G	G	G	G	G
G	G	G	G	G	G	G	G
G	G	G	G	G	G	G	G
G	G	G	G	G	G	G	G
E	E	E	E	F	F	F	F
E	E	E	E	F	F	F	F
C	C	D	D	F	F	F	F
A	B	D	D	F	F	F	F

Figure 5. MSA Plots Layout in Pulau Laut

Table 2. Capital Letters Represent the Sample Size on MSA Plot, Pulau Laut

No	Sample Size (m <sup>2</sup> )	Letters
1	100	A
2	200	A, B
3	400	A, B, C
4	800	A, B, C, D
5	1600	A, B, C, D, E
6	3200	A, B, C, D, E, F
7	6400	A, B, C, D, E, F, G

To assess the plot size of FHM, the species found in the MSA plots were classified into two categories : poles (the species having the diameter 10-19.9 cm), and trees (the species having the diameter more than 20 cm).

The increment on species number is counted by the formula of Soerianegara and Indrawan (1974):

$$\frac{(S_x - S_{(x-1)})}{S_x}$$

Where :  $S_x$  : number of species in x sample size  
 $S_{(x-1)}$  : number of species in the sample size before x

### III. RESULTS AND DISCUSSIONS

The number of species found in each MSA plot at Jambi is presented in Tables 3-5, while for Pulau Laut in Tables 6-8.

Table 3. All species (trees + poles) increment in MSA plots, Jambi

No	Number of plot	Plot Size (m <sup>2</sup> )	Cumulative total Numbers of Species			All species (trees + poles)	
			Poles species	Trees species	All species (trees + poles)	Number of new species found	Increment (%)
1.	1	100	4	1	5	5	-
2.	2	200	5	3	8	3	60
3.	4	400	13	5	18	10	125
4.	8	800	18	8	23	5	27.78
5.	16	1600	35	16	42	19	82.61
6.	32	3200	60	36	74	32	76.19
7.	64	6400	86	54	104	30	40.54
8.	128	12800	120	94	149	45	43.27
9.	256	25600	182	140	215	66	44.29

Table 4. Tree species increment in MSA plots, Jambi

No	Number Of Plots	Plot Size (m <sup>2</sup> )	Number of New Species Found	Cumulative Total Number of Species	Increment (%)
1.	1	100	1	1	-
2.	2	200	2	3	200
3.	4	400	2	5	66.67
4.	8	800	3	8	60
5.	16	1600	8	16	100
6.	32	3200	20	36	125
7.	64	6400	18	54	50
8.	128	12800	40	94	74.07
9.	256	25600	46	140	48.94

Table 5. Pole species increment in MSA plots, Jambi

No	Number Of Plots	Plot Size (m <sup>2</sup> )	Number of New Species Found	Cumulative Total Number of Species	Increment (%)
1.	1	100	4	4	-
2.	2	200	1	5	25
3.	4	400	8	13	160
4.	8	800	5	18	38.46
5.	16	1600	17	35	94.44
6.	32	3200	25	60	71.43
7.	64	6400	26	86	43.33
8.	128	12800	34	120	39.53
9.	256	25600	62	182	51.67

Table 6. All species (trees + poles) increment in MSA plots, Pulau Laut

No	Number of plot	Plot Size (m <sup>2</sup> )	Cumulative total Numbers of Species			All species (trees + poles)	
			Poles species	Trees species	All species (trees + poles)	Number of new species found	Increment (%)
1.	1	100	1	2	2	2	-
2.	2	200	1	2	2	0	0
3.	4	400	1	2	2	0	0
4.	8	800	1	6	6	4	200
5.	16	1600	2	10	10	4	66.67
6.	32	3200	5	14	16	6	60
7.	64	6400	9	19	23	7	43.75

Table 7. Tree species increment in MSA plots, Pulau Laut

No	Number Of Plots	Plot Size (m <sup>2</sup> )	Number of New Species Found	Cumulative Total Number of Species	Increment (%)
1.	1	100	2	2	-
2.	2	200	0	2	0
3.	4	400	0	2	0
4.	8	800	4	6	200
5.	16	1600	4	10	66.67
6.	32	3200	4	14	40
7.	64	6400	5	19	35.71

Table 8. Pole species increment in MSA plots, Pulau Laut

No	Number Of Plots	Plot Size (m <sup>2</sup> )	Number of New Species Found	Cumulative Total Number of Species	Increment (%)
1.	1	100	1	1	-
2.	2	200	0	1	0
3.	4	400	0	1	0
4.	8	800	0	1	0
5.	16	1600	1	2	100
6.	32	3200	3	5	150
7.	64	6400	4	9	80

Minimal sample area (MSA) is defined as the smallest area on which the species composition of the community in question is adequately represented. The smallest area gives an indication of the quadrat size that should be used. Based on the Cain's method, the minimal sample area is obtained when the curve flattens at a faster rate or if initial steeply increasing curve becomes almost horizontal where a 10 percent increase in area yields only an additional 10 percent species.

The plotted species number over a size of sample area in Jambi and Pulau Laut showed that the curve slope as still increasing (Figures 6 – 9). It shows that the minimal sample area was not found both in Jambi (plot size of 25600 m<sup>2</sup>) and Pulau Laut (plot size of 6400 m<sup>2</sup>).

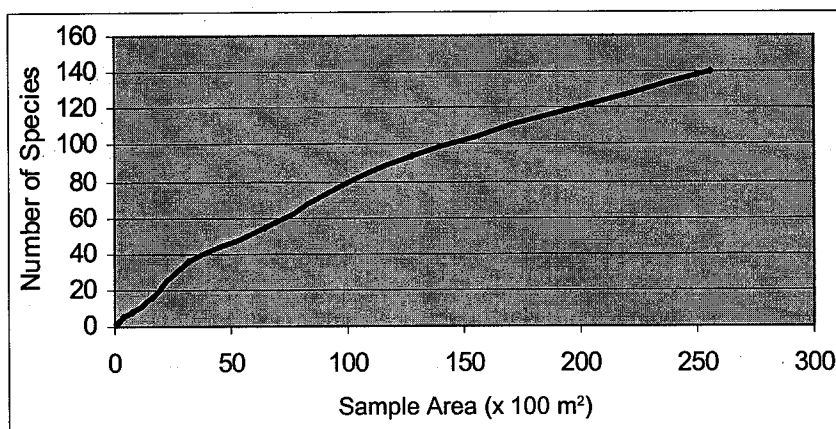

Figure 6. Trees Species Area Curve in Jambi

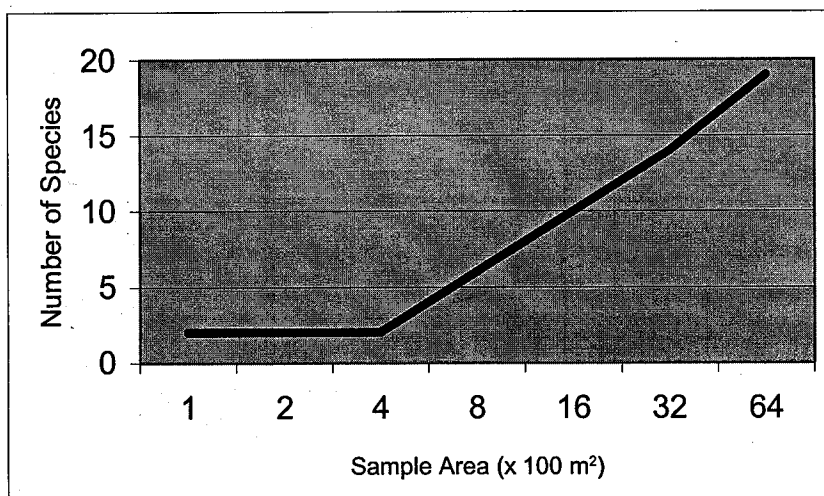

Figure 7. Poles Species Area Curve in Jambi

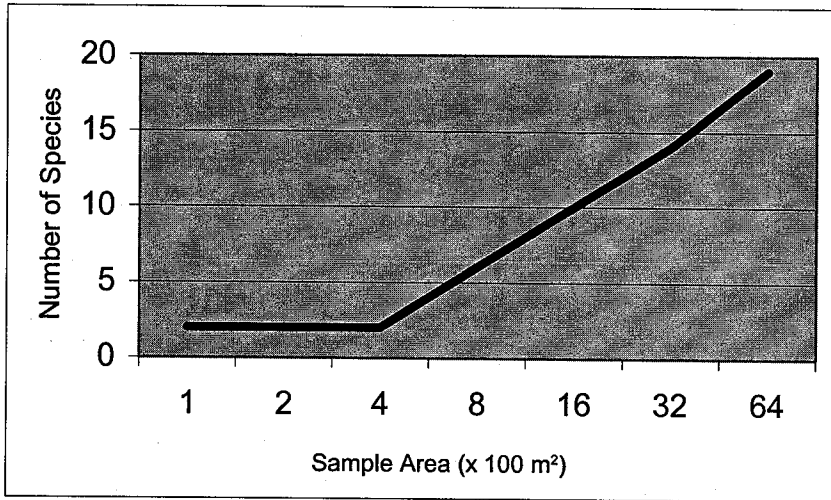

Figure 8. Trees Species Area Curve in Pulau Laut

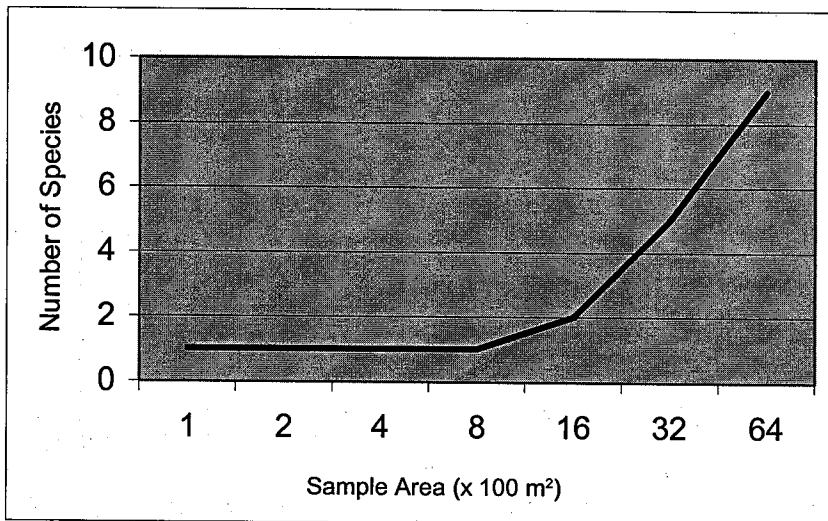

Figure 9. Poles Species Area Curve in Pulau Laut

Since the species diversity in Jambi was very high (association type), the minimal sample area will be obtained in a large size at probably 4 or 5 hectares. The most-likely cases in this kind of MSA assessment is also found at six species area curves tested in tropical rain forests in Borneo (Dombois and Ellenberg, 1974) (Figure 9). Only the lowest curve from Belalong shows a clear trend of leveling-off that tends a 0.5 acre minimal area could be considered satisfactory in this community. In the other communities even a 5 acre (or 2 hectares) seems too small that makes the minimal area of these communities is probably around 5 hectares that makes it is necessary to make a compromise on this communities (Dombois and Ellenberg, 1974).

Dombois and Ellenberg (1974) gives another suggestion in determining the minimal area by setting an objective standard through the total number of species sampled. With this approach, one may require that the minimal area should contain at least 90 or 95 percent of the maximum number of species encountered in the largest sample unit of the nested plot.

Using the assumption that the minimal area contains 90% of the maximum number of species, with the total number of species encountered in the largest plot area (25600 m<sup>2</sup>) will be 140, 182, and 215 for trees, poles, and all species (trees + poles) respectively. The minimal area in Jambi is counted as 23,040 m<sup>2</sup> for all communities : tree species, pole species, and all species (trees + poles) (Table 9).

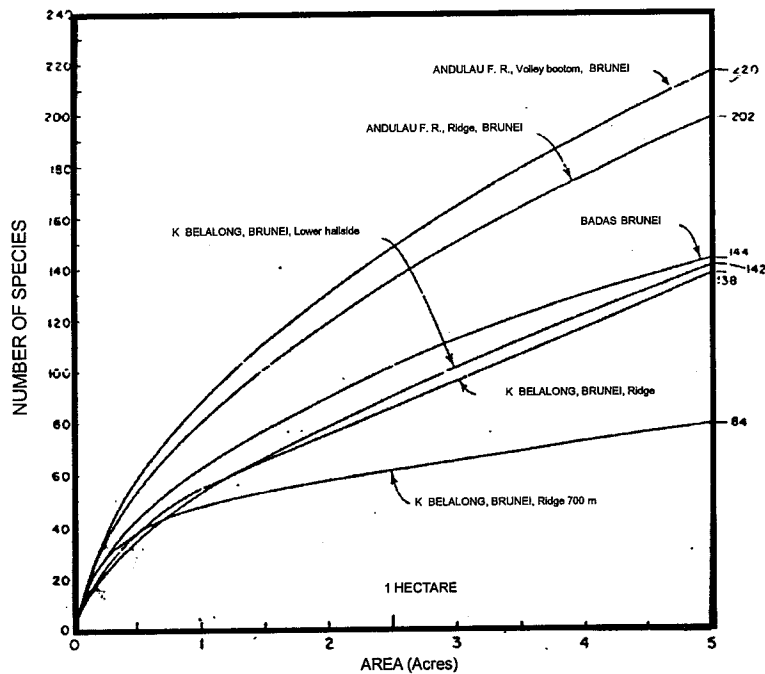

Figure 10. Species area curves for sites in Brunei

Table 9. The calculation of minimal area on Jambi communities

	Total number of species	90 % of number of species	Minimal area (m <sup>2</sup> )
<b>Tree species</b>	140	126	23,040
<b>Pole species</b>	182	163.8	23,040
<b>All Species (Trees + Poles)</b>	215	193.5	23,040

The minimum area of 23,040 m<sup>2</sup> (or 2,304 hectares) seems too large to meet the FHM Plot Design. To relate the MSA for assessing the species biodiversity is quite difficult, since MSA represent the number of species only. Consequently, the observation using other parameter to assess the species diversity is needed. MSA represents in a specific area only, and it does not cover all the area.



FHM Cluster-plot design covers 0.4 hectare per cluster-plots. As the INDO-FHM plans to track down the diversity of Indonesian tropical rain forest, the number of plot should represent the overall species diversity of the selected area. When the system is tested in the association forest type with high diversity as found in Jambi, the plot design should be modified.

However, one must choose to work with a relevant size that is practical and manageable, even if it contains only a fraction of the number of species of the community type (Dombois and Ellenberg, 1974). Moreover, the practical and manageable plot size is one of important things to be considered and required before making a periodically scientific measurement on the area.

FHM cluster-plot area of 0.4 hectare represents 1 hectares area. It means that to meet the estimation of 5 hectares as a minimal area in Jambi, at least five cluster-plots must be established in a certain ecosystem in order to record representative species richness.

Different case was found in Pulau Laut, South Kalimantan. As *Shorea polyandra* was the dominant species, tropical forest in Pulau Laut then is grouped as consociation type forest. The minimal sample area will never been obtained in this consociation forest, as the increase of 1 species will made the curve slope changed dramatically. Moreover, when *Shorea polyandra* is dominant species in this community, one of the requirements needed for the establishment of MSA plots does not meet. The plot should not be dominated by one species.

The MSA plots cannot be implemented in the consociation type forest. Consequently, it is not necessary to make a modification on FHM vegetation quadrates. FHM Cluster-plot design in this area (consociation type or plantation forest) can be adopted as it is without any modification in their plot design.

#### IV. CONCLUSIONS

High species diversity at Jambi' tropical rain forest makes the species area curve still increasing steeply in the sample area of 25,600 m<sup>2</sup>, and the minimal species area probably found at 4 or 5 hectares as the cases reported by Dombois and Ellenberg (1974) in tropical rain forest of Borneo. Using another approach of determining the minimal sample area in Jambi gives the result of 23,040 m<sup>2</sup> as the minimal area. The large area will makes its hard to manage and impractical. On other hand, the parameters based on minimal sample area are only valid for the measurement on that area. These two considerations make minimal sample area cannot be used as a modification of FHM vegetation quadrates.

The requirement needed for the establishment of MSA was not met at Pulau Laut since the area is dominated by one species (*Shorea polyandra*). Consequently, the MSA cannot be adopted in the forest with one dominant species at the community.

These are indicators that both in the high diversity forest (association type) and in forest with dominance of one species (consociation type), the FHM Cluster-plot design can not be modified to meet the tropical species diversity.

In the implementation of FHM Cluster-plot design at plantation forest can be adopted as it is since the biodiversity in this area is very limited. In contrast, in the case of area with high tree species diversity (association type), additional number of the cluster-plot (4-5 cluster-plots) should be considered.

### ACKNOWLEDGEMENT

This Technical Report No. 25 on the **Assessment on Modification of FHM Vegetation Quadrates to Address Tropical Species Diversity of Trees** has been prepared to fulfill Objective 2 point 3.2. of the Work-plan of ITTO Project PD 16/95 Rev. 2 (F): Forest Health Monitoring to Monitor the Sustainability of Indonesian Tropical Rain Forest.

The authors would like to thank ITTO, Ministry of Forestry (GOI), PT. INHUTANI II and PT. Asialog Forest Concession Holder for their support. Appreciation also goes to the Project Steering Committee members for their suggestions.

### REFERENCES

- Alexander, S.A. and J.E. Barnard. 1997. Forest Health Monitoring : Field Methods Guide (International – Indonesia). USDA Forest Service. Research Triangle Park, NC.
- Dombois, D.E. and H. Ellenberg. 1974. Aims and Methods of Vegetation Ecology. John Wiley and Sons. New York.
- Soerianegara, I, and A. Indrawan. 1974. Ekologi Hutan Indonesia. Fakultas Kehutanan IPB. Bogor, Indonesia.

Annex 1. List of tree species and its diameter class on MSA plots, Jambi

No.	FHM ID	Species	Family	10-19.9 cm	20 cm up
1	Aglgan	<i>Aglaia ganggo</i>	Meliaceae	+	-
2	Aglsp1	<i>Aglaia</i> sp.	Meliaceae	+	-
3	Agltom	<i>Aglaia tomentosa</i>	Meliaceae	+	+
4	Alajav	<i>Alangium javanicum</i>	Alangiaceae	+	+
5	Alsang	<i>Alstonia angustiloba</i>	Apocynaceae	+	+
6	Alsban	<i>Alseodaphne bancana</i>	Lauraceae	+	+
7	Alsped	<i>Alseodaphne peduncularis</i>	Lauraceae	+	+
8	Annsp1	<i>Anonaceae</i> sp.	Annonaceae	+	-
9	Antbun	<i>Antidesma bunius</i>	Euphorbiaceae	+	-
10	Antsp1	<i>Antidesma</i> sp.	Euphorbiaceae	+	+
11	Anttet	<i>Antidesma tetandrum</i>	Euphorbiaceae	+	-
12	Aposp1	<i>Aporusa</i> sp.	Euphorbiaceae	+	-
13	Aposph	<i>Aporusa sphaeridophora</i>	Euphorbiaceae	+	+
14	Aqumal	<i>Aquilaria malaccensis</i>	Thymelaeaceae	+	+
15	Arccly	<i>Archidendron clypearia</i>	Mimosaceae	+	-
16	Ardhum	<i>Ardisia humilis</i>	Myrsinaceae	+	+
17	Aroele	<i>Aromadendron elegans</i>	Magnoliaceae	+	-
18	Artela	<i>Artocarpus elasticus</i>	Moraceae	+	+
19	Artful	<i>Artocarpus fulvicortex</i>	Moraceae	+	-
20	Artint	<i>Artocarpus integer</i>	Moraceae	+	+
21	Artkem	<i>Artocarpus kemando</i>	Moraceae	+	+
22	Artlon	<i>Artocarpus longifolius</i>	Moraceae	+	-
23	Artnit	<i>Artocarpus nitidus</i>	Moraceae	+	+
24	Artrig	<i>Artocarpus rigidus</i>	Moraceae	+	+
25	Bacbra	<i>Baccaurea bracteata</i>	Euphorbiaceae	+	+
26	Bacdef	<i>Baccaurea deflexa</i>	Euphorbiaceae	+	+
27	Bacsp1	<i>Baccaurea</i> sp.	Euphorbiaceae	+	+
28	Bacsum	<i>Baccaurea sumatrana</i>	Euphorbiaceae	+	-
29	Barsp1	<i>Barringtonia</i> sp.	Lecythidaceae	+	+
30	Beikun	<i>Beilschmiedia kuntzleri</i>	Lauraceae	+	-
31	Beiwig	<i>Beilschmiedia wightii</i>	Lauraceae	+	+
32	Bhepan	<i>Bhesa paniculata</i>	Celastraceae	+	+
33	Bherob	<i>Bhesa robusta</i>	Celastraceae	+	-
34	Blutok	<i>Blumeodendron tokbrai</i>	Euphorbiaceae	+	-
35	Bouopp	<i>Bouea oppositifolia</i>	Anacardiaceae	+	+
36	Calpul	<i>Calophyllum pulcherrimum</i>	Guttiferae	+	+
37	Calret	<i>Calophyllum retusum</i>	Gutteraceae	+	+
38	Candic	<i>Canarium dichotomum</i>	Burseraceae	+	-
39	Canlit	<i>Canarium littorale</i>	Burseraceae	+	+
40	Canpil	<i>Canarium pillosum</i>	Burseraceae	+	-
41	Carbra	<i>Carallia brachiata</i>	Rhizoporaceae	+	+
42	Chrlan	<i>Chrysophyllum lanceolatum</i>	Sapotaceae	+	+
43	Cinpar	<i>Cinnamomum partenoxylon</i>	Lauraceae	+	+
44	Cinpor	<i>Cinnamomum porectum</i>	Lauraceae	+	-
45	Coegri	<i>Coelostegia griffithii</i>	Bombacaceae	+	+
46	Craarb	<i>Cratoxylum arborescens</i>	Hypericaceae	+	+
47	Cralig	<i>Cratoxylum ligustrinum</i>	Hypericaceae	+	-

No.	FHM ID	Species	Family	10-19.9 cm	20 cm up
48	Croarg	<i>Croton argyratus</i>	Euphorbiaceae	+	+
49	Crusp1	<i>Crudia</i> sp.	Caesalpinaceae	+	-
50	Crute1	<i>Crudia teysmannii</i>	Caesalpinaceae	+	-
51	Crysp1	<i>Cryptocarya</i> sp.	Lauraceae	+	-
52	Ctepar	<i>Ctenolophon parvifolius</i>	Linaceae	+	+
53	Ctesp1	<i>Ctenolophon</i> sp.	Linaceae	+	+
54	Cyaban	<i>Cyathocalyx bancana</i>	Annonaceae	+	+
55	Daccos	<i>Dacryodes costata</i>	Burseraceae	+	+
56	Daccra	<i>Dacryodes crasipes</i>	Burseraceae	+	-
57	Dacinc	<i>Dacryodes incurvata</i>	Burseraceae	+	+
58	Dacros	<i>Dacryodes rostrata</i>	Burseraceae	+	+
59	Dehaae	<i>Dehaasia caesia</i>	Lauraceae	+	-
60	Dehcun	<i>Dehaasia cuneata</i>	Lauraceae	+	+
61	Diaind	<i>Dialium indum</i>	Caesalpinaceae	+	+
62	Diapla	<i>Dialium platycephalum</i>	Caesalpinaceae	+	+
63	Dilexi	<i>Dillenia eximia</i>	Dilleniaceae	+	+
64	Dilobo	<i>Dillenia obovata</i>	Cornaceae	+	-
65	Dilsum	<i>Dillenia sumatrana</i>	Dilleniaceae	+	-
66	Dioheb	<i>Diospyros hebecarpa</i>	Ebenaceae	+	-
67	Diolae	<i>Diospyros laevigata</i>	Ebenaceae	+	+
68	Diomal	<i>Diospyros malabarica</i>	Ebenaceae	+	+
69	Diopse	<i>Diospyros pseudomalabarica</i>	Ebenaceae	+	+
70	Diosim	<i>Diospyros simalurensis</i>	Ebenaceae	+	-
71	Dradao	<i>Dracontomelon dao</i>	Anacardiaceae	+	+
72	Driur	<i>Drimycarpus luridus</i>	Anacardiaceae	+	-
73	Drysp1	<i>Drypetes</i> sp.	Euphorbiaceae	+	-
74	Durgri	<i>Durio griffithii</i>	Bombacaceae	+	-
75	Duroxl	<i>Durio oxleyanus</i>	Bombacaceae	+	+
76	Dyecos	<i>Dyera costulata</i>	Apocynaceae	+	+
78	Dyssp1	<i>Dysoxylum</i> sp.	Meliaceae	+	+
78	Elaflo	<i>Elaeocarpus floribundus</i>	Elaeocarpaceae	+	+
79	Elasp1	<i>Elaeocarpus</i> sp.	Elaeocarpaceae	+	+
80	Enddia	<i>Endospermum diadenum</i>	Euphorbiaceae	+	+
81	Engser	<i>Engelhardtia serrata</i>	Juglandaceae	+	-
82	Erycun	<i>Erythroxylon cuneatum</i>	Erythricaceae	+	-
83	Euglin	<i>Eugenia lineata</i>	Myrtaceae	+	+
84	Eugsp1	<i>Eugenia</i> sp.	Myrtaceae	+	+
85	Euoluc	<i>Euodia lucida</i>	Rutaceae	+	+
86	Galsp1	<i>Galearia</i> sp.	Euphorbiaceae	+	+
87	Garani	<i>Gardenia anisophyllea</i>	Rubiaceae	+	-
89	Gardio	<i>Garcinia dioica</i>	Guttaceae	+	+
89	Garfor	<i>Gardenia forsteniana</i>	Rubiaceae	+	-
90	Garner	<i>Garcinia nervosa</i>	Guttaceae	+	+
91	Garsp1	<i>Garcinia</i> sp.	Guttaceae	+	+
92	Garsp2	<i>Gardenia</i> sp.	Rubiaceae	+	-
93	Girsub	<i>Gironniera subaequalis</i>	Ulmaceae	+	+
94	Gonmai	<i>Gonystylus maingayi</i>	Thymelaeaceae	+	+
95	Gonvel	<i>Gonystylus velutinus</i>	Thymelaeaceae	+	-
96	Gymban	<i>Gymnacranthera bancana</i>	Myristicaceae	+	+

No.	FHM ID	Species	Family	10-19.9 cm	20 cm up
97	Gymeug	<i>Gymnacranthera eugeniifolia</i>	Myristicaceae	+	+
98	Gymfor	<i>Gymnacranthera forbesii</i>	Myristicaceae	+	+
99	Gynaxi	<i>Gynotroches axillaris</i>	Rhizophoraceae	+	+
100	Hersum	<i>Heritiera sumatrana</i>	Sterculiaceae	+	-
101	Hopdry	<i>Hopea dryobalanoides</i>	Dipterocarpaceae	+	+
102	Hopmen	<i>Hopea mengarawan</i>	Dipterocarpaceae	+	-
103	Horsp1	<i>Horsfieldia</i> sp.	Myristicaceae	+	-
104	Horwal	<i>Horsfieldia wallichii</i>	Myristicaceae	+	+
105	Hydwoo	<i>Hydnocarpus woodii</i>	Flacourtiaceae	+	+
106	Ilebog	<i>Ilex bogoriensis</i>	Aquifoliaceae	+	-
107	Intpal	<i>Intsia palembanica</i>	Caesalpiniaceae	+	-
108	Irvmal	<i>Irvingia malayana</i>	Simarubaceae	+	+
109	Ixoico	<i>Ixonanthes icosandra</i>	Linaceae	+	+
110	Kibmai	<i>Kibatalia maingayi</i>	Apocinaceae	+	+
111	Knecin	<i>Knema cinerea</i>	Myristicaceae	+	+
112	Knelat	<i>Knema latifolia</i>	Myristicaceae	+	+
113	Knelau	<i>Knema laurina</i>	Myristicaceae	+	-
114	Knemal	<i>Knema malayana</i>	Myristicaceae	+	+
115	Kneman	<i>Knema mandarahan</i>	Myristicaceae	+	+
116	Koomal	<i>Koompassia malaccensis</i>	Caesalpiniaceae	+	+
117	Koshet	<i>Kostermanthus heteropetalus</i>	Rosaceae	+	+
118	Lithys	<i>Lithocarpus hystrix</i>	Fagaceae	+	+
119	Litsp1	<i>Litsea</i> sp.	Lauraceae	+	+
120	Maccon	<i>Macaranga conifera</i>	Euphorbiaceae	+	+
121	Madpay	<i>Madhuca payenoides</i>	Sapotaceae	+	-
122	Madser	<i>Madhuca sericea</i>	Sapotaceae	+	+
123	Magele	<i>Magnolia elegans</i>	Magnoliaceae	+	-
124	Malpen	<i>Mallotus penangensis</i>	Euphorbiaceae	+	+
125	Manfoe	<i>Mangifera foetida</i>	Anacardiaceae	+	+
126	Mansp1	<i>Mangifera</i> sp.	Anacardiaceae	+	+
127	Masbra	<i>Mastixia bracteata</i>	Cornaceae	+	-
128	Mastri	<i>Mastixia trichotoma</i>	Cornaceae	+	+
129	Melsp1	<i>Melicope</i> sp.	Ruteaceae	+	-
130	Melsp2	<i>Meliosma</i> sp.	Sabiaceae	+	-
131	Melsp3	<i>Melanochyla</i> sp.	Anacardiaceae	+	+
132	Memcos	<i>Memecylon costatum</i>	Melastomataceae	+	+
133	Memlae	<i>Memecylon laevigatum</i>	Melastomataceae	+	-
134	Memmul	<i>Memecylon multiflorum</i>	Melastomataceae	+	-
135	Memsp1	<i>Memecylon</i> sp.	Melastomataceae	+	+
136	Milatr	<i>Millettia atropurpurea</i>	Papilionaceae	+	+
137	Milser	<i>Millettia sericea</i>	Papilionaceae	+	-
138	Myrine	<i>Myristica iners</i>	Myristicaceae	+	-
139	Myrsp1	<i>Myristica</i> sp.	Myristicaceae	+	-
140	Neokin	<i>Neoscortechinia kingii</i>	Euphorbiaceae	+	-
141	Nepcus	<i>Nephelium cuspidatum</i>	Sapindaceae	+	+
142	Neplap	<i>Nephelium lappaceum</i>	Sapindaceae	+	-
143	Nepmut	<i>Nephelium mutabile</i>	Sapindaceae	+	-
144	Nepsp1	<i>Nephelium</i> sp.	Sapindaceae	+	+
145	Ochame	<i>Ochanostachys amentacea</i>	Olcaceae	+	+

No.	FHM ID	Species	Family	10-19.9 cm	20 cm up
146	Palgut	<i>Palaquium gutta</i>	Sapotaceae	+	+
147	Palros	<i>Palaquium rostratum</i>	Sapotaceae	+	+
148	Parspe	<i>Parkia speciosa</i>	Mimosaceae	+	+
149	Parbra	<i>Parartocarpus bracteolatus</i>	Moraceae	+	+
150	Parobl	<i>Parinari oblongifolia</i>	Rosaceae	+	-
151	Parsum	<i>Parinari sumatrana</i>	Rosaceae	+	+
152	Payacu	<i>Payena acuminata</i>	Sapotaceae	+	-
153	Payend	<i>Payena endertii</i>	Sapotaceae	+	+
154	Paylee	<i>Payena leeri</i>	Sapotaceae	+	+
155	Penpol	<i>Pentace polyantha</i>	Tiliaceae	+	+
156	Pentri	<i>Pentace triptera</i>	Tiliaceae	+	-
157	Pereur	<i>Pertusadina euryncha</i>	Rubiaceae	+	+
158	Phomac	<i>Phoebe macrophylla</i>	Lauraceae	+	-
159	Pimgri	<i>Pimelodendron griffithianum</i>	Euphorbiaceae	+	+
160	Plecon	<i>Plectronia conferta</i>	Rubiaceae	+	-
161	Polgla	<i>Polyalthia glauca</i>	Annonaceae	+	+
162	Polhyp	<i>Polyalthia hypoleuca</i>	Annonaceae	+	+
163	Pompin	<i>Pometia pinnata</i>	Sapindaceae	+	+
164	Poumal	<i>Pouteria malaccensis</i>	Sapotaceae	+	+
165	Pralim	<i>Prairiea limpato</i>	Moraceae	+	-
166	Prugri	<i>Prunus grisea</i>	Rosaceae	+	+
167	Ptecoe	<i>Pternandra coerulescens</i>	Melastomataceae	+	+
168	Ptysp1	<i>Ptychopyxis</i> sp.	Euphorbiaceae	+	+
169	Queben	<i>Quercus bennettii</i>	Fagaceae	+	+
170	Queoid	<i>Quercus odocarpa</i>	Fagaceae	+	+
171	Quesp1	<i>Quercus</i> sp.	Fagaceae	+	-
172	Quesub	<i>Quercus subsericea</i>	Fagaceae	+	-
173	Rhocin	<i>Rhodamnia cinerea</i>	Myrtaceae	+	+
174	Rubsp1	<i>Rubiaceae</i> sp.	Rubiaceae	+	+
175	Rypcae	<i>Ryparosa caesia</i>	Flacourtiaceae	+	+
176	Rypmul	<i>Ryparosa multinervosa</i>	Flacourtiaceae	+	-
177	Sabsp1	<i>Sabiaceae</i> sp.	Sabiaceae	+	-
178	Sancon	<i>Santiria converta</i>	Burseraceae	+	+
179	Sangri	<i>Santiria griffithii</i>	Burseraceae	+	+
180	Sanlae	<i>Santiria laevigata</i>	Burseraceae	+	+
181	Sanner	<i>Santiria nervosa</i>	Burseraceae	+	+
182	Sanobl	<i>Santiria oblongifolia</i>	Burseraceae	+	-
183	Santom	<i>Santiria tomentosa</i>	Burseraceae	+	+
184	Sargri	<i>Sarcotheca griffithii</i>	Oxalidaceae	+	+
185	Scamac	<i>Scaphium macropodium</i>	Sterculiaceae	+	+
186	Scubru	<i>Scutinanthe brunnea</i>	Burseraceae	+	-
187	Shoacu	<i>Shorea acuminata</i>	Dipterocarpaceae	+	+
188	Shobra	<i>Shorea bracteolata</i>	Dipterocarpaceae	+	-
189	Shodas	<i>Shorea dasyphylla</i>	Dipterocarpaceae	+	+
190	Sholep	<i>Shorea leprosula</i>	Dipterocarpaceae	+	+
191	Shoova1	<i>Shorea ovalis</i>	Dipterocarpaceae	+	+
192	Shopar	<i>Shorea parvifolia</i>	Dipterocarpaceae	+	+
193	Shopla	<i>Shorea platyclados</i>	Dipterocarpaceae	+	+
194	Sinlei	<i>Sindora leiocarpa</i>	Caesalpiniaceae	+	+

No.	FHM ID	Species	Family	10-19.9 cm	20 cm up
195	Sinvel	<i>Sindora velutina</i>	Caesalpinaceae	+	-
196	Sinwal	<i>Sindora wallichii</i>	Caesalpinaceae	+	-
197	Strzey	<i>Strombosia zeylanica</i>	Oleaceae	+	+
198	Symcoc	<i>Symplocos cochinchinensis</i>	Symplocaceae	+	-
199	Talsin	<i>Talauma singapurensis</i>	Magnoliaceae	+	-
200	Terfoe	<i>Terminalia foetidissima</i>	Combretaceae	+	+
201	Teycor	<i>Teysmanniodendron coriaceum</i>	Verbenaceae	+	+
202	Timsp1	<i>Timonius</i> sp.	Rubiaceae	+	-
203	Trihyp	<i>Trigoniastum hypoleucom</i>	Trigoniaceae	+	+
204	Trimal	<i>Trigonopleura malayana</i>	Euphorbiaceae	+	+
205	Trisp1	<i>Tricalysia</i> sp.	Rubiaceae	+	+
206	Triwhi	<i>Tristaniopsis whiteana</i>	Myrtaceae	+	+
207	Urascu	<i>Urandra scundiflora</i>	Icacinaceae	+	-
208	Witatr	<i>Witfordiodendron atropurpureum</i>	Papilionaceae	+	+
209	Xanhet	<i>Xanthophyllum heteropleurum</i>	Polygalaceae	+	+
210	Xansco	<i>Xanthophyllum scortechinii</i>	Polygalaceae	+	-
211	Xansp1	<i>Xanthophyllum</i> sp.	Polygalaceae	+	+
212	Xanvit	<i>Xanthophyllum vitellinum</i>	Polygalaceae	+	+
213	Xylalt	<i>Xylopiopsis altissima</i>	Annonaceae	+	-
214	Xylcau	<i>Xylopiopsis caudata</i>	Annonaceae	+	-
215	Xylmal	<i>Xylopiopsis malayana</i>	Annonaceae	+	+

Annex 2. List of tree species and its diameter class on MSA plots, Pulau Laut

No.	FHM ID	Species	Family	10-19.9 cm	20 cm up
1	Antchi	<i>Anthocephalus chinensis</i>	Rubiaceae	-	+
2	Artela	<i>Artocarpus elasticus</i>	Moraceae	-	+
3	Beiwig	<i>Beilschmiedia wightii</i>	Lauraceae	+	-
4	Bhepan	<i>Bhesa paniculata</i>	Celastraceae	-	+
5	Canodo	<i>Cananga odorata</i>	Annonaceae	-	+
6	Diocur	<i>Diospyros curraniopsis</i>	Ebenaceae	-	+
7	Diomac	<i>Diospyros macrophylla</i>	Ebenaceae	+	+
8	Dioper	<i>Diospyros perfida</i>	Dipterocarpaceae	-	+
9	Dipcau	<i>Dipterocarpus caudiferus</i>	Dipterocarpaceae	+	+
10	Dipgra	<i>Dipterocarpus gracilis</i>	Dipterocarpaceae	-	+
11	Diphas	<i>Dipterocarpus hasseltii</i>	Dipterocarpaceae	+	-
12	Dradao	<i>Dracontomelon dao</i>	Anacardiaceae	-	+
13	Euszwa	<i>Eusideroxylon zwageri</i>	Lauraceae	+	+
14	Homfoe	<i>Homalium foetidum</i>	Flacourtiaceae	-	+
15	Knelau	<i>Knema laurina</i>	Myristicaceae	-	+
16	Litrox	<i>Litsea roxburghii</i>	Lauraceae	+	+
17	Lopsp1	<i>Lophopetalum</i> sp.	Celastraceae	+	-
18	Mactri	<i>Macaranga triloba</i>	Euphorbiaceae	+	-
19	Octsum	<i>Octomeles sumatrana</i>	Datisceae	-	+
20	Parxer	<i>Paranephelium xertophyllum</i>	Sapindaceae	-	+
21	Parkun	<i>Parinari kuntleri</i>	Rosaceae	-	+
22	Shoova	<i>Shorea ovalis</i>	Dipterocarpaceae	-	+
23	Shopol	<i>Shorea polyandra</i>	Dipterocarpaceae	+	+





# A STUDY OF SOIL AND VEGETATION DOMINATED BY *Shorea polyandra* ON FOREST HEALTH MONITORING PLOTS IN PULAU LAUT

Technical Report No. 26

Chairil Anwar Siregar  
Supriyanto

## ABSTRACT

*Shorea polyandra*, one of the important merchantable trees, is being excessively logged either legally or illegally in Pulau Laut, South Kalimantan, these days. The work described in this paper was carried out with the objective of analyzing some important soil-related characteristics with reference to *S. polyandra* vegetation occurring at altitude ranging from lowland to upland forest through the implementation of forest health monitoring plots established in plantation forest, production forest, and protection forest in Pulau Laut. The trend of soil reaction was altered toward more acidic over time. The decrease in soil organic carbon and total nitrogen were also apparent. Soil pH and soil organic carbon decreased with the decrease in topographical position in most cases. The decrease in soil pH and soil organic carbon as well may also be due to changes in management regime of the study site in which cluster 2 vegetation was still covered by relatively dense *Shorea* trees, while the vegetation existing in cluster 1 was logged over area (logged in 1978), and cluster 3 was a 25-year old *Shorea polyandra* plantation. The difference in solum thickness, genetic part of the soil, among the three representatives of soil profile is obvious in which the solum thickness was least on high altitude and on steep slopes as it occurred in Cluster 2. It turned out to be thicker in lower altitude as it occurred in clusters 1 and 3 successively. In 1996, *Shorea polyandra* appeared to be dominant in Clusters 1, 2, 3, and 7, meanwhile *D. caudiferus* turned out to be relatively dominant in clusters 4, 5, and 6. In 2000, however, distribution of *S. polyandra* tremendously decreased and remained to be dominant in Clusters 1, 2, 3, and 7.

**Key words** : *Shorea polyandra*, soil organic carbon, logged over area

## I. INTRODUCTION

Site quality is one of the indicator studied in FHM to monitor the sustainability of Indonesian tropical rain forest. Site quality is related closely to the process of soil formation and development. The status, change and trends of site quality can be affected by the human activities and natural stressors. The process of soil formation and development of associated forest vegetation has naturally occurred hand in hand under the influence of other critical factors including climate, topography and parent material. The phenomenon is unequivocally not a simple and straightforward one, and has emerged over many thousands of years through a succession of intricate and interrelated events. In an undisturbed natural forest, the nutrient cycle of soil-vegetation is closed and the system is said to be in a steady state. Disturbances toward the closed nutrient cycle system will cause nutrient leak and end up with environmental problem. Today,

deforestation is apparently one of the most critical global ecological problems that has a bearing on sustainability, loss of genetic resources and biodiversity, soil disturbance, and affect vegetation and water resources.

Soil erosion is a ubiquitous, naturally occurring process in which weathered material is removed from the landscape. It includes the process of sediment entrainment and relocation, causing to lowering of the earth surface. However, the global distribution of erosion is becoming more serious where anthropogenic disturbances have occurred. Deforestation, especially in steep slope forested areas all give rise to accelerated soil erosion. In turn, this can lead to a diversity of environmental problems such as a decline in land productivity, excessive siltation of drainage systems, and dune encroachment that will, in turn, result in the formation of devastated land.

*Shorea polyandra*, one of the important merchantable trees, is being excessively logged either legally or illegally in Pulau Laut, South Kalimantan this day. The natural distribution of this species is spread over Ulu Kapuas, Sarawak, Southeast Sabah, Southeast Borneo to Pulau Laut and Meratus mountains. In Pulau Laut, this meranti putih (yellow or white meranti) is locally abundant on fertile clay rich soils on calcareous shales, igneous and volcanic rocks at altitude up to 600 m above sea level. The adverse effect of logging is becoming severe especially when the natural *S. polyandra* grown on areas with topography wavy to dissected and the soils outcropping is Inceptisols bearing solum thickness less than 50 cm over hard bed rock.

Landscape ecology, whose argument rests on ecological and morphological theories, is available as an attempt to produce useful frameworks for management (Godron and Forman, 1983). Most researchers indicated that landscape components that favour K-selected species are the upper slopes of drainage basins, as in the case of up land forest dominated by *S. polyandra* in Pulau Laut. This K-Landscape can develop ecosystems with strong biotic controls and interrelationships between species; and under disturbance by a new force or process it may take centuries to recover its former equilibrium pattern.

The work described in this paper was carried out with the object of analyzing some important soil related characteristics with reference to *S. polyandra* vegetation occurring at altitude ranging from low land to up land forest through the implementation of forest health monitoring plots established in plantation forest, production forest, and protection forest, in Pulau Laut.

## II. MATERIALS AND METHODS

### 2.1. Location

The forest health monitoring plots associated with soil indicator and vegetation study was carried out in concession areas of P.T. INHUTANI II in South Kalimantan from 1996 to 2000. General information of the FHM study site is provided as follows.

P.T. INHUTANI II is located in Pulau Laut, a small island that belongs to South Kalimantan Province. The FHM plots were established in Buffer Zone, which was logged in 1978 (cluster 1 and 7), Biodiversity Conservation Area (cluster 2), Dipterocarp Plantation (cluster 3) and Seed Production Areas (cluster 4, 5, and 6). The soil order falls into Oxisols, and Inceptisols, topographical condition ranging from flat to hilly and dissected with slope greater than 50 %. Some important physical and chemical nature of the soil are moderately fine (topsoil) and fine (subsoil), shallow to very shallow, high exchangeable Ca and Mg, medium to high exchangeable K, low exchangeable Na, low to medium CEC, acid to slightly acid, and low Al saturation.

Based on the criteria of Schmidt and Ferguson, the climate in the project site is categorized into Type A with annual rainfall ranges from 2429 to 2492 mm. The rainy season occurs on December to June with monthly rainfall average of more than 250 mm, meanwhile the dry season occurs on July to November with monthly rainfall average of 150 mm.

#### 2.1.1. Location of sampling points

Plot establishment procedure, described by USDA Forest Service (1999), was applied on each cluster under investigation. Soil sampling sites are located on soil sampling lines adjacent to subplots 2,3, and 4 on the FHM plot (Figure 1). The location of a soil sampling site on the soil sampling line is determined by the number of times a plot has previously been sampled. The forest floor layers (litter layer and organic soil layer – if present) are sampled at only one soil sampling site on each plot. The primary location is the soil sampling site associated with subplot 2. If no litter layer is found at the sampling site on subplot 2, proceed to subplot 3. Proceed to subplot 4 if necessary.

Mineral soil samples are taken from three soil sampling sites and composite by depth layers into individual soil samples for analysis. Locate the three soil sampling sites using the following procedure:

- From the center of Subplot 2 of the FHM plot, measure 30 ft (9.2 m) on an azimuth of 180 degrees or due south. Mark the soil sampling site with flagging. This is soil sampling site for visit # 1 to the subplot 2 soil sampling line.

From the center of Subplot 3 of the FHM plot, measure 30 ft (9.2 m) on an azimuth of 300 degrees (northwest). Mark the soil sampling site with flagging. This is soil

sampling site for visit number 1 to the subplot 3 soil sampling line. Mineral soil samples are taken from three soil sampling sites and composite by depth layers into individual soil samples for analysis.

- From the center of Subplot 4 of the FHM plot, measure 30 ft (9.2 m) on an azimuth of 60 degrees (northeast). Mark the soil sampling site with flagging. This is soil sampling site for visit number 1 to the subplot 4 soil sampling line.

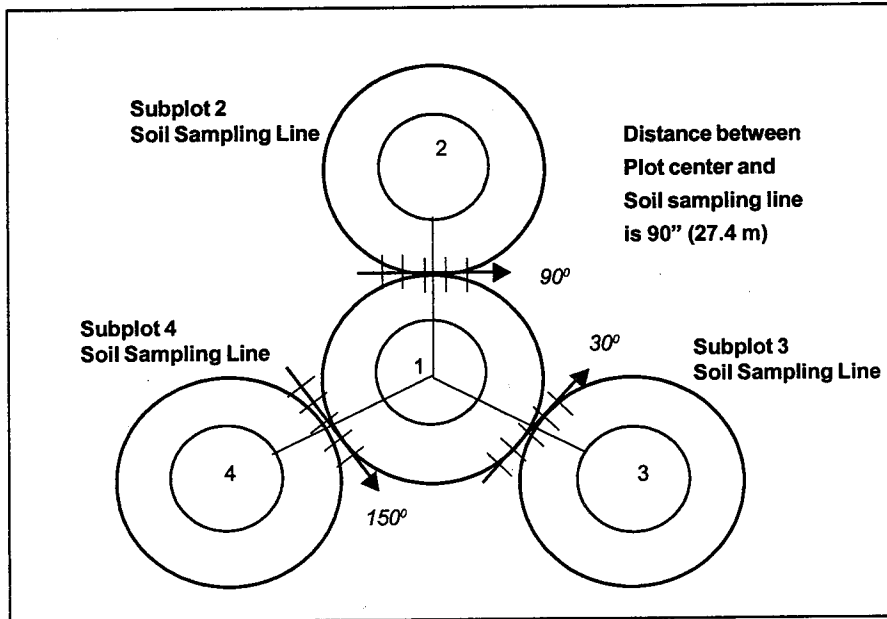

Figure 1. Location of soil sampling lines

During the first visit to a plot for soil sampling, soil sampling site with visit number 1 will be used for soil depth measurements and to collect soil samples. On subsequent visit to a plot, soil sampling sites of numbers 2 or larger will be used (depending on the number of times a plot has previously been sampled).

Proceed to the location of the appropriate sampling site along a soil sampling line. If it appears that a soil sample can be taken, place a small plastic tarp on the ground beside the sampling point.

## 2.2. Measuring and Sampling Procedures

### 2.2.1. Organic Layers

Proceed to sampling point 1. Place a plastic tarp on the ground beside the sampling point. Sample the organic surface material as follows. Place a sampling frame

of known area (e.g., 0.3 m<sup>2</sup>) over the sampling point. Using a sharp knife, carefully cut through the organic soil surface along the inner surface on the frame to separate it from the surrounding soil. Carefully remove any live forbs, grasses or shrubs and all living aboveground vegetation from the sample area. Using inward scooping motions, carefully remove the entire volume of O horizon material from within the confines of the sampling frame. Working over the tarp, place the entire O horizon sample into a pre-labeled 8-L sample bag. In some areas more than one bag might be required to hold the sample. If so, label the bags with identical information, then add "1 of 2" and "2 of 2" respectively. Make sure the bag is properly labeled and then seal it securely. The O horizon is sampled only at sampling point 1.

Measure the thickness of the O horizon to the nearest cm at four points on the outer perimeter of the sampled area. Locate these points due north, due east, due south and due west. Determine the mean of the four measurements and record it.

### **2.2.2. Mineral Surface Layers**

After exposing the top of the mineral surface layer (A horizon) by removing the O horizon, use a tile spade or entrenching tool to excavate a soil pit approximately 30 cm on a side and deep enough to expose the boundary between the soil surface and the subsoil. Do not excavate deeper than 50 cm. Record the thickness of the A horizon (lighter texture; colored brownish from organic material leached in from O horizon) and the depth to the subsoil (usually the "B" horizon; generally heavier textured and brighter yellow or red color) to the nearest cm. Measure the A horizon thickness and the depth to the subsoil at the four points on the outer perimeter of the sampled area. Locate these points due north, due east, due south, and due west. Determine the means of each set of four measurements and record them. If the subsoil is not encountered within a depth of 50 cm, record depth to the subsoil as "more than 50 cm."

Smooth and clean one face of the pit for sampling. Measure from the surface of the mineral soil to the bottom of the A horizon and mark the boundary with a knife. Then measure 10 cm below the bottom of the A horizon (often the "E" horizon; similar texture to A but without organic material leached in) and mark this boundary. Remove approximately 150 cc (about 2 handfuls) of soil from the A horizon and place it in a pre-labeled 2-L sample bag. Then remove approximately 150 cc of soil from the underlying 10 cm layer and place it in a second 2-L sample bag. Estimate the texture of the second layer and record it as loamy, clayey or sandy. If possible, discard rock fragments larger than approximately 20 mm (3/4 in) in diameter (coarse pebbles or larger) from all soil samples. Discard root fragments also.

After sampling and measurements are completed, place the soil back in the pit in its original layer sequence. Try to restore the sample point as similar to its original condition as possible. Proceed to sampling point 2.

At sampling point 2, lay the tarp down beside the area to be sampled. Remove the organic surface layer and place it on the tarp, but do not sample it. Prepare a sampling pit as before. Sample the A horizon, placing approximately 150 cc of soil into the same 2-L bag containing the A horizon sample from point 1. Shake the bag to mix the samples. Then sample the underlying 10 cm layer as before, placing approximately 150 cc of soil in the same 2-L bag containing the second mineral sample from point number 1. Shake the bag to mix the samples. Estimate the texture of both the A horizon and the underlying 10 cm layer, recording texture as clayey, loamy or sandy. As before, record the thickness of the A horizon and the depth to the subsoil to the nearest cm. If the subsoil is not encountered within a depth of 50 cm, record depth to the subsoil as "more than 50 cm".

After restoring the site at sampling point 2, proceed to sampling point 3. Repeat the procedure followed at sampling point 2. Seal the sample bags and make sure they are properly labeled with the state, hex number, layer sampled, date, and crew identification.

In addition to the soil sampling procedure as described by USDA Forest Service (1999) and to further define the soil characterization, three representative soil profiles were made namely one in cluster 1 representing middle topographical position (250 m asl.), one in cluster 2 representing higher topographical position (600 m asl.), and one soil pit in cluster 3 representing lower topographical position (40 m asl.).

Vegetation structure study was carried out as described by USDA Forest Service (1999) with modification. Quadrat layout of 1 m x 1 m was employed to identify understory vegetation. Quadrats were established 4.57 m from each subplot center along 30°, 150°, and 270° azimuths. Identification of sapling (diameter 2.5-9.9 cm), and pole (diameter 10-19.9 cm) were done in the subplot of each cluster. Meanwhile the identification of nucleus and mature trees were executed from the center of subplot to the annular plot.

### **2.3. Laboratory Analyses**

Soil samples collected from the field are analyzed in the laboratory to determine the following:

- Mineral soil samples:

- |                                  |                      |
|----------------------------------|----------------------|
| - pH in water and in KCl         | - Bray I Phosphorus  |
| - Total organic carbon           | - CEC and BS         |
| - Exchangeable Ca, Mg, K, and Na | - Texture (optional) |

- Organic layers:
  - Total organic carbon
  - Total N
  - Percent organic matter (Loss on ignition, LOI)

### III. RESULTS AND DISCUSSIONS

#### 3.1. Soil Chemical and Physical Characteristics

Summary of status and changes in important soil chemical properties of Pulau Laut study site year 1996, 1999, and 2000 are presented in Table 1. Trend of soil reaction was altered toward more acidic over time. The decrease in soil organic carbon and total nitrogen were also apparent. Note also that the depletion of soil organic matter content is consistent with considerable decrease of exchangeable bases, particularly Ca, and Bray I extractable P. Generally, the status of soil chemical properties decreased with soil depth, however, considerable random variations within time of observation was evident. Soil texture of this site is classified into clay, and in most cases the accumulation of clay particle is detected on the lower soil layer (B horizon).

Soil pH and soil organic carbon decreased with the decrease in topographical position in most cases. The decrease in soil pH and soil organic carbon as well may also be due to changes in management regime of the study site in which cluster 2 vegetation was still covered by relatively dense shorea trees, while the vegetation existed in cluster 1 was logged over area (logged in 1978), and cluster 3 was a 25 year old *Shorea polyandra* plantation. Forest soils seldom are either wholly hydrogen or wholly base saturated and consequently show reaction values intermediate between the two extremes. Figure 1 shows schematic topographical position of FHM cluster plots in Pulau Laut.

Leaching is the primary cause of removal bases and the consequent development of acidity. If that is the case, the decrease in soil pH with the decrease in altitude may be depicted as severe driving force occurred in lower altitude resulted from forest degradation as indicated by canopy gap forming process.

As a result of the natural driving force, rocks and minerals exposed at the surface of the earth are transformed into soil in the course of time. The rate of transformation and the features of the soil which ultimately results vary with the nature of the environment and the parent rocks and minerals. Consequently, various soils are encountered even in regions that are climatically uniform, and hence soils may be differing tremendously as a result of variations in surface geology. Relief affects soil development through its influence on water relations, erosion, temperature regimes, and vegetation cover. In this

observation, the influence of relief was expressed mainly in the depth of soil and its organic litter and hence the cation exchange capacity (CEC) as from 20 to 70 % of the CEC of many soils is caused by the functional groups of organic matter. Note the difference in solum thickness, genetic part of the soil, among the three representatives of soil profile (Table 2, Fig. 2). The solum thickness was least on high altitude and on steep slopes as it occurred in Cluster 2.

One of the most important soils forming process in forest areas is podzolization, and is generally applied to the process by which organic materials and sesquioxides are translocated from the upper soil horizon and subsequently deposited in the B horizon. This process hence, leads to depletion of bases, development of acidity, and formation of eluvial A horizon and illuvial B horizon in soils. Areas where podzolization is the dominant soil forming process are characterized by a relatively cool, humid climate and forest vegetation. The process operates with varying intensity in tropical climate wherever rainfall is sufficient to induce water percolation through soils having acid organic matter. It is active in soils supporting hardwoods, as well as in those supporting conifers.



Table 1. Soil chemical properties of Pulau Laut, 1996, 1999 and 2000

Location, Year	Cluster	Hor.	pH		C.org	N tot	LOI	C / N	Ca	Mg	Na	K	P	CEC	BS	Al	H	Sand	Silt	Clay
			H <sub>2</sub> O	KCl																
P. Laut, 1996	1	A	7.1	6.9	4.70	0.69	-	6.81	24.83	9.98	-	0.89	31.11	-	-	-	-	-	-	-
P. Laut, 1996	1	B	7.0	6.1	4.10	0.61	-	6.72	12.69	5.17	-	0.98	7.34	-	-	-	-	-	-	-
P. Laut, 1996	2	A	7.4	7.1	5.40	0.82	-	6.59	34.69	7.81	-	0.93	44.68	-	-	-	-	-	-	-
P. Laut, 1996	2	B	7.0	6.4	3.50	0.50	-	7.00	20.95	3.28	-	0.54	28.12	-	-	-	-	-	-	-
P. Laut, 1996	3	A	6.5	5.0	4.45	0.67	-	6.64	20.19	6.58	-	0.96	24.60	-	-	-	-	-	-	-
P. Laut, 1996	3	B	5.2	5.6	1.70	0.25	-	6.80	3.26	1.54	-	0.24	25.42	-	-	-	-	-	-	-
P. Laut, 1996	4	A	6.7	4.0	2.00	0.30	-	6.67	9.19	2.59	-	0.42	20.40	-	-	-	-	-	-	-
P. Laut, 1996	4	B	5.3	5.4	1.15	0.16	-	7.19	1.84	1.03	-	0.14	2.47	-	-	-	-	-	-	-
P. Laut, 1996	5	A	6.5	5.4	4.35	0.77	-	5.65	9.80	5.68	-	1.17	12.65	-	-	-	-	-	-	-
P. Laut, 1996	5	B	4.5	3.5	1.05	0.16	-	6.56	0.92	0.93	-	0.40	20.61	-	-	-	-	-	-	-
P. Laut, 1996	6	A	6.9	5.8	3.40	0.52	-	6.54	6.18	3.64	-	0.66	10.99	-	-	-	-	-	-	-
P. Laut, 1996	6	B	4.6	3.6	1.00	0.14	-	7.14	1.37	0.65	-	0.16	18.80	-	-	-	-	-	-	-
P. Laut, 1996	7	A	7.3	6.4	3.85	0.67	-	5.75	28.19	10.09	-	1.07	42.96	-	-	-	-	-	-	-
P. Laut, 1996	7	B	6.3	5.1	1.15	0.18	-	6.39	7.80	4.21	-	0.60	24.04	-	-	-	-	-	-	-

Remark: - data not available

Table 1. (Continuation)

Location, Year	Cluster	Hor.	pH		C org	N tot	LOI	C / N	Ca	Mg	Na	K	P	CEC	BS	Al	H	Sand	Silt	Clay
			H <sub>2</sub> O	KCl																
P. Laut, 1999	1	A	5.2	4.5	3.84	0.33	11.64	18.99	2.80	3.64	0.22	0.55	8.09	21.24	33.95	0.19	0.12	13.76	38.32	47.92
P. Laut, 1999	1	B	5.2	4.1	1.55	0.16	10.33	15.56	2.32	3.34	0.22	0.48	5.69	18.11	35.12	0.06	0.16	17.53	27.59	54.88
P. Laut, 1999	2	A	6.5	5.7	3.70	0.35	10.59	9.27	8.15	4.26	0.20	0.58	5.31	16.65	79.23	0.23	0.01	22.72	30.03	47.25
P. Laut, 1999	2	B	6.2	5.4	1.67	0.20	8.24	9.70	4.06	3.30	0.12	0.53	3.93	10.90	73.46	0.18	0.01	25.41	30.06	44.53
P. Laut, 1999	3	A	5.6	4.8	3.50	0.33	10.76	15.89	5.90	6.42	0.62	0.72	7.17	23.37	58.46	0.06	0.01	21.65	33.42	44.93
P. Laut, 1999	3	B	4.7	4.2	1.49	0.15	9.93	15.64	2.13	2.34	0.20	0.34	6.83	17.01	29.45	0.43	0.03	18.07	31.54	50.39
P. Laut, 1999	4	O	6.7	6.0	22.46	1.09	20.54	41.10	10.62	12.42	1.68	5.17	21.98	37.47	79.77	0.53	0.25	6.24	31.63	62.13
P. Laut, 1999	4	A	5.6	5.5	3.13	0.26	12.04	12.05	2.22	3.54	0.22	1.18	5.18	9.30	77.01	0.36	0.18	11.62	21.23	67.15
P. Laut, 1999	4	B	5.2	4.5	1.17	0.13	9.22	8.15	0.73	1.52	0.29	1.06	3.79	6.50	55.39	2.39	0.88	5.36	20.44	74.20
P. Laut, 1999	5	A	5.2	4.9	2.15	0.18	11.68	11.18	1.56	2.74	0.42	1.12	6.32	7.55	77.37	2.12	0.39	4.99	26.69	68.32
P. Laut, 1999	5	B	4.2	4.7	1.09	0.11	9.53	6.61	0.24	0.64	0.11	0.43	1.43	6.49	21.43	3.97	1.06	19.10	32.68	48.22
P. Laut, 1999	6	A	5.3	4.7	2.37	0.24	9.88	10.29	1.18	1.18	0.34	0.62	6.55	6.26	67.89	2.53	1.20	14.49	33.14	52.37
P. Laut, 1999	6	B	4.8	4.5	1.79	0.18	9.93	6.02	0.36	0.36	0.28	0.38	5.30	3.52	48.01	1.78	0.65	2.58	25.54	71.89
P. Laut, 1999	7	A	5.7	5.2	3.58	0.30	11.95	19.96	4.06	3.34	1.09	0.53	16.35	18.63	48.42	0.13	0.03	16.41	36.34	47.52
P. Laut, 1999	7	B	4.9	4.5	2.16	0.22	9.82	14.80	2.99	5.03	0.17	0.50	10.15	19.70	44.11	0.33	0.02	12.91	31.61	55.48

Table 1. (Continuation)

Location, Year	Cluster	Hor.	pH		C org	N tot	LOI	C / N	Ca	Mg	Na	K	P	CEC	BS	Al	H	Sand	Silt	Clay
			H <sub>2</sub> O	KCl																
P. Laut, 2000	1	A	4.5	4.2	2.61	0.22	9.70	11.86	0.70	1.79	0.33	1.21	8.1	17.72	22.74	3.4	0.6	-	-	-
P. Laut, 2000	1	B	4.5	4.1	1.00	0.07	5.72	14.29	0.27	1.31	0.20	2.14	13.90	8.40	46.67	0.9	0.2	-	-	-
P. Laut, 2000	2	A	6.2	5.8	7.04	0.37	15.32	19.03	0.82	2.11	0.24	8.45	22.91	28.71	40.47	0.5	0.1	-	-	-
P. Laut, 2000	2	B	6.4	5.5	1.27	0.15	7.18	8.47	0.64	2.07	0.19	4.28	16.3	9.33	76.96	0.3	0.1	-	-	-
P. Laut, 2000	3	A	4.3	4.0	2.39	0.27	9.30	8.85	0.85	1.12	0.60	1.41	9.9	12.47	31.92	3.3	0.4	-	-	-
P. Laut, 2000	3	B	4.2	3.7	0.64	0.08	3.22	8.00	0.28	0.33	0.22	0.53	20.9	6.41	21.22	3.5	0.2	-	-	-
P. Laut, 2000	4	A	4.6	4.0	2.28	0.20	9.56	11.40	0.69	2.03	0.62	1.31	8.7	10.34	44.97	2.6	0.2	-	-	-
P. Laut, 2000	4	B	4.2	4.0	1.30	0.13	7.47	10.00	0.36	1.30	0.37	0.61	11.7	6.01	43.93	6.4	0.5	-	-	-
P. Laut, 2000	5	A	4.0	3.6	1.79	0.16	8.94	11.19	0.40	0.96	0.21	0.17	7.1	9.30	18.71	7.2	0.3	-	-	-
P. Laut, 2000	5	B	4.0	3.5	1.10	0.10	6.89	11.00	0.62	1.42	0.21	0.89	4.1	7.96	39.45	7.6	0.1	-	-	-
P. Laut, 2000	6	A	4.1	3.6	1.58	0.10	10.49	15.80	0.63	0.82	0.57	0.94	13.3	7.56	39.15	4.6	0.7	-	-	-
P. Laut, 2000	6	B	3.9	3.4	0.82	0.09	5.41	9.11	0.49	0.39	0.26	0.33	17.3	6.29	23.37	4.5	0.8	-	-	-

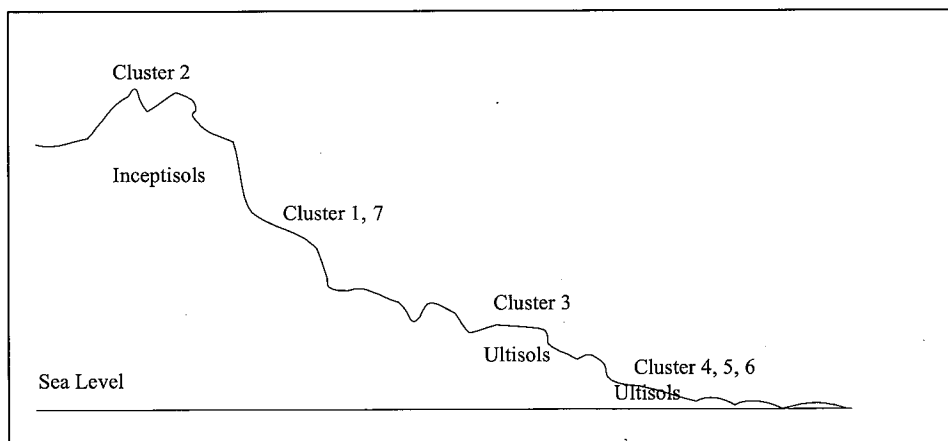

Fig. 2. Schematic topographical position of FHM cluster plots in Pulau Laut

Table 2. Soil profile descriptions of cluster 1, 2, and 3

Cluster	Horizon	Description
1	A : 0-20 cm	10 YR 5/4, clay, weak medium granular structure, strongly acid, abundant medium to coarse roots, clear wavy boundary.
	B : 20-100 cm	5 YR 5/6, stony, clay, strong medium angular blocky structure, strongly acid, common medium to coarse roots.
2	A : 0 18 cm	10 YR 2/2, clay, weak medium granular structure, acid, abundant medium to coarse roots, gradual wavy boundary.
	BW : 18 36 cm	7.5 YR 5/4, stony, clay, well medium angular blocky structure, acid, common medium to coarse roots.
3	A : 0 20 cm	7.5 YR 4/4, clay, weak medium granular structure, strongly acid, abundant medium to coarse roots, diffuse wavy boundary.
	AB : 20-38 cm	5 YR 4/4, clay, well medium angular blocky structure, strongly acid, common medium to coarse roots, diffuse wavy boundary.
	B : 38-89 cm	5 YR 5/6, clay, strongly acid, strong medium subangular blocky structure, few medium roots, diffuse wavy boundary.
	C : 89-142 cm	5 YR 6/6, stony, clay



(a)



(b)



(c)

Fig. 3. Vertical cut of soil profile from cluster 1 (a), cluster 2 (b), and cluster 3 (c)

Under forest conditions soil profiles characteristically have a layer of acid organic matter on the surface of mineral soil. The tree leaves and other organic litters reaching the soils are relatively poor in bases, and on decomposition process, principally by fungi, the organic litters give rise to acid products. When the acids generated in the organic layers are move downward through percolating water, they encounter the soil minerals, leach out exchangeable cation like Ca, and Mg, and generally decrease the pH of the mineral soil. Further, the acid weathering of the soil minerals causes a significant loss of metallic cations, including Fe and Al, but most of silica remains behind. Unlike the other minerals, quartz is particularly resistant to attack by acid solutions, and may accumulate in the soil's sand and silt fraction (Tan, 1994; Bohn et al., 1985). Accordingly, its relative proportion in the A horizon increases as leaching occurs. Note that relative proportion of sand and silt sized particles are roughly higher in the A horizon than that of in B horizon (Table 2).

The other important soils forming process in forest areas is laterization, and is generally characterized by humid tropical climates and a hardwood forest. This process favors the formation of red–yellow podzolic soils or Ultisols and Oxisols rich in kaolinite and sesquioxides (Tan, 1994). Under these conditions chemical weathering is very profound. Soil minerals and the parent rocks are subjected to extremely strong hydrolysis and oxidation, with the release of bases and the production of silicic acid and hydrated oxides of Al and Fe. In the initial phases of the genesis of laterites there is a rapid liberation of bases such as Ca, Mg, K, Na, resulting in nearly neutral or alkaline conditions in the upper soil layers. This initial condition of low acidity, or alkalinity, is retained to be further favored by the absorption and return to the surface by plants of at least a part of the liberated bases. Rapid decomposition of the organic matter results in the release of the contained bases. With the reaction nearly neutral or alkaline, solution and removal of silica from the silicate minerals is favored. Fe, Al, and Mn oxidize and are left behind, together with the quartz-silica.

The forest floor is not only a source of food and habitat for many microflora and fauna, but the continuing additions of litter to the floor represent a revolving fund of nutrients, mainly N, P, and S for higher plants. Three layers or strata, of the forest floor are commonly recognized. The most upper layer is organic litter layer consisting of unaltered dead remains of plants and animals, and is considered part of the forest floor, but not part of the humus layer. Layer immediately below the litter layer consisting of fragmented, partly decomposed organic matter that are sufficiently well preserved to permit identification as to origin. The lower humus layer, consists largely of well decomposed, amorphous organic matter. At least two types of humus layers are recognized regarding the origin of the distinctive features namely mor and mull humus

types. Mor humus is superficial deposit of organic remains, compacted and sharply delineated from the mineral soil below, while mull humus is the intricate mixture of amorphous humus and mineral soil, possessed a diffuse lower boundary and a crumblike or a granular structure. Further, mulls are generally less acid than mors and consequently, bacteria are more abundant in mulls, while fungi are the most important microorganisms in the mor humus type. Mull humus types are usually formed under hardwood forests growing on soils well supplied with bases, while mor types are most often found under coniferous forest growing on spodic soils.

In addition to leaching, primary cause of removal bases and the consequent development of acidity, the development of vegetation on earth surface in the course of time can also result in the development of soil acidity. Both softwood (gymnosperm) and hardwood (angiosperm) trees tend to acidify the soil reaction since proton production due to nutrient uptake and storage exceeds proton consumption due to mineral weathering, mineralization of organic matter, and nitrogen fixation in the soil (Ponge et al., 1998). Since cations are preferentially absorbed over anions, especially when the nitrate ion is scanty, therefore the imbalance between cation and anion uptake by plant roots is a proton producing process in which proton in soil solution will replace essential bases, Ca and Mg, that are liberated in the soil solution or adsorbed on exchange sites, during mineral weathering. Moreover, as forest species grow and develop through the pole stage, which is the phase of intensive growth, moder humus develops (Ponge and Delhayé, 1995). Moder humus, gradual transition between mor and mull humus, resulting from the accumulation of organic matter in the form of feces of invertebrates is deposited at the surface of the soil profile and is strongly acidic. At this time, in-growth and development of most forest species are soil acidifiers, except those that are able to alter acidification through symbiotic nitrogen fixation, and those producing litter which decomposes at high rate. Acidifiers are associated with the moder humus because of a decrease in soil biodiversity, which results from the disappearance or strong reduction of litter and soil dwelling macro-invertebrates, particularly burrowing earthworms.

This study indicates that, in general, carbon content of the soil in descending order occurs at cluster 2 (biodiversity conservation area), followed by cluster 1, and 7 (buffer zone, but was logged in 1978), cluster 3 (25 year old *S. polyandra* plantation), and cluster 4, 5, and 6 (seed production area, but was severely encroached since 1998). The same trend is also evident for soil reaction. Low soil organic matter content may cause soil susceptible to compaction (Zhang et al., 1997) and in turn, regeneration problem.

Further, based on soil data, virtually, there is close correlation between soil carbon content and soil pH and soil C/N ratio, and this is in agreement with the observation of researchers working on soil in the tropical forest as quoted by (Noordwijk et al., 1997).

Land use type, altitude, and both can affect the soil carbon content changes. Primary tropical forests are likely bearing higher soil carbon contents than other types of vegetation and this view was in line with the assumption of a 50 % reduction in soil carbon storage (from 120 to 60 Mg ha<sup>-1</sup>) from undisturbed forest to grasslands in Southeast Asia (Palm et al., 1986). Data on spatial variability of soil carbon pools under primary forest however are scanty, and considerable variability has been reported (Noordwijk et al., 1997). In the study areas, essential diversity of soil types was evident as it occurred in different topographical position. Inceptisols, recent sedimentary soils outcrops at the piedmont, foothills of the mountain (cluster 2), and Ultisols, older sedimentary and highly leached soils occurs at the pediment penepplain (cluster 1 and 3).

The soil carbon content increase as altitude increase can be attributed to temperature decrease accordingly, in which rate of organic litter decomposition is declined. Average temperature in the country decreases by 0.6 °C per 100 m rise in elevation.

### 3.2. Dominant Vegetation Composition and Structure

In the floristic analysis, cumulative density function of Weibull distribution for diameter of *Shorea polyandra* (cluster 1, 2, 3, and 7), and other trees (cluster 4, 5, and 6) are presented in Figure 2-6. List of tree species and its distribution on each cluster based on observation conducted in 1996 and 2000 are shown in Table 3 and 4, respectively.

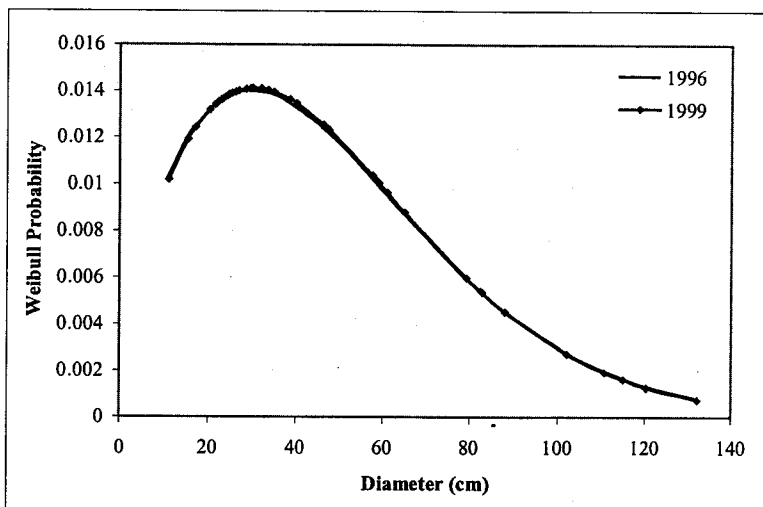

Figure 4. Probability density function of Weibull distribution for diameter of *Shorea polyandra* in cluster 1 Pulau Laut



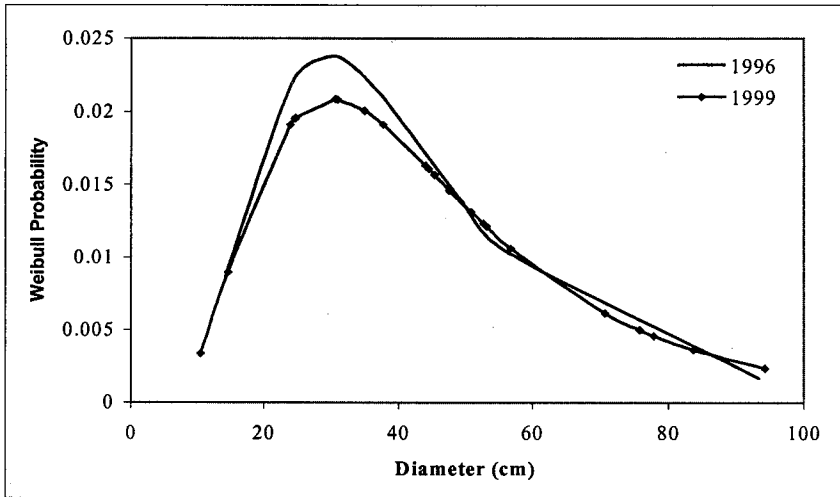

Figure 5. Probability density function of Weibull distribution for diameter of *Shorea polyandra* in cluster 2 Pulau Laut

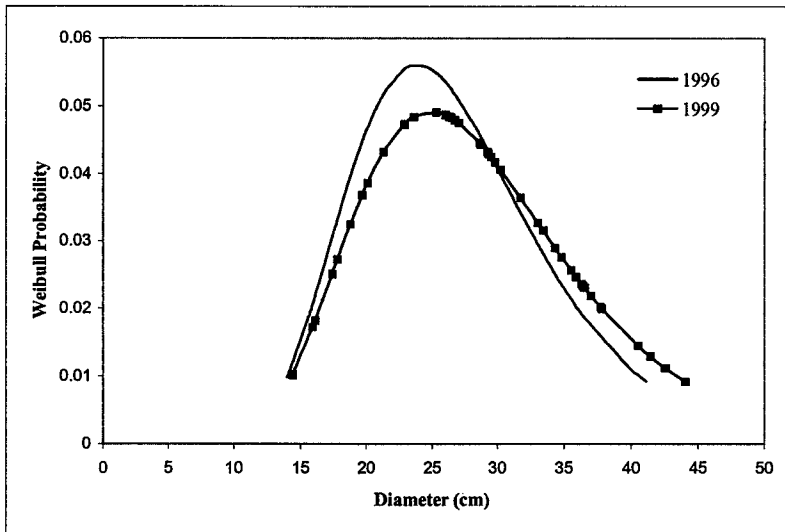

Figure 6. Probability density function of Weibull distribution for diameter of *Shorea polyandra* in cluster 3 Pulau Laut

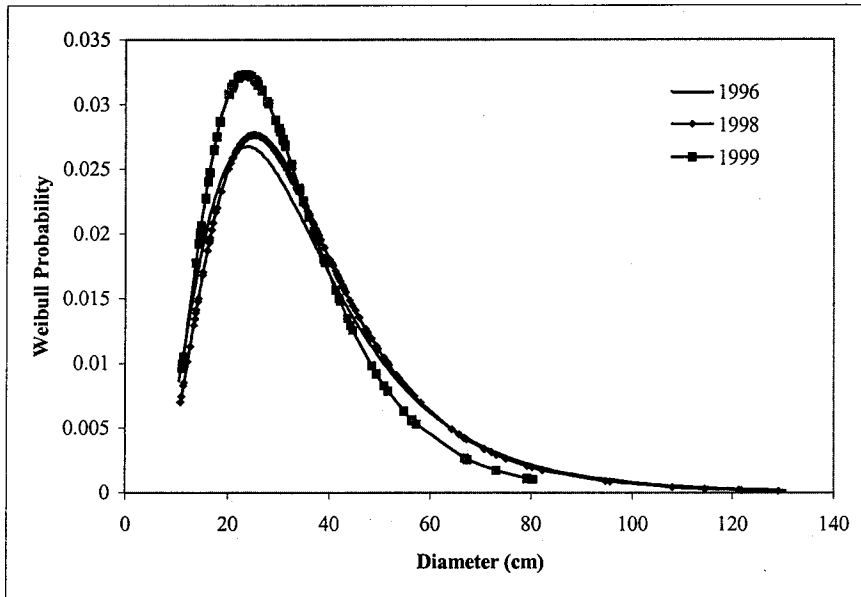

Figure 7. Probability density function of Weibull distribution for diameter of all tree species averaged across cluster 4, 5, and 6, Pulau Laut

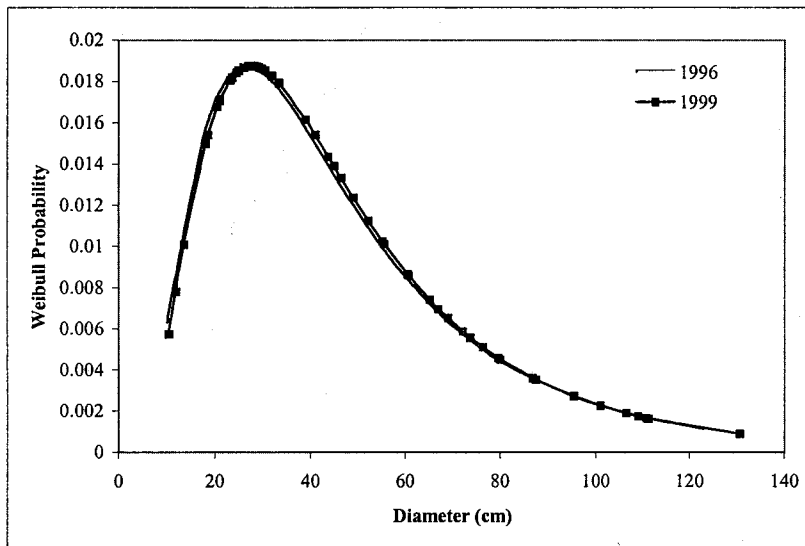

Figure 8. Probability density function of Weibull distribution for diameter of *Shorea polyandra* in cluster 7 Pulau Laut

Table 3. List of tree species and its distribution on FHM cluster-plots, Pulau Laut, year 1996

FHM ID	Species Name	Family	Number of Trees in Cluster							
			Total Trees	1	2	3	4	5	6	7
Acacat	<i>Acalypha caturus</i>	Euphorbiaceae	2		2					
Adetam	<i>Adenanthera tamarindifolia</i>	Mimosaceae	1							1
Aglgan	<i>Aglaiia ganggo</i>	Meliaceae	5				2	1	1	1
Aglodo	<i>Aglaiia odoratissima</i>	Meliaceae	1				1			
Alemol	<i>Aleurites moluccana</i>	Euphorbiaceae	2		2					
Alpjav	<i>Alphonsea javanica</i>	Annonaceae	1	1						
Alsumb	<i>Alseodaphne umbelliflora</i>	Lauraceae	2				1			1
Antchi	<i>Anthocephalus chinensis</i>	Rubiaceae	14				9			5
Aposp1	<i>Aporusa sp. 1</i>	Euphorbiaceae	2					2		
Artani	<i>Artocarpus anisophyllus</i>	Moraceae	1				1			
Artela	<i>Artocarpus elasticus</i>	Moraceae	4	1	2					1
Artrig	<i>Artocarpus rigidus</i>	Moraceae	1						1	
Artruf	<i>Artocarpus rufescens</i>	Moraceae	1						1	
Bacjav	<i>Baccaurea javanica</i>	Euphorbiaceae	1		1					
Bacsp1	<i>Baccaurea sp. 1</i>	Euphorbiaceae	1					1		
Beigig	<i>Beilschmiedia gigantocarpa</i>	Lauraceae	1		1					
Botgen	<i>Botryophora geniculata</i>	Euphorbiaceae	1		1					
Canasp	<i>Canarium asperum</i>	Burseraceae	1					1		
Canodo	<i>Cananga odorata</i>	Annonaceae	1	1						
Citsp1	<i>Citronella sp. 1</i>	Icacinaceae	1							1
Crycra	<i>Cryptocarya crassinervia</i>	Lauraceae	2				1		1	
Dacros	<i>Dacryodes rostrata</i>	Burseraceae	8				2	3	3	
Diaind	<i>Dialium indum</i>	Caesalpiniaceae	3					3		
Dilbor	<i>Dillenia borneensis</i>	Dilleniaceae	2					1	1	
Dilexc	<i>Dillenia excelsa</i>	Dilleniaceae	1						1	
Diocur	<i>Diospyros curraniopsis</i>	Ebenaceae	9		2		7			
Diomac	<i>Diospyros macrophylla</i>	Ebenaceae	18	2	7		1	2	3	3
Dipcau	<i>Dipterocarpus caudiferus</i>	Dipterocarpaceae	59		1		14	15	28	1
Dipcor	<i>Dipterocarpus cornutus</i>	Dipterocarpaceae	2				1		1	
Dracos	<i>Dracontomelon costatum</i>	Anacardiaceae	1		1					
Dradao	<i>Dracontomelon dao</i>	Anacardiaceae	2	2						
Drysp1	<i>Drypetes sp.</i>	Euphorbiaceae	6					4	2	
Duamol	<i>Duabanga moluccana</i>	Sonneratiaceae	1		1					
Duracu	<i>Durio acutifolius</i>	Bombacaceae	10				2	2	6	
Enddia	<i>Endospermum diadenum</i>	Euphorbiaceae	1		1					
Endsp1	<i>Endiandra sp. 1</i>	Lauraceae	1					1		
Eugpol	<i>Eugenia polyantha</i>	Myrtaceae	1						1	

Table 3. (Continuation)

FHM ID	Species Name	Family	Number of Trees in Cluster							
			Total Trees	1	2	3	4	5	6	7
Eugsp1	<i>Eugenia sp. 1</i>	Myrtaceae	13		1		4	4	4	
Ficsp1	<i>Ficus sp. 1</i>	Moraceae	4							4
Gimer	<i>Gironniera nervosa</i>	Ulmaceae	6	1			1	1	3	
Gluwal	<i>Gluta wallichii</i>	Anacardiaceae	7					2	5	
Homfoe	<i>Homalium foetidum</i>	Flacourtiaceae	1	1						
Hopdry	<i>Hopea dryobalanoides</i>	Dipterocarpaceae	1							1
Hopner	<i>Hopea nervosa</i>	Dipterocarpaceae	7				2	1	4	
Hopver	<i>Hopea veruginea</i>	Dipterocarpaceae	1					1		
Knelau	<i>Knema laurina</i>	Myristicaceae	3		1		1		1	
Kokoch	<i>Kokoona ochracea</i>	Celastraceae	1							1
Lapsp1	<i>Laportea sp. 1</i>	Urticaceae	12		12					
Litatr	<i>Litsea atropurpurea</i>	Lauraceae	1					1		
Litben	<i>Lithocarpus bennetti</i>	Fagaceae	4		1		1		2	
Litfir	<i>Litsea firma</i>	Lauraceae	1				1			
Litrox	<i>Litsea roxburghii</i>	Lauraceae	10	4	4					2
Litsp1	<i>Litsea sp. 1</i>	Lauraceae	3		1			1	1	
Macpru	<i>Macaranga pruinosa</i>	Euphorbiaceae	8		8					
Macsp1	<i>Macaranga sp. 1</i>	Euphorbiaceae	3				2			1
Malpen	<i>Mallotus penangensis</i>	Euphorbiaceae	3					2	1	
Mastri	<i>Mastixia trichotoma</i>	Cornaceae	1		1					
Myrine	<i>Myristica iners</i>	Myristicaceae	2		1			1		
Nauori	<i>Nauclea orientalis</i>	Rubiaceae	1				1			
Nausp1	<i>Nauclea sp. 1</i>	Rubiaceae	1					1		
Octsum	<i>Octomeles sumatrana</i>	Datiaceae	2	2						
Paldas	<i>Palaquium dasyphyllum</i>	Sapotaceae	7		1					6
Parkun	<i>Parinari kuntleri</i>	Rosaceae	1	1						
Parsp2	<i>Paranephelium sp. 1</i>	Sapindaceae	4		4					
Parxer	<i>Paranephelium xerophyllum</i>	Sapindaceae	11	2	9					
Polsp1	<i>Polyalthia sp. 1</i>	Lauraceae	1	1						
Polsum	<i>Polyalthia sumatrana</i>	Annonaceae	5					2	1	2
Pompin	<i>Pometia pinnata</i>	Sapindaceae	1							1
Ptycos	<i>Ptychopyxis costata</i>	Euphorbiaceae	2		2					
Sanlae	<i>Santiria laevigata</i>	Burseraceae	1							1
Shojoh	<i>Shorea johorensis</i>	Dipterocarpaceae	35				15	17	3	
Sholep	<i>Shorea leprosula</i>	Dipterocarpaceae	2					2		
Shoova1	<i>Shorea ovalis</i>	Dipterocarpaceae	25		1		11	5	8	
Shopar	<i>Shorea parvifolia</i>	Dipterocarpaceae	18		1			16	1	
Shopol	<i>Shorea polyandra</i>	Dipterocarpaceae	156	38	21	43	2			52

Table 3. (Continuation)

FHM ID	Species Name	Family	Number of Trees in Cluster							
			Total Trees	1	2	3	4	5	6	7
Shosp1	<i>Shorea sp. 1</i>	Dipterocarpaceae	1				1			
Sinlei	<i>Sindora leiocarpa</i>	Caesalpinaceae	2				1		1	
Slosp1	<i>Sloanea sp. 1</i>	Elaeocarpaceae	7				2		4	1
Sterub	<i>Sterculia rubiginosa</i>	Sterculiaceae	1					1		
Strjav	<i>Strombosia javanica</i>	Olcaceae	1				1			
Talgig	<i>Talauma gigantifolia</i>	Magnoliaceae	1					1		
Xanhét	<i>Xanthophyllum heteropleurum</i>	Polygalaceae	2				1		1	
Xansp1	<i>Xanthophyllum sp. 1</i>	Polygalaceae	1						1	

Table 4. List of tree species and its distribution on FHM cluster-plots, Pulau Laut, year 2000

FHM ID	Species Name	Family	Number of Trees in Cluster							
			Total Trees	1	2	3	4	5	6	7
Acacat	<i>Acalypha caturus</i>	Euphorbiaceae	2		2					
Adetam	<i>Adenantha tamarindifolia</i>	Mimosaceae	1							1
Aglgan	<i>Aglia ganggo</i>	Meliaceae	3				1	1	1	
Alemol	<i>Aleurites moluccana</i>	Euphorbiaceae	2		2					
Alpjav	<i>Alphonsea javanica</i>	Annonaceae	1	1						
Antcad	<i>Anthocephalus cadamba</i>	Rubiaceae	1					1		
Antchi	<i>Anthocephalus chinensis</i>	Rubiaceae	3					1		2
Artani	<i>Artocarpus anisophyllus</i>	Moraceae	1				1			
Artela	<i>Artocarpus elasticus</i>	Moraceae	3		2					1
Artrig	<i>Artocarpus rigidus</i>	Moraceae	1						1	
Beigig	<i>Beilschmiedia gigantocarpa</i>	Lauraceae	1		1					
Botgen	<i>Botryophora geniculata</i>	Euphorbiaceae	1		1					
Canodo	<i>Cananga odorata</i>	Annonaceae	1	1						
Citsp1	<i>Citronella sp. 1</i>	lacinaceae	1							1
Crycra	<i>Cryptocarya crassinervia</i>	Lauraceae	1						1	
Dacros	<i>Dacryodes rostrata</i>	Burseraceae	2					1	1	
Dilexc	<i>Dillenia excelsa</i>	Dilleniaceae	1							1
Diocur	<i>Diospyros curraniopsis</i>	Ebenaceae	4		2		2			
Diomac	<i>Diospyros macrophylla</i>	Ebenaceae	7	2	2				2	1
Dipcau	<i>Dipterocarpus caudiferus</i>	Dipterocarpaceae	11				1	3	6	1
Dracos	<i>Dracontomelon costatum</i>	Anacardiaceae	1		1					
Dradao	<i>Dracontomelon dao</i>	Anacardiaceae	2	2						
Drysp1	<i>Drypetes sp.</i>	Euphorbiaceae	1						1	
Duracu	<i>Durio acutifolius</i>	Bombacaceae	5					1	4	

Table 4. (Continuation)

FHM ID	Species Name	Family	Number of Trees in Cluster							
			Total Trees	1	2	3	4	5	6	7
Enddia	<i>Endospermum diadenum</i>	Euphorbiaceae	1		1					
Eugsp1	<i>Eugenia sp. 1</i>	Myrtaceae	3		1					2
Euszwa	<i>Eusideroxylon zwageri</i>	Lauraceae	1	1						
Ficsp1	<i>Ficus sp. 1</i>	Moraceae	4							4
Geupen	<i>Geunisia pentandra</i>	Verbenaceae	3					3		
Gimer	<i>Girroniera nervosa</i>	Ulmaceae	2							2
Gluwal	<i>Gluta wallichii</i>	Anacardiaceae	1							1
Homfoe	<i>Homalium foetidum</i>	Flacourtiaceae	1	1						
Hopner	<i>Hopea nervosa</i>	Dipterocarpaceae	3				1			2
Knelau	<i>Knema laurina</i>	Myristicaceae	2		1					1
Lapsp1	<i>Laportea sp. 1</i>	Urticaceae	8		8					
Litben	<i>Lithocarpus bennetti</i>	Fagaceae	2							2
Litrox	<i>Litsea roxburghii</i>	Lauraceae	6	1	4					1
Litsp1	<i>Litsea sp. 1</i>	Lauraceae	1		1					
Macgig	<i>Macaranga gigantea</i>	Euphorbiaceae	1					1		
Macpru	<i>Macaranga pruinosa</i>	Euphorbiaceae	3		3					
Macsp1	<i>Macaranga sp. 1</i>	Euphorbiaceae	3	1						2
Malpen	<i>Mallotus penangensis</i>	Euphorbiaceae	1					1		
Mastri	<i>Mastixia trichotoma</i>	Cornaceae	1		1					
Myrine	<i>Myristica iners</i>	Myristicaceae	2		1			1		
Octsum	<i>Octomeles sumatrana</i>	Datiaceae	2	2						
Paldas	<i>Palaquium dasyphyllum</i>	Sapotaceae	1							1
Parkun	<i>Parinari kuntleri</i>	Rosaceae	1	1						
Parsp2	<i>Paranephelium sp. 1</i>	Sapindaceae	3		3					
Parxer	<i>Paranephelium xertophyllum</i>	Sapindaceae	6		6					
Polsp1	<i>Polyalthia sp. 1</i>	Lauraceae	1	1						
Pompin	<i>Pometia pinnata</i>	Sapindaceae	1							1
Ptycos	<i>Ptychopyxis costata</i>	Euphorbiaceae	2		2					
Sanlae	<i>Santiria laevigata</i>	Burseraceae	1							1
Shojoh	<i>Shorea johorensis</i>	Dipterocarpaceae	1							1
Shoova1	<i>Shorea ovalis</i>	Dipterocarpaceae	1		1					
Shopar	<i>Shorea parvifolia</i>	Dipterocarpaceae	1					1		
Shopol	<i>Shorea polyandra</i>	Dipterocarpaceae	112	25	14	42				31
Slosp1	<i>Sloanea sp. 1</i>	Elaeocarpaceae	5				2			3
Treori	<i>Trema orientalis</i>	Ulmaceae	1					1		
Verarb	<i>Vernonia arborea</i>	Compositae	1					1		

In 1996, *Shorea polyandra* appeared to be dominant in cluster 1, 2, 3, and 7, meanwhile *D. caudiferus* turned out to be relatively dominant in cluster 4, 5, and 6. In 2000, however, distribution of *S. polyandra* tremendously decreases and remains to be dominant in cluster 1, 2, 3, and 7. The same trend of distribution decline is also true for other important trees. The decline in species distribution over time of observation is primarily due to illegal logging activity and physical as well as biological damage in the course of time between 1996 and 2000.

Distribution of trees in terms of diameter class in tropical natural forest, so called total structure or stand structure, has been operated to depict the natural forest dynamic. In natural forest of un-even ages stand, the trees compete with one another for growing factors in the process towards mortality and generation.

Cluster 2, natural forest, is designated as Biodiversity Conservation Area. The area is dominated by *Shorea polyandra*. The highest occurrence of the tree is those bearing diameter classes ranging from 20-29.9 cm to 30-39.9 cm. Some trees reach the growth greater than 80 cm in diameter. The canopy of the forest is very dense as such that the canopy density blocks significantly the sunlight reaching to the forest floor. The regeneration and development of the seedlings, saplings and poles depend very much on the quantity and quality of light. The ratio between saplings, poles, nucleus trees and mature trees was 238:179: 91: 30 per ha based on observation in Year 2000.

The number of death trees was 84 trees per ha during the period of 1996 –2000 of which 36 were illegally cut, and 48 were physically and biologically damaged. Those death trees create a gap and the sunlight penetrates through the gap and reaches the forest floor to stimulate the plant growth. The changes and trends of sapling structure in natural forest are mostly affected by the dynamic of canopy opening-closure of the dominant trees and tree density.

Cluster 1 and 7 represent Buffer Zone, formerly was logged over area and the logging was conducted in 1978. As in the case of cluster 2, these clusters are predominated by *S. polyandra*. The highest probability of the tree diameter classes found in both clusters is almost the same, namely diameter classes ranges from 20-29.9 cm to 30-39.9 cm. The ratio between saplings, poles, nucleus trees and mature trees was 164:15: 58: 36 per ha based on observation in Year 2000 for cluster 1, meanwhile for cluster 7 the ratio was 253:60:60:38. From the observation made between 1996 and 2000, it is evident that 98 trees were death per ha due to logging (45 trees) and physical and biological damage (53 trees) in cluster 1. In contrast, the observation also proved that 95 trees were death per ha as affected by logging (75 trees), physical and biological damage (20 trees). In most cases, the diameter class distribution existed in natural

vegetation of *Shorea polyandra* as it occurred in cluster 1, 2, and 7 falls sharply at critical point of diameter 40 cm.

Cluster 3 is 25 year old plantation stand of *Shorea polyandra* wherein diameter distribution is dominated by tree with diameter class of 10-19.9 cm and followed by diameter class of 20-29.9 cm. The overall average of tree diameter at breast height is  $32.6 \pm 1.1$  cm, with mean annual increment of 1.3 cm. The ratio between saplings, poles, nucleus trees and mature trees was 0:119:85:0 per ha based on observation in Year 2000.

Cluster 4, 5, and 6 correspond to Seed Production Areas, in average are relatively rich in tree with diameter class 20-29.9 cm but far less in bigger tree with diameter greater than 30 cm. Figure 5 shows the abrupt decline of probability of having tree with the wider diameter class. The ratio between saplings, poles, nucleus trees and mature trees was 0:0:18:3 per ha based on observation in Year 2000 for cluster 4, meanwhile for cluster 5 and 6 the ratio were 30:149:11:8 and 149:45:73:5 respectively. In general, the three clusters severely underwent disturbances in which 203 trees were illegally cut, 5 trees were physically and biologically damaged, and 20 trees were burnt in cluster 4; 33 trees were illegally cut, and 193 trees were burnt in cluster 5; 95 trees were illegally cut, 13 trees were physically and biologically damage, and 85 trees were burnt in cluster 6.

Forest degradation occurs and visually can be recognized through canopy gap forming process or any disturbing forces against plant succession process. The degradation condition is at various extents and can be due to natural catastrophe and human activities as well such as typhoon, flood, pest and disease, forest fire, and logging. Degradation occurring in cluster 4, 5, and 6 where canopy gap forming is obvious, however, significantly affects the ground cover changes, and floristic composition of understory is presented in Table 5, 6, and 7, meanwhile list of understory species is shown in Table 8.

The vegetation type in cluster 4 is characteristically stratified in only one layer or stratum (plant height < 60 cm). The layer of the community in this cluster consists of *Paspalum conjugatum*, *Austroepatorium inulifolium*, and *Imperata cylindrica*. Each subplot in the cluster had a great similarity in floristic composition. This community occurred on severely damaged forestland where the influence of uncontrolled logging has been evident since late 1999. The canopy gap is as high as 90 % of total ground on flat to gentle slopes. The vegetation type in cluster 5, on the other hand, is generally stratified into four layers. The two lower layer of the community consists of several species for instance *Austroepatorium inulifolium*, *Costus speciosus*, and *Etilingera solaris*. The two upper layers on the other hand, consists of some species, and among them are *Macaranga gigantea*, *Callicarpa candicans*, and *Omalanthus populneus*. Each subplot in cluster 5 has considerable variation in the floristic composition and this type of community occurs on gentle slopes where the level of degradation is less than that in cluster 4. Notice that



the layers existing in cluster 5 is significantly richer as compared to the community layer in cluster 4.

Table 5. Floristic composition of cluster 4 after logging, year 2000

Sub Plot	Remark
1	<p><u>Stratum 1</u> : Plant height &lt; 60 cm</p> <p>Dominant : <i>Paspalum conjugatum</i></p> <p>Codominant : <i>Austroeupatorium inulifolium</i></p> <p>Frequent : <i>Cyperus killingia</i>, <i>Melastoma malabathricum</i>, <i>Cissus adnata</i>, <i>Zingiber sp.</i>, <i>Ficus vasculosa</i>, <i>Maranta arundinacea</i>, <i>Costus speciosus</i></p>
2	<p><u>Stratum 1</u> :</p> <p>Dominant : <i>Paspalum conjugatum</i></p> <p>Codominant : <i>Imperata cylindrical</i></p> <p>Frequent : <i>Lygodium circinatum</i>, <i>Leea indica</i>, <i>Solanum mammosum</i>, <i>Maranta arundinacea</i>, <i>Cyperus killingia</i>, <i>Fimbristylis miliacea</i>, <i>Diodia sp.</i>, <i>Ageratum conyzoides</i>, <i>Citronella sp.</i></p>
3	<p><u>Stratum 1</u> :</p> <p>Dominant : <i>Paspalum conjugatum</i></p> <p>Codominant : <i>Austroeupatorium inulifolium</i></p> <p>Frequent : <i>Melastoma malabathricum</i>, <i>Maranta arundinacea</i></p>
4	<p><u>Stratum 1</u> :</p> <p>Dominant : <i>Paspalum conjugatum</i></p> <p>Frequent : <i>Ludwigia hyssopifolia</i>, <i>Cyperus killingia</i>, <i>Erechtites valerianifolia</i>, <i>Hedyotis rigida</i>, <i>Austroeupatorium inulifolium</i>, <i>Stachytarpetta sp.</i>, <i>Hyptis capitata</i>.</p>

Table 6. Floristic composition of cluster 5 after logging, year 2000

Sub Plot	Remark
1	<p><u>Stratum 1</u> : Plant height &lt; 60 cm</p> <p>Frequent : <i>Maranta arundinacea</i>, <i>Pollia secundiflora</i>, <i>Xanthophyllum sp.</i>, <i>Austroeupatorium inulifolium</i>, <i>Nephrolepis exaltata</i>, <i>Costus speciosus</i></p> <p><u>Stratum 2</u> : Plant height 60 – 180 cm</p> <p>Frequent : <i>Santiria laevigata</i>, <i>Polyalthia sp.</i>, <i>Austroeupatorium inulifolium</i>.</p> <p><u>Stratum 3</u> : Plant height 180 – 480 cm</p>

Table 6. (Continuation)

Subplot	Remark
2	Frequent : <i>Santiria laevigata</i> , <i>Gluta wallichii</i> , <i>Macaranga gigantea</i> , <i>Omalanthus populneus</i> .
	<u>Stratum 4</u> : Plant height > 480 cm
	Frequent : <i>Dipterocarpus caudiferus</i> , <i>Callicarpa candicans</i> , <i>Macaranga gigantea</i> , <i>Omalanthus populneus</i> .
	<u>Stratum 1</u> :
	Frequent : <i>Paspalum conjugatum</i> , <i>Nephrolepis excalitata</i> , <i>Costus speciosus</i> , <i>Zingiber sp.</i> , <i>Pandanus sp.</i>
	<u>Stratum 2</u> :
	Frequent : <i>Dillenia eximia</i> , <i>Leea indica</i> , <i>Etilingera solaris</i> .
	<u>Stratum 3</u> :
Frequent : <i>Anthocephalus chinensis</i> .	
<u>Stratum 4</u> :	
Frequent : <i>Anthocephalus chinensis</i> .	
3	<u>Stratum 1</u> :
	Frequent : <i>Austro eupatorium inulifolium</i> , <i>Etilingera solaris</i> , <i>Polia secundiflora</i> , <i>Maranta arundinacea</i> , <i>Hedychium roxburghii</i> .
	<u>Stratum 2</u> :
	Frequent : <i>Maranta arundinacea</i> , <i>Austro eupatorium inulifolium</i> , <i>Etilingera solaris</i> , <i>Hedychium roxburghii</i> , <i>Polia secundiflora</i> , <i>Macaranga sp.</i>
	<u>Stratum 3</u> :
	Frequent : <i>Macaranga sp.</i> , <i>Callicarpa candicans</i> .
<u>Stratum 4</u> :	
Frequent : <i>Callicarpa candicans</i> , <i>Trema orientalis</i> .	
4	<u>Stratum 1</u> :
	Dominant : <i>Austro eupatorium inulifolium</i> .
	Frequent : <i>Paspalum conjugatum</i> , <i>Fimbristylis miliacea</i> , <i>Costus speciosus</i> , <i>Vernonia arborea</i> , <i>Glochidion sp.</i>
	<u>Stratum 2</u> :
	Dominant : <i>Austro eupatorium inulifolium</i> .
Frequent : <i>Fimbristylis miliacea</i> , <i>Vernonia arborea</i> , <i>Glochidion sp.</i>	

Table 7. Floristic composition of cluster 6 after logging, year 2000

Sub Plot	Remark
1	<p><u>Stratum 1</u> : Plant height &lt; 60 cm  Frequent : <i>Lygodium circinatum</i>, <i>Tetracera sp.</i>, <i>Maranta arundinacea</i>, <i>Ludwigia hyssopifolia</i>, <i>Macaranga pruinosa</i> <i>Etlingera solaris</i>.</p> <p><u>Stratum 2</u> : Plant height 60 – 180 cm  Frequent : <i>Lygodium circinatum</i>, <i>Ludwigia hyssopifolia</i>, <i>Etlingera solaris</i>, <i>Macaranga pruinosa</i>, <i>Callicarpa candicans</i>.</p> <p><u>Stratum 3</u> : Plant height 180 – 480 cm  Frequent : <i>Macaranga pruinosa</i>, <i>Callicarpa candicans</i>, <i>Dipterocarpus caudiferus</i>, <i>Anthocephalus chinensis</i>, <i>Gironniera subaequalis</i>.</p> <p><u>Stratum 4</u> : Plant height &gt; 480 cm  Frequent : <i>Callicarpa candicans</i>, <i>Trema orientalis</i>.</p>
2	<p><u>Stratum 1</u> :  Frequent : <i>Pollia secundiflora</i>, <i>Costus speciosus</i>, <i>Ficus vasculosa</i>, <i>Etlingera solaris</i>, <i>Leea indica</i>.</p> <p><u>Stratum 2</u> :  Frequent : <i>Etlingera solaris</i>, <i>Ficus vasculosa</i>, <i>Leea indica</i>.</p> <p><u>Stratum 3</u> :  Frequent : <i>Etlingera solaris</i>, <i>Callicarpa candicans</i>, <i>Macaranga pruinosa</i>, <i>Artocarpus elasticus</i>.</p> <p><u>Stratum 4</u> :  Frequent : <i>Euodia alba</i>, <i>Omalanthus populneus</i>, <i>Callicarpa candicans</i>, <i>Macaranga pruinosa</i>, <i>Macaranga gigantea</i>, <i>Dipterocarpus caudiferus</i>.</p>
3	<p><u>Stratum 1</u> :  Frequent : <i>Costus speciosus</i>, <i>Dioclea reflexa</i>, <i>Eugenia sp.</i>, <i>Sindora leiocarpa</i>, <i>Dysoxylum multijugum</i>, <i>Strombosia ceylanica</i>, <i>Zingiber sp.</i>, <i>Ficus vasculosa</i>, <i>Vernonia arborea</i>, <i>Pandanus sp.</i>, <i>Melastoma malabathricum</i>, <i>Diospyros macrophylla</i>.</p>

Table 7. (Continuation)

	<p><u>Stratum 2</u> :</p> <p>Frequent : <i>Costus speciosus, Sindora leiocarpa, Etlingera solaris, Eugenia sp., Diospyros macrophylla, Dysoxylum multijugum, Dipterocarpus caudiferus, Strombosia ceylanica, Vernonia arborea.</i></p> <p><u>Stratum 3</u> :</p> <p>Frequent : <i>Vernonia arborea, Sindora leiocarpa, Callicarpa candicans, Dipterocarpus caudiferus.</i></p> <p><u>Stratum 4</u> :</p> <p>Frequent : <i>Cananga odorata.</i></p>
4	<p><u>Stratum 1</u> :</p> <p>Frequent : <i>Maranta arundinacea, Austroeupatorium inulifolium, Costus speciosus, Etlingera solaris, Dillenia eximia, Dracontomelon dao, Endospermum diadenum.</i></p> <p><u>Stratum 2</u> :</p> <p>Frequent : <i>Maranta arundinacea, Austroeupatorium inulifolium, Etlingera solaris, Dillenia eximia, Dracontomelon dao, Endospermum diadenum.</i></p> <p><u>Stratum 3</u> :</p> <p>Frequent : <i>Etlingera solaris, Dracontomelon dao, Callicarpa candicans, Vernonia arborea, Endospermum diadenum, Trema orientalis.</i></p>

Table 8. List of understory species on FHM cluster plot, Pulau Laut

FHM ID	Species	Author	Family	Life Form	Location
Agltom	<i>Aglaia tomentosa</i>	Roxb.	Meliaceae	Tree	Cluster 1
Aglgan	<i>Aglaia ganggo</i>	Miq.	Meliaceae	Tree	Cluster 6
Agecon	<i>Ageratum conyzoides</i>	L.	Compositae	Shrub	Cluster 4
Antchi	<i>Anthocephalus chinensis</i>		Rubiaceae	Tree	Cluster 5,6
Artela	<i>Artocarpus elasticus</i>	Reinw. Ex Blume	Moraceae	Tree	Cluster 6
Bacsan	<i>Baccaurea sanguinea</i>	JJS	Euphorbiaceae	Tree	Cluster 7
Canodo	<i>Cananga odorata</i>	(Lamk) Hook.f. & Thomson	Annonaceae	Tree	Cluster 6
Cisadn	<i>Cissus adnata</i>	Roxb.	Vitaceae	Shrub	Cluster 4
Cypkyl	<i>Cyperus kyllingia</i>	Endl.	Cyperaceae	Herb	Cluster 4
Calcan	<i>Callicarpa candicans</i>	(Burn.f.) Hochr	Verbenaceae	Tree	Cluster 5
Citsp1	<i>Citronella sp.</i>		lacinaceae	Shrub	Cluster 4

Table 8. (Continuation)

FHM ID	Species	Author	Family	Life Form	Location
Cosspe	<i>Costus speciosus</i>	(Koenig) Smith	Zingiberaceae	Herb	Cluster 4,5,6
Dilexi	<i>Dillenia eximia</i>		Dilleniaceae	Tree	Cluster 5,6
Dioref	<i>Dioclea reflexa</i>	Hook.f.	Papilionaceae	Shrub	Cluster 2
Diosp1	<i>Diodia sp.</i>		Rubiaceae	Shrub	Cluster 4
Diomac	<i>Diospyros macrophylla</i>	Bl.	Ebenaceae	Tree	Cluster 6
Dipcau	<i>Dipterocarpus caudiferus</i>	Merr	Dipterocarpaceae	Tree	Cluster 6
Dradao	<i>Dracontomelon dao</i>	(Blaues)Morr et Ralph	Anacardiaceae	Tree	Cluster 6
Dysmul	<i>Dysoxylum multijugum</i>	Adlb	Meliaceae	Tree	Cluster 6
Elasp1	<i>Elatostachys sp.</i>		Sapindaceae	Tree	Cluster 2
Endmol	<i>Endospermum moluccanum</i>	(Teysm.&Binn.)Kurz.	Euphorbiaceae	Tree	Cluster 4
Enddia	<i>Endospermum diadenum</i>	Airy Shaw	Euphorbiaceae	Tree	Cluster 6
Ereval	<i>Erechtites valerianifolia</i>	Raf	Compositae	Shrub	Cluster 4
Euppal	<i>Eupatorium pallescens</i> (Syn. <i>Austroeupatorium inulifolium</i> )	(Kunth) King & Robinson	Compositae	Shrub	Cluster 4,5,6
Euoaib	<i>Euodia alba</i>		Rutaceae	Tree	Cluster 6
Eugsp1	<i>Eugenia sp.</i>		Myrtaceae	Tree	Cluster 6
Etsol	<i>Etilingera solaris</i>	(Bl.) Smith.	Zingiberaceae	Herb	Cluster 5,6
Ficsp1	<i>Ficus sp.</i>		Moraceae	Shrub	Cluster 4
Fimmil	<i>Fimbristylis miliacea</i>	Vahl.	Cyperaceae	Herb	Cluster 4
Ficvas	<i>Ficus vasculosa</i>	Walt	Moraceae	Shrub	Cluster 6
Garsp1	<i>Gardenia sp.</i>		Rubiaceae	Tree	Cluster 3
Girsub	<i>Gironniera subaequalis</i>	Planchon	Ulmaceae	Tree	Cluster 6
Glosp2	<i>Glochidion sp.</i>		Euphorbiaceae	Tree	Cluster 5
Gluwal	<i>Gluta wallichii</i>	(Hook f.),Ding Hou	Anacardiaceae	Tree	Cluster 5
Hedrox	<i>Hedychium roxburghii</i>	Bl.	Zingiberaceae	Herb	Cluster 2
Hedrig	<i>Hedyotis rigida</i>	Miq.	Rubiaceae	Shrub	Cluster 4
Hypcap	<i>Hyptis capitata</i>		Labiatae	Shrub	Cluster 4
Impcyl	<i>Imperata cylindrica</i>	(L.) Beauv.	Gramineae	Grass	Cluster 4
Ludhys	<i>Ludwigia hyssopifolia</i>	(G.Don)Exell	Onagraceae	Fern	Cluster 4
Lygcir	<i>Lygodium circinatum</i>	(Burm.f)Swartz	Schizaeaceae	Fern	Cluster 4
Leeind	<i>Leea indica</i>	(Burm.f.) Merr.	Leeaceae	Shrub	Cluster 4,5,6
Machyp	<i>Macaranga hypoleuca</i>		Euphorbiaceae	Tree	Cluster 1
Macsp1	<i>Macaranga sp.</i>		Euphorbiaceae	Tree	Cluster 5
Macgig	<i>Macaranga gigantea</i>	(H.G. Reichenbach & Zollinger) Muell. Arg	Euphorbiaceae	Tree	Cluster 5,6
Macpru	<i>Macaranga pruinosa</i>	(Miquel) Muell. Arg.	Euphorbiaceae	Tree	Cluster 6
Mararu	<i>Maranta arundinacea</i>	L.	Marantaceae	Herb	Cluster 4,5,6
Melmal	<i>Melastoma malabathricum</i>	L.	Melastomataceae	Shrub	Cluster 4,6
Nepjug	<i>Nephelium juglandifolium</i>	Bl.	Sapindaceae	Tree	Cluster 2

Table 8 (Continuation)

FHM ID	Species	Author	Family	Life Form	Location
Nepexc	<i>Nephrolepis exaltata</i>		Schizaeaceae	Fern	Cluster 4
Omapop	<i>Omalanthus populneus</i>	(Geisder)Pax	Euphorbiaceae	Tree	Cluster 5
Pansp1	<i>Pandanus sp.</i>		Pandanaceae	Shrub	Cluster 5,6
Plecon	<i>Plectronia conferta</i>		Rubiaceae	Shrub	Cluster 3
Pascon	<i>Paspalum conjugatum</i>	Berg.	Graminae	Grass	Cluster 4
Polsec	<i>Pollia secundiflora</i>	(Bl.)Bakh.f.	Commelinaceae	Herb	Cluster 5
Polsp1	<i>Polyalthia sp.</i>		Annonaceae	Tree	Cluster 5, 7
Rhycor	<i>Rhynchospora corymbosa</i>	Britton	Cyperaceae	Herb	Cluster 5
Sanlae	<i>Santiria laevigata</i>	Blume	Burseraceae	Tree	Cluster 5
Solmam	<i>Solanum mammosum</i>	L.	Solanaceae	Shrub	Cluster 4
Staind	<i>Stachytarpheta indica</i>	(L.) Vahl	Verbenaceae	Shrub	Cluster 4
Strcey	<i>Strombosia ceylanica</i>	Gardner	Olacaceae	Tree	Cluster 4
Sinlei	<i>Sindora leiocarpa</i>	Backer ex de Witt	Caesalpinaceae	Tree	Cluster 6
Tetsp1	<i>Tetracera sp.</i>		Dilleniaceae	Shrub	Cluster 6
Treori	<i>Trema orientalis</i>	(L.) Blume	Ulmaceae	Tree	Cluster 5,6
Verarb	<i>Vernonia arborea</i>	Ham.	Compositae	Tree	Cluster 5
Xansp1	<i>Xanthophyllum sp.</i>		Polygalaceae	Tree	Cluster 5
Zinsp1	<i>Zingiber sp.</i>		Zingiberaceae	Herb	Cluster 4,5,6

The vegetation type in cluster 6, moreover, is characteristically stratified into four layers. The two lower layer of the community consists of many species for instance *Lygodium circinatum*, *Ludwigia hyssopifolia*, *Etingera solaris*, and *Costus speciosus*. The two upper layers, in contrast, consists of some species like *Callicarpa candicans*, *Macaranga pruinosa*, and *Dipterocarpus caudiferus*. Each subplot in this cluster has great variation in floristic composition. This community occurs on gentle slopes where the level of degradation is about the same as that in cluster 5 as indicated by the number of layer existing in the cluster.

The above mentioned observation indicates that degraded forest of cluster 4, 5, and 6 as shown on the decrease in number of sapling, pole, nucleus tree, and mature tree, had also influenced tremendously the composition of understory species as a result of significant gap opening. Based on the observation conducted in 2000, the cluster 4 can be classified as shrub forest, and cluster 5 and 6 as heavily degraded forest. In most cases, soil organic matter content is lower than the other clusters. This unfortunate condition, however, should be put into account if rehabilitation of the degraded forest is our concern. This is to say that important processes, such as organic litter decomposition, available nutrient, and water uptake occur in humus layer. The establishment of saplings or poles may cause changes in the immediate environment for instance shading, as branch and root system, and these changes in turn influence soil biological processes.

Even though a sapling is subjected to a strong selection from its own environment in the first years of its life, its influence on the environment happens to be more and more prominent and increases in space as its crown and root system enlarge and eventually fuse with those other saplings. Similar effects are reported with herbaceous and woody ground vegetation, especially when single species becomes dominant and durably established (Emmer, 1994). Humus layers formed during the development of particular kinds of ground vegetation or forest stands may in turn influence the subsequent course of forest dynamics via their selective action on seedling establishment.

The interesting point raising from this work is the fact that *S. polyandra* growth in natural forest (cluster 1, 2, and 7) is superior as compared to those growing in the plantation forest at the age of 25 years (cluster 3) although the site quality corresponding to the solum thickness is significantly shallower in the cluster 1, 2, and 7. The *S. polyandra* plantation was established in 1976 with spacing 3 m by 3 m on the site with thick solum, approximately three times as thick as the solum in natural forests. Thinning was not implemented deliberately but natural thinning is the only incident observed as such that more space was available for plant growth. If factors affecting the growth of *S. polyandra* are presumed to be the same throughout all topographical position observed except for the capacity of soil to provide nutrients in adequate amount, then hypothetically speaking, the diameter growth of *S. polyandra* in cluster 2 to be about the same as 32.6 cm at average in the diameter of 25 year old *S. polyandra* cluster 3, will require much longer period than 25 years. The implication of the previous presumption is that degradation process occurs in the cluster with higher altitude and steep slope will need tremendous effort to rehabilitate and to recover its former climax.

#### IV. CONCLUSIONS

Soil pH and soil organic carbon decreased with the decrease in topographical position in most cases. The decrease in soil pH and soil organic carbon as well may also be due to changes in management regime of the study site in which Cluster 2 vegetation was still covered by relatively dense shorea trees, while the vegetation existed in Cluster 1 was logged over area (logged in 1978), and Cluster 3 was a 25-year old *Shorea polyandra* plantation. In this observation, the influence of relief was expressed mainly in the depth of soil and its organic litter and hence the cation exchange capacity (CEC). The difference in solum thickness, genetic part of the soil, among the three representatives of soil profile is obvious in which the solum thickness was least on high altitude and on steep slopes as it occurred in cluster 2, and it turned out to be thicker in lower altitude as it occurred in cluster 1 and 3 successively. In 1996, *Shorea polyandra* appeared to be dominant in cluster 1, 2, 3, and 7, meanwhile *D. caudiferus* turned out to be relatively dominant in

cluster 4, 5, and 6. In 2000, however, distribution of *S. polyandra* tremendously decreases and remains to be dominant in cluster 1, 2, 3, and 7. The same trend of distribution decline is also true for other important trees. The decline in species distribution over time of observation is primarily due to illegal logging activity and physical as well as biological damage in the course of time between 1996 and 2000. The fact that diameter growth of 25 year old *S. polyandra* plantation in cluster 3 was about 32.6 cm at average cluster 3 suggests that disturbances toward the natural *S. polyandra* forest in cluster 2, a biodiversity conservation area, take significantly longer period of time to recover its former climatic condition. This argument is made owing to the fact that the solum thickness in cluster 2 is the least among the other two sites namely cluster 1 and 3, and provided that other growing factors are assumed to be the same.

#### ACKNOWLEDGEMENT

This Technical Report No. 26 on **A Study of Soil and Vegetation Dominated by *Shorea polyandra* on Forest Health Monitoring Plots in Pulau Laut** has been prepared to fulfill Objective 1 point 2.2 of the Work-plan of ITTO Project PD 16/95 Rev. 2 (F): Forest Health Monitoring to Monitor the Sustainability of Indonesian Tropical Rain Forest.

The authors would like to thank ITTO, Ministry of Forestry (GOI) and PT. INHUTANI II for their supports. Appreciation also goes to the Project Steering Committee members for their suggestions.

#### REFERENCES

- Bohn, H.L., B.L. McNeal, G.A. O'Connor. 1985. Soil chemistry. John Wiley & Sons, New York.
- Emmer, I.M. 1994. Humus form characteristics in relation to undergrowth vegetation in a *Pinus sylvestris* forest. *Acta Oecologica* 15: 677-687.
- Godron, M., and R.T.T. Forman. 1983. Landscape modification and changing ecological characteristics. p.12-28. In H.A. Money and M. Gordon (Eds.) *Disturbance and Ecosystems*, Springer, Berlin.
- Noordwijk, M. van, C. Cerri, P.L. Woomer, K. Nugroho, and M. Bernoux. Soil carbon dynamics in the humid tropical forest zone. 1997. *Geoderma* 79: 187-225.
- Palm, C.A., R.A. Houghton, J.M. Mellilo, and D.L. Skole. 1986. Atmospheric carbon dioxide from deforestation in Southeast Asia. *Biotropica* 18: 177-188.
- Ponge, J.F., and L. Delhaye. 1995. The heterogeneity of humus profiles and earthworm communities in a virgin beech forest. *Biology and Fertility*.



- Ponge, J.F., J. Andre, O. Zackrisson, N. Bernier, M.C. Nilsson, C. Gallet. 1998. The forest regeneration puzzle, biological mechanisms in humus layer and forest vegetation dynamics. *Bio Science* 48: 523-530.
- Tan, K.H. 1994. *Environmental soil science*. Marcel Dekker, Inc., New York.
- USDA Forest Service. 1999. *Forest Health Monitoring 1999 Field Methods Guide*. USDA Forest Service, National Forest Health Monitoring Program, Research Triangle Park, NC 27709.
- Zhang, H., K.H. Hartge, and H. Ringe. 1997. Effectiveness of organic matter incorporation in reducing soil compactibility. *Soil Sci. Soc. Am. J.* 61: 239-245.

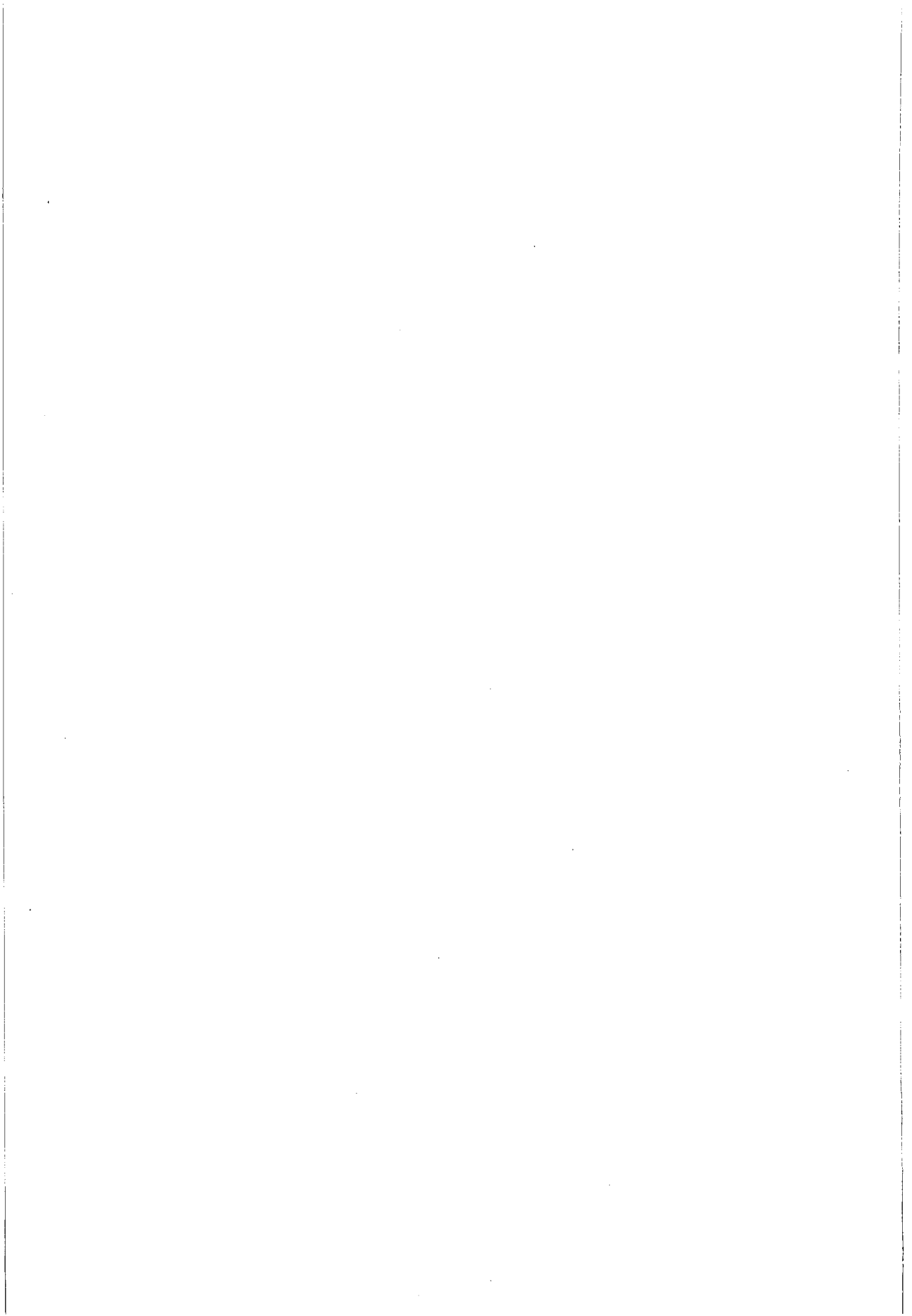

# ASSESSMENT ON SOCIO-ECONOMIC AND CULTURAL INDICATOR OF FOREST HEALTH MONITORING

*Technical Report No. 27*

Bahruni  
Dudung Darusman  
Erianto Indra Putra  
Djohan Setiawan

## ABSTRACT

The indicators of well-managed forest ecosystem must be equally defined by the environmental, economic as well as social attributes. The objective of this study is to assess the socio-economic and cultural indicator in the Forest Health Monitoring program. It was conducted at four villages in Pulau Laut and one village in Jambi. Data and information were collected in the form of verifiers or parameters using the Survey and non-survey method (Focus Group Discussion). This study exposed that forest-dwellers are generally dependent on the forest resources for their livelihood. They realized that forest timber and non timber product tend to be exhausted or even will be used up near in the future as a result from natural damage such as forest fire and illegal cutting. Since most of the forest-dwellers knew the FMU boundaries, less conflict occurred about the forest boundaries as found in Pulau Laut. The economical situation drives them to make illegal cutting, illegal log skidding and transporting it away although they know it is prohibited. Moreover, the inability of local community when facing the illegal logger, and lack of sense of belonging nor collective interest between forest-dwellers and FMU implicated to the unconditional effort in protecting the forest. Another important aspect was the effort of both parties, FMU and people community, to meet their mutual interest. The forest-dwellers well-being score in PT Asialog, Jambi was higher than in PT INHUTANI II, Pulau Laut i.e. 6.660 and 5.435, respectively. It was assumed that meetings between FMU and forest-dwellers community of the Asialog forest were more frequently conducted rather than in Pulau Laut. The smallest score in Pulau Laut was derived also from the number of conflicts occurred between FMU and forest-dwellers community concerning the forest boundaries, and the illegal logging surrounding the FMU forest.

**Key words :** *FMU, forest-dwellers, forest resource, forest boundaries, criteria and indicators of sustainable forest management, forest-dwellers well-being score*

## I. INTRODUCTION

Forest in the tropics and its conservation has currently become an international issue rather than just a national or local one. Forest, particularly the tropical forest, needs to be protected as it has a major role in maintaining the quality of life of the world population.

Forest resources should provide significant benefits for people's life. Management and utilization of the forest resource should always create benefit for all parties connected with or have something to do with the forest resource. It should ensure

sustainability of the resource and benefit all parties concerned in a fair manner (Darusman and Bahrni, 1999).

One of the indicators suggested by ITTO Guidelines for well-managed tropical ecosystems (1991) was an acceptable level of environmental impact and socio-economic benefit. The indicators of well-managed forest ecosystem must be equally defined by the environmental, economic as well as social attributes.

The objective of this study is to assess the socio-economic and cultural indicator in the Forest Health Monitoring program. It was done through the identification, measurement and recording of important indicators of socio-economic and cultural aspects of local people's community around the forest which describe the condition and dynamics of the community, especially the interrelationship between local people's life, the forest and forest management.

## II. METHODS

Assessment of the socio-economic and cultural indicator in Forest Health Monitoring was conducted at four villages in Pulau Laut and one village in Jambi. The four villages in Pulau Laut are located around the forest of PT. INHUTANI II Forest Concession Holder : Langkang Lama, Langkang Baru, Betung, and Mekarapura. One village in Jambi, Tanjung Sari, is located near the Asialog Forest Concession Holder

Data and information were collected in the form of verifiers or parameters that can explain, describe or measure the indicators. Survey and non-survey method (Focus Group Discussion) were implemented.

The survey method was done by personal discussion and interview with the forest-dwellers. The purpose of this method is :

1. Recording or learning the land rights and land utilization of the people, and
2. Recording household income and expenditures.

The Focus Group Discussion (FGD) method is one of the techniques of Participatory Rural Appraisal (PRA). Data are obtained from in-depth and thorough discussions, which involve active participation of each member of the discussion group.

The purposes of FGD are:

1. Recording or learning rights of ownership and utilization of resources according to local norms,
2. Learning capacity of people to manage natural resources,
3. Identifying types and use of forest products utilized by the people, and their developments through the course of time,

4. Learning conflict resolution between people and the Forest Management Unit (FMU) or among themselves,
5. Learning the opinion of local communities concerning the distribution of benefits from forest management,
6. Learning the issues related with forest management from FMU, and
7. Learning the opinion of local communities concerning the question on who among the stakeholders have the right to conduct management activities and are responsible for that.

Interview was done with 61 respondents within the age ranging between 20 and 65 years old. Twenty-two among them came from Tanjung Sari; others from Langkang Lama (4), Langkang Baru (9), Betung (10), and Mekarpura (16), respectively.

Focus Group Discussions were done for 1 group in Langkang Lama, 4 groups in Langkang Baru, 1 group in Betung, 5 groups in Mekarpura, and 6 groups in Tanjung Sari. The FGD were also done for the FMU staff in PT INHUTANI II and PT Asialog. The stage in FGD is conducted by informal interview with formal and informal leaders, local officials, timber company workers, FMU staff, and forest-dwellers that take the forest resource as income source directly or indirectly.

### **III. RESULTS AND DISCUSSIONS**

#### **3.1. Villages profile**

##### **3.1.1. Mekarpura**

Mekarpura is located at Sub-district Northern Pulau Laut, Kota Baru Regency, South Kalimantan Province. The population (1998) was 2,066 people, consisting of 15 % Banjar Ethnic, 60 % Bugis, 8 % Javanese and others ethnics, 15 %.

Main employment of the population is farmer and vendor (Banjar and Javanese); brackish water aquaculture, wood industry, driver, vendor and breeder (Bugis). Some Bugis cutting the tree as their income.

The Javanese bought land from the indigenous people (mostly Bugis and Banjar). Some of the Bugis acquired their land by government transmigration program. Only small part of them acquired their land by inheritance.

##### **3.1.2. Langkang Lama and Langkang Baru**

Langkang Lama and Langkang Baru are located at Sub-district Pulau Laut Timur, Kotabaru Regency, South Kalimantan Province. The population of Langkang Lama (1998) was 791 people consisting of 50% Banjar Ethnic and 50% Javanese. The population of Langkang Baru (1998) was 1,577 people consisting of 50% Banjar Ethnic and 50% Javanese.

Since Langkang Lama and Langkang Baru were transmigration villages, most of the people were farmers. Some of them are employed at oil-palm plantation and household vendors. Some Banjar and Javanese became carpenters, log graders using carabao, or tree fellers. The Banjars also exploit the private gold mining in Betung.

Land ownership follows the patterns prepared by the government transmigration program; buy/lend from other transmigrants (for small part of the Javanese); and inherited land (for some parts of Banjar).

### 3.1.3. Betung

Betung is located at Sub-district Pulau Laut Timur, Kotabaru Regency, South Kalimantan Province. The population (1998) is 600 people, consisting of 90% Banjar ethnic and 10% Javanese, Balinese and Bugis Ethnics. Langkang Lama, Langkang Baru, and Betung are neighboring villages.

The main employment of the population is farming. Some of them became carpenters, log skidders or tree fellers, oil-palm plantation workers and household vendors. The Banjars also make use of the private gold mine in their neighborhood as the source of income.

Land ownership patterns of indigenous people were obtained by heredity. Some of them buy the land from their neighbors or other friends.

### 3.1.4. Tanjung Sari

Tanjung Sari is located at Sub-district Mestong, Batanghari Regency, Jambi Province. The population (1999) was 2,437 people, consisting of 50 % Jambi, Batak and Kerinci Ethnic, and 50 % Javanese and Sundanese Ethnics. This village was designed as transmigration village in 1996. Most of them are farmers, and the rest are sawit plantation workers, household and vegetable vendors, poultry breeders and animal hunters (mostly for deer and birds).

The land status and their distribution on each village studied are shown in Table 1.

Table 1. Land-Ownership Status of Interviewed Forest-Dwellers

Village	Ethnic	Land Status (%)			
		Heredity	Buy / Lend	Transmigration	Temporary Use
Pulau Laut					
1. Langkang Lama & Langkang Baru	1. Banjar	33.33	---	66.67	---
	2. Javanese	---	25.00	70.00	5.00
2. Betung	1. Banjar	94.74	5.26	---	---
3. Mekarapura	1. Banjar	25.00	75.00	---	---
	2. Bugis	7.69	61.54	23.08	7.69
	3. Javanese	---	100	---	---
Jambi					
4. Tanjung Sari	1. Jambi, Kerinci, Batak	---	---	100	---
	2. Javanese, Sundanese	---	---	100	---

Table 2. Source of Income of the Interviewed Forest-Dwellers

Village	Ethnic	Source of Income (%)					
		Farmer	Forest	Gold Mining	Services /entrepreneur	Vendor	Breeder
Pulau Laut							
1. Langkang Lama Langkang Baru	1. Banjar	33.33	22.22	22.22	22.22	---	---
	2. Javanese	43.48	21.74	---	21.74	13.04	---
2. Betung	1. Banjar	34.62	23.08	26.92	11.54	3.85	---
3. Mekarpura	1. Banjar	50.00	---	---	---	50.00	---
	2. Bugis	31.25	6.25	---	31.25	31.25	---
	3. Javanese	50.00	---	---	---	50.00	---
Jambi							
4. Tanjung Sari	1. Jambi, Kerinci, Batak	36.36	9.09	---	27.27	18.18	9.09
	2. Javanese, Sundanese	37.78	2.22	---	35.56	8.89	15.56

Table 3. Total Income of the Interviewed Forest-Dwellers

Village	Ethnic	Income Value (Rp./year) by Source						Total
		Farmer	Forest	Gold Mining	Services /entrepreneur	Vendor	Breeder	
Pulau Laut								
1. Langkang Lama, Baru	1. Banjar	3,516,667 30.62%	2,040,000 17.76%	840,000 7.31%	5,088,000 44.30%	---	---	11,484,667
	2. Javanese	3,965,000 37.86%	1,051,600 10.04%	---	1,155,000 11.03%	4,300,000 41.06%	---	10,471,600
2. Betung	1. Banjar	2,802,222 23.76%	3,213,333 27.24%	1,927,429 16.34%	2,053,333 17.41%	1,800,000 15.26%	---	11,796,317
	3. Mekarpura	5,900,000 83.89%	---	---	1,175,000 16.61%	---	---	7,075,000
	2. Bugis	858,200 5.11%	2,415,000 14.38%	---	10,920,000 65.01%	2,605,000 15.51%	---	16,798,200
	3. Javanese	1,500,000 60%	---	---	---	1,000,000 40%	---	2,500,000
Jambi								
4. Tanjung Sari	1. Jambi, Kerinci, Batak	1,198,333 14.15%	2,400,000 28.34%	---	1,140,000 13.46%	3,300,000 38.97%	400,000 4.72%	8,468,333
	2. Javanese, Sundanese	970,000 17.88%	400,000 7.37%	---	905,625 16.69%	2,695,000 49.66%	454,286 8.37%	5,424,911

### 3.2. Forest-dwellers, Forest and Forest Management Unit (FMU)

Human demands on the forest fall under two categories. First, a demand for forest quantities; actually forest can produce: timber, food and space for cultivation or for grazing. Second, a demand for forest qualities; for the effects that forests have on the environment of man – to protect supplies of water, provide havens for wildlife, to maintain the pool of genetic resource, to protect the soil against erosion, and to provide space for recreation (Hallsworth, 1982).

This study pointed out that local people around the forest are generally dependent on the forest resources for their livelihood. The forest contributes to the food needs of forest-dwellers, provides fresh air, provides employment for some of them, protects their land from flood and erosion, and supplies water for their land cultivation (see Table 4).

Table 4. Dweller's Opinion on the Forest Contribution for Their Livelihood

Village	Ethnic	Forest Contribution (%)				
		Contributes the food needs	Provides fresh air	Provides employment	Supplies water	Prevents land from flood and erosion
Pulau Laut						
1. Langkang Lama Langkang Baru	1. Banjar	40.00	75.00	50.00	80.00	75.00
	2. Javanese	20.00	80.00	20.00	100.00	100.00
2. Betung	1. Banjar	30.00	75.00	40.00	80.00	75.00
3. Mekarapura	1. Banjar	20.00	80.00	40.00	60.00	80.00
	2. Bugis	20.00	80.00	40.00	40.00	60.00
	3. Javanese	10.00	80.00	5.00	60.00	40.00
Jambi						
4. Tanjung Sari	1. Jambi, Kerinci, Batak	60.00	100.00	60.00	90.00	80.00
	2. Javanese, Sundanese	40.00	100.00	40.00	50.00	75.00

Note: One respondent could have more than one opinion

Since most of the forest-dwellers are farmers, most of them are well-informed that forests will provide water supplies for their agricultural land; prevents their land from flood and erosion; provides fresh air; and contributes to their food needs (honey, vegetables and meat).

Lesser percentage were found for the forest contribution in providing the employment for forest-dwellers. This correlates with their main employment as farmer (see Table 2). Only a small part of forest-dwellers in Langkang Lama, Langkang Baru, and Tanjung Sari make use of the forest as their second employment (as carpenters, animal hunters, log grader, tree feller), but the main employment of most forest-dwellers in Mekarapura and Betung.

Some parts of Banjar (Langkang and Betung) as well as Jambi and Kerinci Ethnics (Tanjung Sari) hunt for wild animals from the forest such as deer, bird, pig, fish, and bear to be eaten or to be sold. Some transmigrants in Tanjung Sari collect rattan to be sold or to be used for their own.

Illegal tree felling and log skidding was the most common forest occupation found in Langkang, Betung, and Mekarapura. They are paid to cut down the trees, pull them out from the forest, and transport them away (some truck drivers in Mekarapura transported the illegal logs). The economic situation caused the forest-dwellers to take this job, although they are aware that it is illegal or forbidden.

Most of the forest-dwellers know the FMU boundaries (Table 5). They know that it is prohibited to cut down the tree or to have a private plantation in the area without any permission from the forest managers. Few conflicts arise at FMU boundaries between forest-dwellers in Langkang Lama and PT INHUTANI II resulting from some forest-dwellers having their own private plantation in the PT INHUTANI II area. They claimed that it is still their land. The same condition happened in Mekarapura (Table 6).



Table 5. Knowledge Level for the FMU's boundaries

Village	Ethnic	Know / Did Not Know (%)					Not
		Know					
		MA	A	NO	DA	MDA	
Pulau Laut							
1. Langkang Lama, Baru	1. Banjar	---	30.00	40.00	--	---	30.00
	2. Javanese	---	30.00	20.00	20.00	10.00	20.00
2. Betung	1. Banjar	---	---	70.00	---	30.00	---
3. Mekarpura	1. Banjar	---	16.67	33.33	16.67	---	33.33
	2. Bugis	---	8.33	---	---	---	91.67
	3. Javanese	---	60.00	30.00	---	---	10.00
Jambi							
4. Tanjung Sari	1. Jambi, Kerinci, Batak	---	25.00	---	25.00	---	50.00
	2. Javanese, Sundanese	---	16.67	11.11	11.11	5.56	55.56

Note : MA : Most Agree with the FMU boundaries      DA : Disagree with the FMU boundaries  
 A : Agree with the FMU boundaries                      MDA : Most Disagree with the FMU boundaries  
 NO : No opinion

Table 6. Private Plant in the FMU's forest

Village	Ethnic	Have / No (%)	
		Have	No
Pulau Laut			
1. Langkang Lama, Baru	1. Banjar	---	100.00
	2. Javanese	30.00	70.00
2. Betung	1. Banjar	---	100.00
3. Mekarpura	1. Banjar	33.33	66.67
	2. Bugis	---	100.00
	3. Javanese	---	100.00
Jambi			
4. Tanjung Sari	1. Jambi, Kerinci, Batak	---	100.00
	2. Javanese, Sundanese	---	100.00

### 3.3. Criteria and Indicators of Sustainable Forest Management on Forest Health Monitoring

Some Criteria and Indicators to monitor Sustainable Forest Management (SFM) have been developed by CIFOR and LEI (Indonesian Ecolabelling Institute. Forest Health Monitor (FHM) use some Criteria and Indicator as follows :

#### 3.3.1. Criteria: Access and Control to Resources and Forest Management by Local Communities and Ensured

##### 3.3.1.1. Indicator : Ownership and use right to resources (inter and intra generation) are clear and respect preexisting claims, and traditional local norm

The uncertainty in land possessing could highly effect the SFM. This happened if there are overlapping land ownership between Government and local people surrounding the forest who believe that they have the right of the land based on traditionally law.

Changes on ethnic composition (Table 7) is important especially in explaining the people norm development regarding the land possession, management and natural resources utilization, particularly forests.

Several tribes live surrounding the forest. Some of them come from outside the village as Government transmigrant group or individual migration. The transmigrant group

initially possess their land through legal process as registered owner, either buying from local people or renting it. The newcomers then adapted the existing regulation on land possession of the local people.

There were still a lot of land area being unutilized optimally due to the lack of labor, lack of expertise in crops weeds (pig, monkey and birds) and capital limitation. When the farmers not cultivate their own land, they may ask the newcomers to till the land by lease system.

Table 7. Ethnic Composition Change of People at Village Around the Forest

Village	Ethnic	Ethnic Composition (%)	
		1960 - 1970	1999
Pulau Laut			
1. Langkang Lama, Langkang Baru	1. Banjar	40	50
	2. Javanese, Sundanese, Balinese	60	50
	3. Bugis	0	0
2. Betung	1. Banjar	100	95
	2. Javanese, Sundanese, Balinese	0	5
	3. Bugis	0	0
3. Mekarapura	1. Banjar	65	41
	2. Javanese, Sundanese, Balinese	2	12
	3. Bugis	33	47
Jambi			
4. Tanjung Sari	1. Javanese, Sundanese, Balinese	0	60
	2. Jamb, Kerinci, Batak	0	40

Conflict between interest and desire regarding the land and forest resource between local people and Forest Management Unit (FMU) does not happen often. However, it does not mean that there is no conflict in the long run in FMU forest area. Forest managers were inactive in involving the local people participation in preparing the official forest boundary documents. Moreover, when the definite boundary has been drawn up, there is not enough effort made by FMU to socialize it to the local people. This matter caused un satisfaction of the local people. Despite of the land ownership right was clearly regulated based on the local norms, in the long-term these regulations could not be accommodated in the FMU forest area. Thus, this kind of situation will influence the forest sustainability in the future.

### 3.3.1.2. Indicator : Local communities, forest dwellers have sufficient capacity to manage their resources sustainably

Local people dependant on the forest resources. The resource utilization is managed by local norm, i.e. logging could be done only on their area or on the unknown land property. However, the need for forest product changes significantly from own consumption to the market purposes (Table 8).

Table 8. Change on Forest Products Purposes by Forest Dwellers

Village	Forest Product	Purposes (%)			
		5-10 years ago		Current	
		Consumption	Sale	Consumption	Sale
Pulau Laut					
1. Langkang Lama, Baru	Ulin (Timber)	95	5	10	90
	Meranti (Timber)	0	0	0	100
	Keruing (Timber)	0	0	0	100
	Rattan	0	100	0	0
	Deer	50	50	25	75
2. Betung	Ulin (Timber)	25	75	0	100
	Meranti (Timber)	0	100	0	100
	Keruing (Timber)	0	100	0	100
	Rattan	0	100	0	0
	Deer	80	20	20	80
3. Mekarpura	Ulin (Timber)	75	25	5	95
	Meranti (Timber)	75	25	5	95
	Keruing (Timber)	75	25	5	95
	Rattan	90	10	15	85
	Durian (fruit)	50	50	5	95
Jambi					
4. Tanjung Sari	Timber	0	0	100	0
	Deer	0	0	50	50
	Bird	0	0	50	50
	Rattan	0	0	20	80

Table 9 shows the forest-dwellers view of forest timber and non-timber product. It was said that both of forest products tend to be rare, and some of them will disappear.

Table 9. Changes on Forest Product Stock According to Forest Dwellers

Village	Forest Product	Time				Total
		1970 - 80	1990	1999	2005	
1. Langkang Lama, Baru	Ulin (Timber)	65	30	5	0	100
	Meranti (Timber)	50	30	15	5	100
	Keruing (Timber)	50	30	15	5	100
	Rattan	75	25	0	0	100
	Deer	60	25	12	3	100
2. Betung	Ulin (Timber)	60	30	10	0	100
	Meranti (Timber)	50	30	15	5	100
	Keruing (Timber)	50	30	15	5	100
	Rattan	75	23	2	0	100
	Deer	65	25	10	0	100
3. Mekarpura	Ulin (Timber)	75	25	0	0	100
	Meranti (Timber)	50	38	12	0	100
	Keruing (Timber)	50	38	12	0	100
	Rattan	57	29	14	0	100
	Durian (fruit)	45	35	15	5	100
4. Tanjung Sari	Timber	ND	ND	70	30	100
	Deer	ND	ND	75	25	100
	Bird	ND	ND	55	45	100
	Rattan	ND	ND	77	23	100

Note : ND : No data

Some factors influencing the rareness of forest product for local communities are as follows:

1. Government land-used regulation was implemented without considering the local people's land right. Establishment of oil palm plantation and transmigration settlements decreased the local people area.

2. The big-harmful forest fire and long dry season in 1997 – 1998 has destroyed the forest product resources, e.g. rattan. Forest-dwellers believe that the availability of rattan and other forest products will become scarce in the near future.
3. Increasing forest produce utilization caused by the population growth with limited managing capacity to ensure the sustainability of forest resource.

**3.3.1.3. Indicator : Means of conflict solving functions transparently and without violence, among stakeholders, including illegal cutting problem**

Any conflicts that arise among local people will be solved by mutual understanding and with the involvement of formal and informal community leaders. Conflict among communities regarding forest resources rarely occurred due to the existing ownership right.

Some conflicts related to the FMU boundary and the owning of a private plant inside the FMU area arose between local people and FMU (as is the case in Langkang Lama, Langkang Baru and Mekarpura). The conflicts have not been solved yet as there is no instrument to handle it. Therefore, forest managers did not give the right to forest-dwellers and guarantee to access the forest. This was reflected in the forest boundaries determination without involving the local people. At this condition, there is no institutions nor rules respected by every stakeholder to ensure the right and duty of local community and FMU in forest management and utilization.

Ownership and natural resources (land & forest) management belong to the individual system. Consequently, any conflict related to natural resources is an individual conflict and not a community conflict.

There is no communal ownership on unknown natural property. Thus, the area is free for anyone and no norm developed effectively to manage the area. Local people institution was very weak when facing up with the illegal cutting done by outsiders in this area. It was expected that government institution could solve problems concerned with the community in overall that could not be solved by local institution.

**3.3..2. Criteria : Local communities have reasonable share in the economic benefits derived from forest use**

**3.3.2.1. Indicator : The increase of income level and income sources of local communities, forest dwellers**

Table 2 shows that forest contributes a significant source of income to forest-dwellers (22-23% in Langkang Lama, Langkang Baru and Betung; 13% in Mekarpura; 2-9% in Tanjungsari). Forest dwellers have four or five income sources (37.5%), while 25% has only two income sources.

Table 3 shows that the total income of people ranged between 9–10 million/ year/household, thus the net income is estimated to be between 5–7 million/ year/ household. This indicates that the net income lines was next to the poverty line.

The initial assumption that much more income source will decrease the dependency on one source (i.e. from forest) has been rejected as the overall income source was on lower level. It means that various sources of income are still be needed. Consequently, the accessibility and sustainability of forest resources are strong relation with the community life surrounding the forest.

The destruction of forest resources will have an impact on the forest dwellers prosperity. This could be worse when there is no improvement made by the local people in natural resources management (e.g. in agriculture, crops or forestry), while other promising source income rather than from the forest started to decrease.

The effect of this indicator on the sustainability of forest management will be higher in the future. The increasing need of local people necessity for forest resource will be developed by the FMU' managerial system in managing the forest, including the surrounding village.

#### **3.3.2.2. Indicator : Opportunities exist for local and forest dependent communities to be employed by Forest Management Unit (FMU)**

There are two important implication from this indicator : 1) influencing the FMU roles in supporting the increase of forest-dwellers income, especially for forest-dependent communities, and 2) influencing the relationship bond between FMU' interest in forest management with the interest of local people, as the sense of belonging of forest resources raised up together.

Almost no one in Langkang Lama, Langkang Baru and Betung are employed by FMU, and fewer ones in Tanjung Sari. Job opportunities for the forest-dwellers are restricted only for the field activity, not for a long-term prosperous employment.

Moreover, the inability of local community when facing the illegal logger, and lack of sense of belonging nor collective interest between forest-dwellers and FMU implicated to the unconditional effort in protecting the forest.

#### **3.4. Forest-dwellers well-being Scoring**

The forest-dwellers well-being surrounding the FMU was assessed by the use of scoring method based on the two criteria within its indicators as mentioned above. The total score then reflected the sustainability of the FMU forest and the relationship between FMU and local people surround them. The verifiers developed for each indicator are shown in Table 10.

The value ranged between 1 – 10; where '1' is for the worst and '10' for the best value (for verifiers 1.1.1., 1.2.2., 1.3.1., 1.3.2., 1.3.3., 2.1.1., 2.2.1.). In contrast, verifiers 1.1.2., 1.2.1, 2.1.2., 2.1.3. used '1' is for the best and '10' for the worst value.

The total score comes from individual score for each verifier developed. Each of the interviewed forest-dwellers has his individual score. Each indicator has one or more verifier(s). The average of every individual score of the same village will be the indicator score. Since the criteria has one or more indicator(s), the criteria score was come from the average of each indicator value. The criteria scores are then combined to be the FMU score.

The result showed that the total score of INHUTANI II FMU and Asialog FMU was 5.435 and 6.660 respectively. The small score on PT INHUTANI II (5.435) resulted from the number of unsolved conflicts between FMU and local people, the common illegal cutting and log transportation surrounding the FMU forest, and the unaccommodating most of the forest-dwellers desire comes from less of meetings between FMU and local people.

The moderate score on PT Asialog (6.660) mainly comes from the forest-dweller low income as their oil palm plantation did not produce yet. It was assumed as their oil palm plantation started to produce, their income will be increased and the score will be higher.

#### **IV. CONCLUSIONS**

One important aspect for the sustainability of the forest is the socio-economic cultural condition of the community around the forest.

Socio-economic criteria and indicator applied in FHM proved to be significant for monitoring towards sustainable forest management, considering the last and existing situation to the projection of future condition, especially social condition and culture.

The less number of meetings between FMU and forest-dwellers community nearby the PT INHUTANI II rather than in PT Asialog Jambi, numbers of conflict occurred between FMU and forest-dwellers community concerning the forest boundaries, and the illegal logging surround the FMU forest derived the smaller score of forest-dwellers well-being in Jambi than in Pulau Laut.

Another important aspect was the effort of both parties, FMU and people community, to meet their mutual interest.

Table 10. Criteria, Indicators and Verifiers Used in Assessing the Forest-dwellers well-being

No	Criteria	Indicator	Verifier
1.	Access and Control to Resources and Forest Management by Local Communities and Ensured (50%)	1. Ownership and use right to resources (inter and intra generation) are clear and respect preexisting claims, and traditional local norm (40%)	1. Respect on land ownership between local community and FMU that reflected in the forest boundary (50%) 2. Conflicts in land and forest utilization (50%)
		2. Local communities, forest dwellers have sufficient capacity to manage their resources sustainably (30%)	1. Forest product utilization for market demand is greater than self consumption (40 %) 2. Capacity level in maintaining the sustainability of their resource (60 %)
		3. Means of conflict resolution function transparently, equitably and without violence, among stakeholders, included illegal cutting problem (30%)	1. Conflict resolution (35%) 2. Gathering frequency between FMU and local people (25%) 3. Illegal cutting resolution (40%)
2.	Local communities have reasonable share in the economic benefits derived from forest use (50%)	1. The increasing of income level and income sources of local communities, forest dwellers (60%)	1. Income level (33.33%) 2. Forest contribution to income level (33.33%) 3. Dependency on forest product as source income (33.33%)
		2. Opportunities exist for local and forest dependent communities to receive employment from Forest Management Unit (FMU) (40%)	1. Opportunities for local and forest dependent communities to receive employment from FMU (100%)

Note : Number on the brackets represent the weighting factor of each score

### ACKNOWLEDGEMENT

This Technical Report No. 27 on the **Assessment on Socio-Economic and Cultural Indicator of Forest Health Monitoring** has been prepared to fulfill the additional objective of the Work-plan of ITTO Project PD 16/95 Rev. 2 (F): Forest Health Monitoring to Monitor the Sustainability of Indonesian Tropical Rain Forest.

The authors would like to thank ITTO, Ministry of Forestry (GOI), PT. INHUTANI II and PT. Asialog Forest Concession Holder for their support. Appreciation also goes to the Project Steering Committee members for their suggestions.

## REFERENCES

- CIFOR. 1998. The Criteria and Indicators Toolbox. CIFOR. Bogor.
- Darusman, D and Bahruni. 1999. Socio-Economic and Cultural Aspects. Hand-lecture at Training Course on Forest Health Monitoring for the Southeast Asian Scientists : 2 – 13 August 1999. SEAMEO-BIOTROP. Bogor.
- Hallsworth, E. G. 1982. The Human Ecology of Tropical Forest in Socio-economic Effects and Constraints in Tropical Forest Management. E.G. Hallsworth (ed.). John Willey & Sons Ltd. New York.
- Indonesian Ecolabelling Institute. 1998. Certification System of Sustainable Production Forest Management. Academical Text. Jakarta.
- Moody, R. 1992. Invasion of Borneo by Miners, Loggers and Transmigration in The Endangered Rainforest and the Fight for Survival. Vol. 2. World Rainforest Movement. Malaysia.
- Rametsteiner, E. The Use of SFM-Indicators as Tools in Political and Economic Contexts. Proceedings of International Conference on Indicators for Sustainable Forest Management : Forestry Stakeholders Input to Advance Development of Scientifically Based Indicators. Melbourne, 24 – 28 August 1998.



# ASSESSMENT ON CROWN INDICATORS OF FOREST HEALTH MONITORING

*Technical Report No. 28*

Kasno  
Supriyanto  
Simon Taka Nuhamara  
Erianto Indra Putra  
I Wayan Susi Dharmawan

## ABSTRACT

A study on assessment of crown indicators of forest health monitoring (FHM) as part of INDO-FHM project was carried out through two ways i.e. by means of field work and training course implementations. This study was mainly aimed at testing crown as one of the indicators of forest sustainability and applicability of FHM method under Indonesian tropical rain forest. The study has other objectives e.g. to investigate the possible correlation of crown parameters to the other parameters, to know the status of crown conditions and possible changes as well as trends within three years assessment period in the study sites. It was proven that crown might be one of the important indicators of forest sustainability. Meanwhile, crown parameters i.e. crown diameter, live crown ratio, crown density, foliage transparency and crown dieback may reflect forest health. In assessing forest stand dynamic and stand structure, crown parameters may be complementary to canopy parameters. In assessing forest tree vitality / vigor, crown parameters may be complementary to damage parameters. In assessing growth / productivity, crown size may be complementary to stem diameter / basal area. Crown parameter assessment as part of FHM method may be applicable to Indonesian tropical rain forest. Circular plot with radius of 7.32 m, in assessing crown conditions of a forest stand, is appropriate instead of larger plot.

**Key words :** *Crown, indicator, health, vigor*

## I. INTRODUCTION

Crown is the foliated part of a plant. Leaf is one of the key components of the living plant system. Leaf with appropriate chlorophyll and stomata is the only plant part capable of catching solar energy and conducting photosynthesis process to produce an organic compound, the carbohydrates, as the initial chemical energy for further processes of metabolism in the living plants.

A multitude of abiotic and biotic factors influence shape and size of forest trees. Individual tree vigor and growth are influenced by physiological age, available water and nutrients, and light resources at a site. Although climate and site conditions affect resource availability, a tree position relative to its neighbors is also critical in determining the amount of water, light, and nutrients available for any one tree (Cline, Steven P. 1995). Competition amongst trees in a forest stand may be reflected on the size and shape of the crowns.

As crown conditions are influenced by various environmental factors, crown condition reflects the preceding year growth processes. Meanwhile plant growth processes are influenced by various factors such as site quality, stand density, and other external stresses. Therefore, crown evaluations that quantitatively assess current tree conditions are really an integrated measure of site, stand density, and external stresses from the preceding days, months, years or decades (Cline, Steven P. 1995).

In 1989 the Government of Indonesia (GOI) established the National Inventory (NFI) Program, which was technically assisted by the FAO. The objectives of the program were providing information on the location and extend of the main forest types, estimating the standing stocks and growth rates, and assessing the status and change of the forest. In assessing the forest conditions, however, NFI program has not included forest tree crown as one of the indicators such as applied by USDA Forest Service in the Forest Health Monitoring (FHM) Program. FHM method was first developed in the US in 1991 and annually updated for improvement.

The FHM is an ecological approach to evaluate forest health for the status, changes and trends as well as the causal agents and mechanisms. It is a ground based assessment of the condition, changes and trends in the forests by means of monitoring the proportions of forest population that are in poor, sub nominal, nominal or optimal condition for each indicator. In 1996 the GOI in cooperation with ITTO initiated FHM project with technical assistant from USDA Forest Service experts. This project was then called INDO-FHM project. In this study crown is selected to be the indicator of tree/forest health and crown condition is assessed through the following parameters i.e. crown diameter, life crown ratio, foliage transparency, crown density and crown dieback.

This study was carried out through two means i.e. field work and training implementation. Field study was conducted in areas of PT. Asialog (Jambi Province), PT. INHUTANI II (in Pulau Laut, South Kalimantan Province) and Perum Perhutani Unit II (Kediri East Java Province). Meanwhile, training courses on Forest Health Monitoring Method were conducted at SEAMEO-BIOTROP (Bogor) and Faculty of Forestry, Gadjah Mada University (Yogyakarta).

This study was mainly aimed at testing crown as one of relevant indicators of tropical forest sustainability and the possible applicability of Forest Health Monitoring method under Indonesian tropical rain forest. The study has other objectives as follows : to investigate the correlation between crown parameters with other parameters, to know the status of crown conditions and possible changes as well as trends within three years assessment period in the study sites. If INDO-FHM project is successful to meet the targets and if the method is then adopted to be implemented by the Ministry of Forestry (GOI), FHM implementation would provide base line data for further sustainable Indonesian forest management.

## II. MATERIALS AND METHODS

### 2.1. Plot establishment

Circular research plots were established in each study site. The size, arrangement of the plots (Figure 1) and tree's crowns to be assessed followed the procedures of Forest Health Monitoring 1994 Field Methods Guide (Tallent-Halsell, 1996) and Forest Health Monitoring 1997 Field Methods Guide (USDA Forest Service, 1997).

### 2.2. Study sites

Research plots of INDO-FHM project were established in the areas of PT. Asialog, PT. INHUTANI II and Perum Perhutani Unit II. On the research plots, forest tree crown conditions were assessed according to Forest Health Monitoring Field Methods Guides and the applicability of the method was examined. Using same procedure, training plots were also established in the areas of PT. INHUTANI II (at Pulau Laut), Perum Perhutani Unit I (at Tawangmangu), Wanagama Research Station (at Gunung Kidul, Yogyakarta), Field Station of Forest Research and Development Agency (at Kaliurang, Yogyakarta) and Pangrango Mountain National Park (at Cibodas).

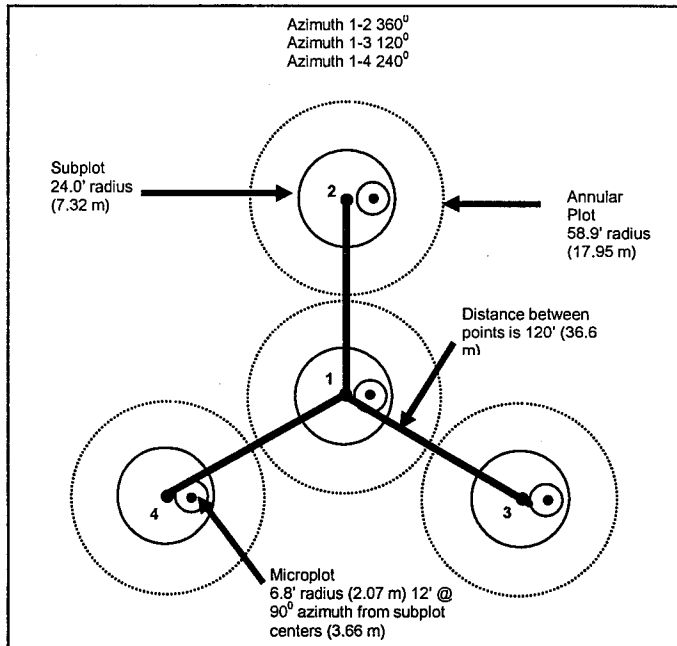

Figure 1. Four FHM plots arrangement of a cluster

The following is general information of each study site where research plots were established.

### **2.2.1. PT. Asialog**

PT. Asialog is located in Jambi Province and FHM plots were established in Limited Production Forest (clusters 1, 2, 3 and 4). The soil order falls into Oxisols and Ultisols. Some important physical and chemical nature of the soil are moderately coarse (topsoil) and moderately fine (subsoil), thick to very thick, very low to low exchangeable Ca, low to medium exchangeable Mg, low exchangeable K, low to medium exchangeable Na, low to medium CEC, very strong acid to strong acid in soil reaction, and low Al saturation.

Based on the criteria of Schmidt and Ferguson, the climate in the project site is categorized into Type A with annual rainfall average of 2,248 mm, and the average daily temperature is 26.5 ° C with relative humidity of 84 %.

### **2.2.2. PT. INHUTANI II**

PT. INHUTANI II is located in Pulau Laut, a small island that belongs to South Kalimantan Province. The FHM plots were established according to Buffer Zone, which was logged in 1978 (clusters 1 and 7), Biodiversity Conservation area (cluster 2), Dipterocarp (*Shorea polyandra*) Plantation (cluster 3) and Dipterocarp Seed Production Areas (clusters 4, 5, and 6). The soil order falls into Oxisols and Ultisols. Some physical and chemical nature of the soil are moderately fine (topsoil) and fine (subsoil), shallow to very shallow, high exchangeable Ca and Mg, medium to high exchangeable K, low exchangeable Na, low to medium CEC, acid to slightly acid, and low Al saturation.

The climate in the study sites, according to Schmidt and Ferguson classification, falls into type A with annual rainfall ranges from 2,429 to 2,492 mm. The rainy season occurs in December to June with monthly rainfall average of more than 250 mm. Meanwhile, the dry season occurs in July to November with monthly rainfall average of 150 mm.

### **2.2.3. Perum Perhutani Unit II**

Perum Perhutani Unit II is located in East Java Province and FHM plots were established in a sengon (*Paraserianthes falcataria*) Plantation forest, which is situated about 30 km from Kediri city going to the east. There were 5 clusters established to represent the planting years of 1992, 1993, 1994, 1995, and 1996 as cluster 2, 4, 1, 5 and 3 respectively. The soil order falls into Ultisols. Some important physical and chemical nature of the soil are moderately coarse (topsoil) and moderately fine (subsoil), thick to very thick, low exchangeable Ca, low exchangeable Mg, low to medium exchangeable K, low exchangeable Na, very low to low CEC, strong acid in soil reaction, and low Al saturation.

The study site is located at about 200 m above sea level, and receive average rainfall of 1500 mm with air temperature ranging from 22 – 32 ° C and relative humidity ranging from 50 – 70%. The climate in the study site, according to Schmidt and Ferguson classification, falls into type B.

### 2.3. Time of data collection

To know the change of crown condition, a cluster plot should be visited twice to assess the crown in the same season of different years. Meanwhile to know a trend of crown conditions, a cluster plot should be visited three times to assess the crown conditions in the same season of different years. When a plot has just been established, measurement (Mt.) was then carried out for most parameters, however, in some cases due to an avoidable reason, crown conditions were assessed in the same season of following year. The following Table 1 contains the years in which crown conditions of each plot were assessed.

Table 1. The years in which assessment on trees crown conditions in each plot were carried out

Study Site	Cluster	Plot estab.	Year of Measurement															
			1997				1998				1999				2000			
			CDm	LCr	CDn + FTr	DBk	CDm	LCr	CDn + FTr	DBk	CDm	LCr	CDn + FTr	DBk	CDm	LCr	CDn + FTr	DBk
Jambi	1	96	v	v	v	v	v	-	v	v	v	v	v	v	v	v	v	v
	2	96	v	v	v	v	v	-	v	v	v	v	v	v	v	v	v	v
	3	97	v	y	v	v	v	-	v	v	v	v	v	v	v	v	v	v
	4	98					v	v	v	v	v	v	v	v	v	v	v	v
P. Laut	1	96	v	v	v	v	-	-	v	v	v	v	v	v	v	v	v	v
	2	96	v	v	v	v	-	-	v	v	v	v	v	v	v	v	v	v
	3	96	-	-	-	-	v	v	v	v	v	v	v	v	v	v	v	v
	4	96	v	v	v	v	-	-	v	v	v	v	v	v	v	v	v	v
	5	96	v	v	v	v	-	-	v	v	v	v	v	v	v	v	v	v
	6	96	v	v	v	v	-	-	v	v	v	v	v	v	v	v	v	v
	7	96	v	v	v	v	-	-	v	v	v	v	v	v	v	v	v	v
Kediri	1	99									v	v	v	v	v	v	v	v
	2	99									v	v	v	v	v	v	v	v
	3	99									v	v	v	v	v	v	v	v
	4	99									v	v	v	v	v	v	v	v
	5	99									v	v	v	v	v	v	v	v

Note : CDm : Crown Diameter ; LCr : Live Crown Ratio ; CDn : Crown Density  
 FTr : Foliage Transparency ; CDb : Crown Dieback  
 v : measured ; - : not measured

## **2.4. Procedure of data collection**

The term of crown parameters and its definition, classification and rating as well as measuring procedure applied in this study were adopted from Forest Health Monitoring Field Methods Guide (Tallent-Halsell, 1996; USDA Forest Service, 1997), except for the number of measuring trees. According to the defined method, crown conditions were assessed on all trees with DBH 10 cm up in all subplots ( $r = 7.32$  m). In INDO-FHM crown conditions were assessed on all trees with DBH 10 cm up in subplots plus all trees with DBH 20 cm up in annular plots ( $r = 17.59$  m)

The study of the crown assessment an indicator of forest health in INDO-FHM was carried out in the areas of PT Asialog, Jambi Province, PT INHUTANI II, Pulau Laut, South Kalimantan Province and Perum Perhutani, Kediri, East Java Province. Plots establishment in each study site (Figure 1) and data recording system followed the Forest Health Monitoring Field Methods Guide (International – Indonesia version) issued by Environmental Protection Agency (EPA) (USDA Forest Service, 1997) except for tree evaluation. In the standard method, crown conditions are assessed on all trees with DBH 10 cm up in sub plot ( $r = 7.32$  m), but INDO-FHM also assessed all trees with DBH 20 cm up in annular plot ( $r = 17.95$ ).

### **2.4.1. Crown parameters**

Crown assessment is directed to the following parameters:

- (a). crown diameter wide and 90 degrees, (b). live crown ratio, (c). crown density,
- (d). foliage transparency, (e). crown dieback.

### **2.4.2. Definition of crown attributes**

For the purposes of this guide, three crown areas are clearly defined: top, outer sides, and base. Three other areas also need to be defined: crown diameter, crown form, and branch.

#### **2.4.2.1. Top**

The tree top is the highest point of a standing tree. Younger trees usually have conical-shape crowns and the main terminal stem is the top. Older trees and many hardwoods have globose and flat-topped crowns, where a lateral branch is the highest point. For some measurements (live crown ratio), only the highest live branch foliage is considered, while other measurements include a dead top. Crown measurements, such as crown density, assess how much of the expected crown is present including all dead branches and snag branches (old dead branches which have lost most of the small branches and twigs, less than 1 inch [2.54 cm] diameter at the base). Crown dieback measurements concern recent branch mortality and do not include snag branches.

#### **2.4.2.2. Base**

The crown base is a horizontal line from the bottom of the lowest foliage of the obvious live crown (usually the largest branches at the crown bottom) across the trunk. Include most crown branches, but exclude epicormic shoots and straggler branches that usually do not contribute much to the tree's growth. The base of the branch may be above or below this line. If any branch larger than 1 inch (2.54 cm) in diameter at the point of trunk attachment that is within 5 ft (1.5 m) below this line, a new horizontal line and trunk intersect is established. Create a new line at the base of live foliage on that branch. Continue this evaluation process until no 1 inch (2.54 cm) diameter or greater branches are found within 5 ft (1.5 m) of the foliage of the lowest qualifying branch.

Occasionally, all original major crown branches are dead or broken and many new branches are developing. At first, before branches reach the 1 inch (2.54 cm) diameter size, the tree for this measurement has no crown. When new branches reach 1 inch (2.54 cm) in diameter, a new crown is formed. The previous obvious crown base here would be the dead branches, while many of the live branches with foliage may be below this point. The recommendation is to find the line for the lowest live branch (1 inch diameter [2.54 cm] or larger) that meet the 5 ft (1.5 m) rule. These situations are likely to occur in areas of heavy thinning, commercial clear cuts, and severe weather damage.

#### **2.4.2.3. Sides of the crown**

Most measurements consider the crown in a two dimensional perspective, the way it would appear when reflected in a mirror. The side boundaries are limited by a line drawn from branch tip to branch tip, except when branches are widely separated. For the purpose of foliage abundance (foliage transparency), the line would encircle each separated branch. For crown density, the perimeter is drawn from branch tip to branch tip, and open spaces become part of the crown density measurement. Occasionally a branch may protrude abnormally. The lateral crown line should not be drawn to include this branch. It would not give an accurate picture of density for the tree. Draw the outline for density to include the "normally foliated" portion of the crown in this case.

#### **2.4.2.4. Crown diameter**

Crown diameter is the average of two diameter measurements: 1) widest distance anywhere in the crown between two live branches (the drip line); 2) the perpendicular distance to the widest measurements. Abnormally long branches sticking out beyond the edge of the crown are not used in establishing the extent of a crown.

#### **2.4.2.5. Crown shape**

Crown shape is a silhouette of an average open-grown tree. Usually, silhouettes are derived from vigorously growing trees and tend to be specific to a species. With

age, tree crown tends to flatten out. Crown shapes are important when measuring crown density and will be used in the future with tree height, live crown ratio, crown density, and crown diameter to estimate crown biomass. Crown shape is used as an outline for the sides of the tree, and voids of branches are considered as a loss in density for this measurement.

#### 2.4.2.6. Branch

A live branch is any woody lateral growth supporting foliage and larger than 1-inch at the base just above the swelling where it joints the main stem. Dead branches have no minimum size to be included for crown dieback estimates. Dead branches below the live crown are not included in crown dieback. Dead upper crown branches without twigs (branches less than 1-inch in diameter) are considered as old dead, or snag branches, and are not included in crown dieback estimates, but are included in crown density estimates. Secondary growths, less than 1-inch in diameter, such as water sprouts, suckers, or epicormics, are excluded from the branch definition. After a sudden release or damage, a tree may have very dense foliage, but by definition no crown. These situations are coded as follows : live crown ratio – 00, crown density – 00, crown diameter (wide and 90 degrees) – 00, crown dieback – 99, and foliage transparency – 99 (Table 2).

#### 2.4.3. Codes on Portable Data Recorder

Table 2. Crown diameter codes

Code	Definition
00	Epicormic branches only
01	< 0.15 m
02	0.16 to 0.25 m
03	0.26 to 0.35 m
...	...
99	> 99.6 m

Table 3 lists codes which should be used for live crown ratio, crown density, crown dieback, and foliage transparency.

#### 2.4.4. Equipments and supplies

Equipments used in this study were crown density – foliage transparency card and measuring tape 50 m long.



Table 3. Live crown ratio, crown density, crown dieback, and foliage transparency codes

Code	Definition	Code	Definition	Code	Definition
00	0%	35	31-35%	70	66-70%
05	1-5%	40	36-40%	75	71-75%
10	6-10%	45	41-45%	80	76-80%
15	11-15%	50	46-50%	85	81-85%
20	16-20%	55	51-55%	90	86-90%
25	21-25%	60	56-60%	95	91-95%
30	26-30%	65	61-65%	99	96-100%

Note : Class code is the percentage of the upper limits of the class, i.e., Code 10 is 6% to 10%, etc. Also, for live crown ratio the code 00 is used for trees with epicormic branches only

#### 2.4.5. Calibration and standardization

General calibration and standardization protocols should be applied to field equipment. Purchase tape of required specifications. Tapes should be maintained in working order and do not require calibration upon confirmation of accuracy.

The crown density – foliage transparency card should be used as a training aid until crew personnel are comfortable with both ratings. White areas of the card represent skylight visible through the crown area and black areas represent some aspect of the tree. After training, use the card to calibrate the observer's eyes at the start of each day and rate those trees that do not fit into an obvious class. For crown density, hold the card so that "crown density" is right-side up ("foliage transparency" should be upside down). Use the numbers that are right- side up. Conversely, for foliage transparency, make sure that "foliage transparency" is right-side up. Crews should refer to specific crown density or foliage transparency sections for a definition of aspects that are included in the crown rating.

The back of the crown density – foliage transparency card has two uses: for crown density when a portion of the crown is missing and a general scale for estimating live crown ratio. Crews should refer to the crown density and live crown ratio sections for the use of this side of the card.

A crown grid can be used in training for crown area estimation. The crown grid was developed from similar grids used to estimate areas on maps. The area does not represent a quantitative unit since the grid is intended to determine proportions. The central square has 100 dots, and each peripheral square has 25 dots. The grid may be copied on a transparency and mounted on thick plastic with clear cellophane tape for field use.

#### 2.4.6. Crown classification

Table 4 lists crown classification measurement quality objectives.

Table 4. Crown classification measurement and quality objectives

Variables	Reporting Units	Data Quality Limits
Crown Diameter Wide <sup>1</sup>	1 ft (30 cm)	90% @ ± 5 ft (1.5 m) or ±10% of the mean (whichever is larger)
Crown Diameter 90 Degrees <sup>1</sup>	1 ft (30 cm)	90% @ ± 5 ft (1.5 m) or ±10% of the mean (whichever is larger)
Live Crown Ratio	21 classes	90% @ ± 10% (2 classes)
Crown Density	21 classes	90% @ ± 10% (2 classes)
Crown Dieback	21 classes	90% @ ± 10% (2 classes)
Foliage	21 classes	90% @ ± 10% (2 classes)
Transparency	21 classes	90% @ ± 10% (2 classes)

<sup>1</sup> Evaluated as the difference between the mean of the 2 crown diameter measurements.

#### 2.4.7. Crown rating precautions

The following areas show where crown indicators could be difficult to evaluate and crews must be especially careful: The crews must attempt to stay at least 1/2 to 1 tree length from trees. Some ratings change with proximity to the tree. In some situations, it is impossible to satisfy this step, so the crew should try to do the best in each case. All evaluations are to be made at grade (same elevation as base of the tree) or up slope from the tree being evaluated. This may not be possible in all cases but never get in the habit of evaluating trees from the down slope side.

Crew should evaluate trees from an angle to each other, striving to obtain the best view of the crown. The ideal positions are at 90 degrees to each other on flat terrain. If possible, never evaluate the tree from the same position or at 180 degrees. In a forest, getting a good perspective of the crown becomes difficult. Overlapping branches, background trees, and lack of a good viewing area can cause problems when rating some trees. Crews need to move laterally to search for a good view. Take special care when rating such tree.

Cloudy or overcast skies, fog, rain, and poor sun angles may affect estimates. Live crown ratio and crown diameters may be affected but to a lesser degree than other crown indicators. Crown density tends to be overestimated because light does not project well through the foliage or, in some cases, the light may be too bright for a good estimate. Crown dieback may be underestimated because it is difficult to see dead twigs and / or to differentiate defoliated twigs from dead twigs. Foliage transparency estimates could be affected in either direction because it is hard to discern foliage from branches. The expected data quality standard is very helpful for the crews due to the limited error of normally ± 10 percent, even in poor weather conditions. However, crews need to be especially careful during poor lighting conditions. Crews should move around a tree to get another view, even if the view appears adequate as a specific location.

During heavy defoliation crown dieback may be overestimated and foliage transparency may be underestimated due to the difficulty in differentiating dead twigs

from defoliated twigs. The use of binoculars may help in separating dead twigs from defoliated twigs.

Leaning trees cause a major problem in estimating crown variables. Record crown variables as best as possible for the tree as it actually occurs rather than as it might appear if standing upright and also record in the PDR tree note field that it is leaning. This will allow for better data interpretation.

#### **2.4.8. Trees 10 cm DBH and larger crown evaluation procedures**

Crown indicators are designed to work together. Each indicator comprises a piece of information that can be used individually or as a factor in combination with other indicators.

Live crown ratio is a measure of crown length and its relationship to total tree height. Trees with higher live crown ratios are typically viewed as healthier and faster growing. Crown diameters measure crown width. Wider crowns are often associated with faster growing trees. Once the live crown ratio and crown diameter are determined, the next logical step is to measure how much of a crown exists. Crown density, which includes foliage, branches, and reproductive structures, measures the crown biomass. Crown dieback defines how much of the crown does not have foliage but has fine twigs, indicating a loss of vigor or growth potential. Foliage transparency estimates how dense the foliage is on branches, indicating stress due to foliar damage or defoliation.

Some individuals want to know why both crown density and foliage transparency are determined when they seem to be inverse measures. This is true on trees having a full crown, with no crown dieback, and no open areas in the crown. However, the average tree does not have a full, uniform crown. For example, a tree with 80 percent crown dieback could have few living branches with a foliage transparency rating of 5 percent, but the crown density rating would be 15 percent. (Crown density rating considers a normal, forest-grown crown form and then makes an estimate of how much is present on the tally tree. Foliage transparency rating considers the foliated part of the crown only).

All of these indicators have been combined into a model called the Visual Crown Rating Model. Each indicator adds to the overall rating given each tree. It is important to realize that the model is designed to rate trees on how they look, from thriving to almost dead.

#### **2.4.9. Crown diameter measurements**

A tree widest crown measurement (crown diameter wide), if viewed from the air, is the diameter of a circle including all foliage. Measure it at the crown widest point with a tape by having one observer stand under the drip line at the crown's edge, opposite an observer at the other side of the crown. Make the second measurement at 90 degrees

to the crown diameter at the widest point (crown diameter 90 degrees) using the same procedures (see annex 3).

Determine drip line ends points by looking up perpendicular to the tape and projecting where crown edge branches would hit the ground if they fell. Occasionally, a branch may protrude abnormally, but the lateral crown line is drawn across the portion of the branch which includes the "normal outline" of the tree. It is helpful to use a device, such as a clinometer, that allows the observer to measure a line perpendicular to the ground. The device should be used for training and to check estimates made during the operational field season. If you cannot see the crown edge from the drip line, both observers should move an equal distance from the tree and project the crown for an estimate. All measurements are rounded to the nearest meter.

#### **2.4.10. Live crown ratio assessment**

Live crown ratio is the percentage of total tree height supporting live foliage that is effectively contributing to tree growth. Live crown ratio is determined by the ratio of live crown length to total live tree height (Annex 1). Live crown length is determined from the crown top with the last live branch (dieback in the upper portion of the crown is not part of the live crown) to the obvious live crown base. Many times there are additional live branches below the obvious live crown. These branches are only included if they have a basal diameter greater than 1 inch (2.54 cm) and are within 5 ft (1.5 m) of the base of the obvious live crown. The live crown base becomes that point on the main bole perpendicular to the lowest foliage on the last branch that is included in the live crown. The live crown base is determined by the foliage and not by the point where a branch intersects with the main bole. It is advisable that live crown ratio is measured by two persons.

Individuals step back about 1/2 to 1 tree length from the base of the tree and move side ways at least 10 ft (3 m) to obtain a good view of the crown. An individual can use the live crown ratio scale on the back of the crown density – foliage transparency card to help in estimating ratios. To use the scale, hold the card in one hand and move the card closer or farther from your eye until the 0 is at the live top of the tree and the 99 is at the base of the tree (ground). Then place your finger at the base of the live crown. The number on the scale provides the live crown ratio. Interpolate to the nearest 5% if the point is between two values on the scale. A clinometer can also be used to verify the live crown ratio by determining the values of both heights and determining the ratio of the two values. This is very useful during training but is not necessary under field conditions.

When the two individuals disagree with their estimates, they should discuss the reasons for their ratings. Either an individual will change his or her estimate, or the two ratings will be averaged and the class recorded. The estimate is placed into one of 21

percentage classes. Codes are structured to the nearest 5 percent to be consistent throughout this guide with other procedures and to allow estimator flexibility.

#### **2.4.11. Crown density assessment**

Crown density estimates the tree crown condition in relation to a normal, healthy, forest tree and also serves as an indicator of expected growth in the near future. Crown density is the amount of crown branches, foliage, and reproductive structures that blocks light visibility through the crown. Each tree species has a normal crown that varies with the site, genetics, tree damage, etc. Higher crown density estimates are indicative of faster growth, while lower crown density measures indicate slower growth.

It is advisable that crown density rating is measured by two persons. Individuals should stand about 1/2 to 1 tree length away from the tree and move sideways at least 10 ft (3 m) to obtain a good view of the crown. To determine the crown outline, select the point on the stem used for live crown ratio and project a normal crown for that tree. Foliage below the crown base is not included in the crown (Annex 2). Project half-sided trees as full crowns, and include crown dieback and open area in this outline. In many cases, portions of the tree outline may not be complete, i.e., half-sided trees, and in these situations it may be easier to determine the percent of the tree missing and the crown density of the tree remaining portion. Then use the table on the back of the crown density–foliage transparency card to arrive at the final crown density for that tree.

After determining the outline, each person should hold the crown density – foliage transparency card along the line of sight and estimate what percentage of the outlined area is blocking sunlight. If individuals disagree on a rating, discuss and adjust it as needed. In most cases, two scores can be averaged. The two individuals may try to change places if their difference is greater than 10 percent or two classes.

#### **2.4.12. Crown dieback assessment**

Crown dieback is defined as branch mortality which begins at the terminal portion of a branch and proceeds toward the trunk and/or the base of the live crown. When whole branches are dead in the upper crown, without obvious signs of damage such as breaks or animal injury, assume that the branches died from the terminal down. Snag branches without smaller branches, 1 inch (2.54 cm) or less in diameter at the base, will not be considered as part of the crown. Dead branches in the lower portion of the crown are assumed to have died from competition and shading and are not considered as part of crown dieback, unless most of the branches above that point are dead.

Estimate crown dieback in 5 percent classes, based on the whole crown present at the time of observation. The crown base should be the same position that is used for

the live crown ration estimate. Assume that the perimeter of the crown is a two-dimensional outline from branch-tip to branch-tip.

It is advisable that crown dieback rating is obtained by two persons. Individuals should step back about 1/2 to 1 tree length from the tree base and move sideways at least 10 ft (3 m) to obtain a good view of the crown. Binoculars should be used to assist in the data collection. Observers should be conscious of lighting conditions and how they affect the day observation. Under limited-light conditions, observers should take extra time because poor lighting can make the measurement more difficult.

First, each individual should mentally draw a two-dimensional crown outline. Second, block in the affected area. Third, the proportion of the affected area should be estimated in 5 percent classes and recorded. When individuals disagree on a rating, they should discuss the reasons for their rating. Either an individual will change his or her estimate or the ratings should be averaged and the class of the estimate recorded. Differences may be due to differences in crown conditions, the estimate of the individual, or both.

#### **2.4.13. Foliage transparency assessment**

Foliage transparency is defined as the amount of skylight visible through the live, normally foliated portion of the crown or branch. Each tree species has a normal range of foliage transparency. Changes in foliage transparency occur as a result of current damage, frequently referred to as defoliation or from reduced foliage resulting from stresses during preceding years.

Estimate foliage transparency in 5 percent classes based on the live, normally foliated portion of the crown and branches using the crown density – foliage transparency card. Dead branches, crown dieback and missing branches or areas where foliage is expected to be missing are deleted from the estimate.

Large uniform crowns are rated as if the whole crown should be foliated. When defoliation is severe, branches alone will screen the light, but the individuals should exclude the branches from foliage and rate the area as if the light was penetrating. For example, an almost completely defoliated dense spruce may have less than 20 percent skylight coming through the crown, but it will be rated as highly transparent because of the missing foliage. Old trees, and some hardwood species, have crown characteristics with densely foliated branches which are spaced far apart in the crown. These spaces between branches should not be included in the foliage transparency rating. When foliage transparency in one part of the crown differs from another part, the average foliage transparency is estimated and recorded.

It is advisable that foliage transparency should be rated by two persons. Individuals should step back about 1/2 to 1 tree length from the tree base and move

sideways at least 10 ft (3 m) to obtain a good view of the crown. First, each individual will mentally draw a two-dimensional crown outline (Annex 2). Second, the foliated area will be blocked into the crown outline. Third, estimate and record the transparency of the foliated area in 5 percent classes.

When individuals disagree on a rating, they should discuss the reasons for their rating. Either an individual will change his or her estimate or the rating should be 0 averaged and the class of the estimate recorded. Differences may be due to differences in crown conditions, the estimate of the individual, or both.

## **2.5. Application of the method**

Applicability of the method was tested through four years field work and 7 batches of FHM training course within 5 years. Common problems and difficulties as well as comments during field study and training courses were recorded.

## **2.6. Data analyses**

The quantitative data of crown parameters were tested on its distribution pattern. A series of data collection from season to season in different years was aimed at knowing the status, changes and trends of crown conditions of trees representing the forest stand to indicate forest tree health. As crown conditions which were assessed through 5 parameters was considered complicated data, a simplification was made by aggregating the closely related parameters (Cline-Steven, 1995). Common probability value test procedure was applied to make the gathered data easier to be interpreted.

# **III. RESULTS AND DISCUSSIONS**

## **3.1. Relevancy of crown in a living plant system**

### **3.1.1. Role of leaf in a living plant system**

Plants uptake minerals and absorb water from the soil through diffusion process at the root system. Capillary pressure permits water and soluble minerals to be translocated through the xylem vessels throughout the upper parts of the plant. Such materials in the leaf are then used for further physiological processes and growing component. However, such growing component will not be valuable to the plants till net photosynthate is available.

Photosynthate in the form of carbohydrates is the output of the complex process of photosynthesis. Photosynthesis will only take place in the chloroplast when carbon-dioxide and water molecules are available in the cells and solar radiation as an energy has been captured by chlorophyll in the same cells. Carbon dioxides are obtained from the air through the complex process of respiration where stomata is in the open or close

position during the day when appropriate solar radiation reaches the living leaves. Chlorophyll is the only cell organelle which is capable capturing solar radiation for a photosynthesis process. Chlorophylls are only found in leaves and shoots. Therefore leaves and shoots are very essential component of living crown of plants.

### 3.1.2. Crown diameter and Live crown ratio

A greater crown with large number of active mature leaves produce more photosynthate than the small one. Since photosynthate play very important role in plant growth therefore the size of crown may affect the productivity in the long run. The size of crown is reflected by two crown parameters namely crown diameter (CDm) and life crown ratio (LCr). The CDm and LCr represent horizontal and vertical size of crown, respectively. CDm of a tree crown was expressed in the actual length (in meter). Meanwhile LCr was expressed in a figure representing the percentage of vertical crown length to the tree height. The bigger size and the higher score of both parameters indicate higher potential role in supporting growth process. The lower figure of LCr indicates lower vigor class. It was believed that if LCr is equal to 1/3, a mature tree class falls into a normal vigor (Kozlowski, T.T. 1962).

In photosynthesis process, the quantity of the product is equal to raw materials. In other words, the quantity of product much depends on the number of raw materials. However, the capacity in accommodating large number of the raw materials very much depend on the quantity of active mature leaves or the size of crown. Therefore, the size of mature leaves bearing crown may play important role in the growing process of a forest tree, the larger the size, the higher its potential role.

Using data collected on the year 1999 from clusters 1 and 7 (natural forest, Pulau Laut), cluster 3 (plantation forest, Pulau Laut) and cluster 2 (natural forest, Jambi), Pearson correlation test was applied to know if crown diameter has correlation to the basal area. Based on level of disturbance, the 4 selected clusters were considered to be relatively less disturbed than the others. It was then proven, forest tree crown diameter has positive correlation to the basal area (Table 5). The high and very low of correlation value  $r$  and probability, respectively, indicated that crown diameter was significantly correlated to basal area. Such result of the test indicates that crown diameter may reflect the size of basal area. Therefore, both crown diameter and stem diameter in a detection and monitoring program are complementary data. It was also proved, using data collected from overlaid FHM plots on NFI plots in South Kalimantan, crown parameters have positive correlation, even not very strong, to basal area (Kasno, *et al.* 2001). Such complementary parameters, in a case of limited facility, one may apply one of the parameters instead of using both.



Table 5. Pearson's correlation between trees basal area and crown diameter, 1999

No. Location Parameter			CDWd		CD90		CDm		Crown Area	
			r	prob	R	Prob	r	prob	r	prob
1.	Jambi Cluster 2	Diameter Basal Area	0.69	0.0001	0.67	0.0001	0.69	0.0001	0.69	0.0001
2.	P. Laut Cluster 1	Diameter Basal Area	0.86	0.0001	0.83	0.0001	0.87	0.0001	0.84	0.0001
3.	P. Laut Cluster 3	Diameter Basal Area	0.61	0.0001	0.68	0.0001	0.68	0.0001	0.71	0.0001
4.	P. Laut Cluster 7	Diameter Basal Area	0.84	0.0001	0.82	0.0001	0.86	0.0001	0.78	0.0001

### 3.1.3. Foliage transparency and crown density

Foliage transparency (FTr) score indicates that the light proportion penetrate into forest floor through foliage space of a tree. The higher FTr score of a tree, more light may pass through the foliage space and small quantity of light may be captured by the leaves. Meanwhile crown density (CDn) score indicates light proportion blocked by the present crown of a tree. The lower CDn score of a tree means more light may reach forest floor through crown space.

Ftr and CDn are two complementary crown parameters. The total score of FTr and CDn tends to indicate the normality of a tree crown shape. The maximum total of the two crown parameters is 100, the higher total score the more perfect shape. It was proven that most FTr score of common tree species in the study sites varied in a closer range than CDn. If tree crown has a missing part, the crown is then imperfect shape. Many trees under natural forest have irregular crown shape due to uneven side shade and over top from the immediate tree crowns.

When a tree crown receives external destructive stressors such as storms and felling, higher branches may cause a loss of some parts of the crown. In such case, CDn figure will be low due the missing crown. Example, the fact of low CDn due to physical damages is presented on Table 6. If the total score of FTr and CDn does not reach 100, it indicates there is a missing crown from the imagined normal crown shape. Therefore, crown density may be considered as sensitive indicator of trees suffering damages.

Various external stresses, either natural or artificial, such as falling big tree may cause a damage to its neighboring tree crowns. Under separate study it was proved that falling tree may cause a damage to crown of smaller trees (Nuhamara and Kasno, 2001; Kasno and Supriyanto, 2001). Such damage caused by felling a bigger tree may be reflected on abnormality of either crown size or shape.

Table 6. Examples damage indicating poor crown

Trees ID	Crown Score		Damage Score			Notes
	FTr	CDn	Dmg 1	Dmg 2	Dmg 3	
01.1.02/PUL	95	5	6,21,8	0,00,0		Broken apical dominance
02.1.04/PUL	85	5	6,21,2	0,00,0		Broken apical dominance
02.1.10/PUL	90	10	6,21,3	0,00,0		Broken apical dominance
02.1.11/PUL	90	10	6,21,4	0,00,0		Broken apical dominance
02.3.22/JAM	95	5	3,01,3	5,01,3	6,21,2	Cancer on lower bole, cancer on upper bole, broken apical dominance
02.3.27/JAM	95	5	6,21,2	9,31,0	0,00,0	Broken apical dominance, abnormal foliage
02.4.08/JAM	95	5	6,21,5	0,00,0		Broken apical dominance
03.1.02/JAM	80	2	6,21,2	0,00,0		Broken apical dominance
04.3.05/JAM	95	5	3,02,4	7,22,2	6,21,0	Conk /decay on lower bole, Broken branches;
07.4.12/PUL	80	20	2,03,0	6,21,3	0,00,0	Broken apical dominance Open wound on basal stem runs to lower bole, broken apical dominance

### 3.1.4. Crown dieback

Crown dieback (CDb) is defined as recent branch mortality with fine twigs which begins at the terminal portion of living branch and proceeds toward the trunk. Such symptom indicates a water translocation problem causing inadequacy of water supply on terminal portion of the crown. A serious damage on roots, trunks, twigs as well as acid rain may cause a similar symptom on the crown that is dieback. The higher score of CDb indicates poorer plant crown. As a matter of fact, during three years field study, a significant dieback symptom was rarely found in all study sites. However, the inclusion of such parameter to assess crown conditions is really reasonable. Therefore, combination of dieback with other crown variables may reflect a tree vigor.

### 3.1.5. Ecological role of crown

On one side various environmental factors, both biotic and abiotic, affect a plant crown size and quality, on the other side the crown may play an important ecological role. A great size and high density plant crown block most light and reduce its intensity, creating a shade for understory vegetation. Such great crown permits only small portion of light reaching the forest floor. The amount of light reaching forest floor may affect seedlings survival. Under separate assessment of INDO-FHM project, it was proved that

there was a positive correlation between canopy opening and LCr of saplings growing under taller tree's crown (Supriyanto and Kasno, 2001).

A greater crown may sink more carbon dioxide and accommodate more solar energy during the day and release the excessive energy during the night to keep the air temperature in the forest more or less stable (Oliver and Larson, 1990).

A greater crown size also leads most raindrops passing down through leaf to leaf and stem flow instead of hitting soil surface directly. Such crown role reduces the negative effect of raindrops in eroding top soil. Moreover a great crown, in the long run, produces a lot of litters on forest floor. The excessive litters on the forest floor slow down the surface run off and allow most rainwater penetrating into soil. Such great crown and excessive mulch inhibit water evaporation from the soil keeping top soil in moist condition. A moist condition is most favorable for decomposition process of litters.

Poor crown is believed will affect the growth and productivity of a forest tree for a long period. Beside component of tree vigor, crown plays important role in ecological aspect. However, plant crown may suffer from various mechanical, physical, chemical as well as biological stresses such as storm, drought, nutrient inadequacy and the attacks of pests and diseases. Therefore, tree crown condition as one of indicators of forest health, is suggested as substitute for refinement and revision of Criteria and Indicators for Forest Management such as developed by ITTO (1998; 1999).

In general, forest has various functions. Based on its potential function, forest areas are then classified into several groups e.g. production, protection, conservation, recreation and conversion forest. The important role of crown on growth process as well as on the environment was clearly proven.

## **3.2. Crown condition**

### **3.2.1. Size and score of crown parameter**

All crown parameters (CDm, LCr, FTr, CDn and CDb) measured annually in the same season of 1997 – 2000 in all study sites showed a similar distribution pattern, except for some poles and trees, which suffered a heavy damage. As an example, data collected in the year 2000 are presented in this section as representative of the previous pattern of each crown class parameter. The complete data can be found in Appendices 4 - 15.

#### **3.2.1.1. Crown diameter**

Figures 2 – 4 present the crown diameters of poles and trees in all study sites. Figure 2 shows the range of horizontal crown diameter (CDm) of poles (DBH = 10 to < 20 cm) and trees (DBH = 20 cm up) in the established circular plots under natural forests in the areas of PT. Asia Log (Jambi) and PT. Inhutani II (Pulau Laut). Figure 3 shows the

range of crown diameter of poles and trees (*P. falcataria*) in plantation forest of Perum Perhutani Unit II Kediri. Figure 4 presents crown diameter of dipterocarp poles and trees (*S. polyandra*) in plantation and natural forest of PT. Inhutani II, Pulau Laut.

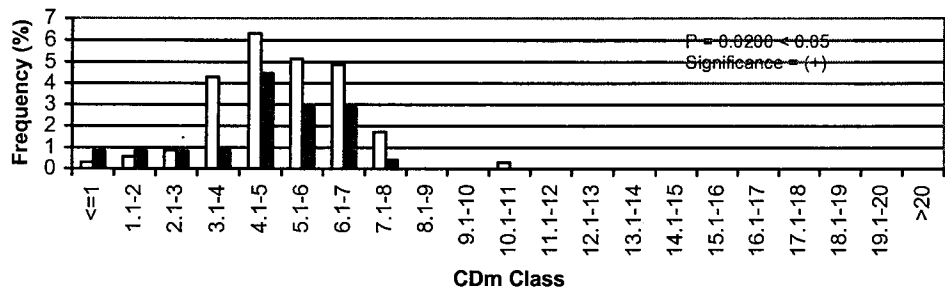

Figure 2. Distribution of poles crown diameter in natural forest in Jambi (white bar) and P. Laut (black bar), 2000

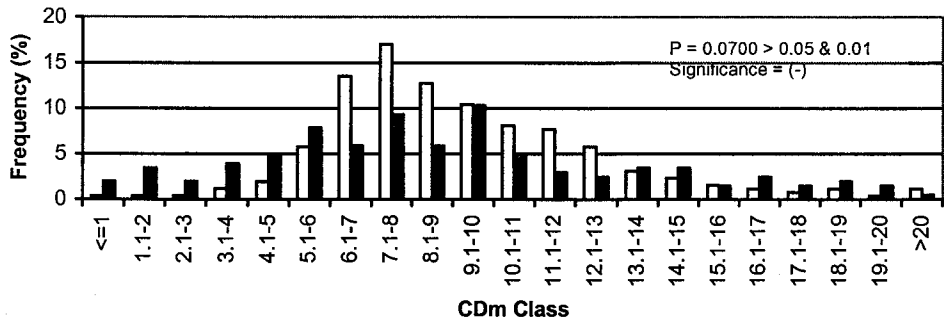

Figure 3. Distribution of trees crown diameter in natural forest in Jambi (white bar) and P. Laut (black bar), 2000

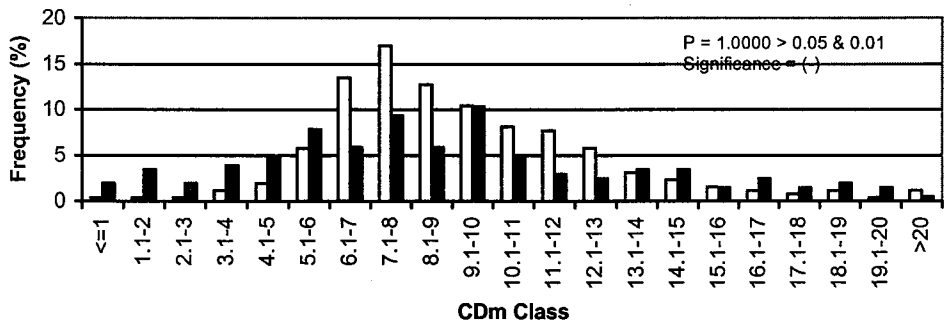

Figure 4. Distribution of poles crown diameter of *S. polyandra* in plantation (white bar) and natural forest (black bar), Pulau Laut, 2000

Figure 2 shows that pole crown diameter of common forest trees in natural forest both in Pulau Laut and Jambi varied from less than 1 m to 11 m, with high frequency having 3-7 m. FHM Plots in Jambi has more poles with smaller crown diameter than in Pulau Laut. The higher pole density in Jambi might cause shorter crown diameter than in P. Laut.

The trees CDm class distribution pattern in FHM cluster-plots in natural forest of Jambi did not differ significantly (Figure 3). *S. polyandra* in natural and plantation forest showed similar pattern of crown diameter class distribution (Figure 4). However, crown of a pole under shade tends to develop toward the immediate space with more light intensity (Oliver and Larson, 1990). Such crown of a pole tends to have irregular shape than would occur in plantation where light intensity is evenly available. According to the defined method, an irregular crown shape tends to have longer diameter than a normal shape. Therefore, crown of poles in plantation showed a closer range than in natural forest, although in this case it was not significantly different. It means that the level and pattern of shading in natural forest in Pulau Laut has not reached significant causing level.

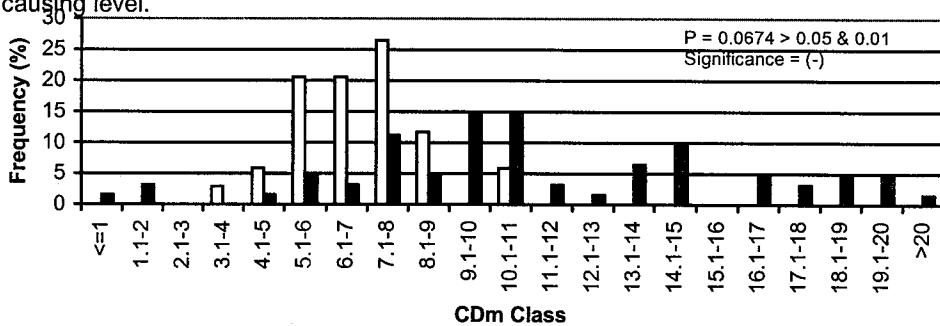

Figure 5. Distribution of crown diameter of trees of *S. polyandra* in plantation (white bar) and natural forest (black bar), Pulau Laut, 2000

### 3.2.1.2. Live Crown Ratio

The following Figures 6-9 presents distribution pattern on live crown ratio for both poles and trees in Jambi and P. Laut. Figure 6 shows that there was a significant difference between the LCr class distribution of poles in Jambi and P Laut ( $P = 0.00016 < 0.05$  and  $0.01$ ). Most of LCr in Jambi tend to have lower scores than in P. Laut. One important factor that affects the LCr score is the amount of light. Previous report shows that the value of LCr sapling has positive correlation with canopy density, the higher value of canopy density caused higher value of LCr (Supriyanto and Kasno, 2001). Suggesting that LCr value of tree under shade is affected by canopy density. It happened

that the average canopy density in Jambi was much higher (93.71 %) than in P. laut (64.42%).

Similar significant difference occurred between LCR class distribution of *S. polyandra* in natural forest and plantation. Poles of *S. polyandra* in natural forest tend to have shorter crown (vertical length) than in plantation ( $P = 0.0066 < 0.05$  and  $0.01$ ). The higher tree has higher crown position rather than poles since the poles grows under shade of tree crown.

LCr of trees in natural forest in Jambi did not differ significantly to Pulau Laut (Figure 8) and similar phenomenon was shown by *S. polyandra* tree in natural forest and plantation (Figure 9).

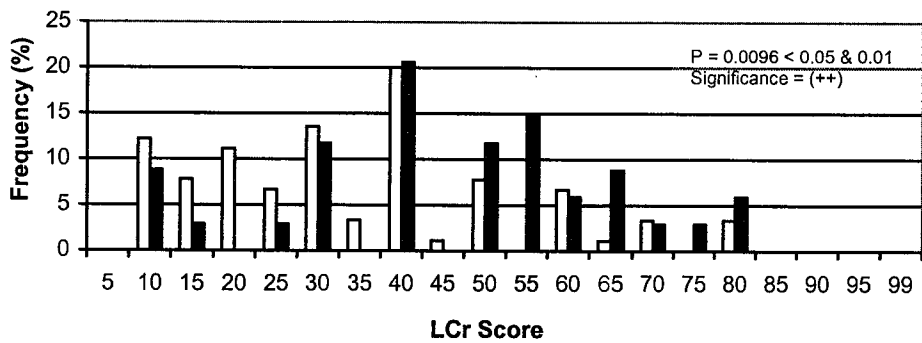

Figure 6. Score distribution pattern of pole live crown ratio in natural forest of Jambi (white bar) and P.Laut (black bar).

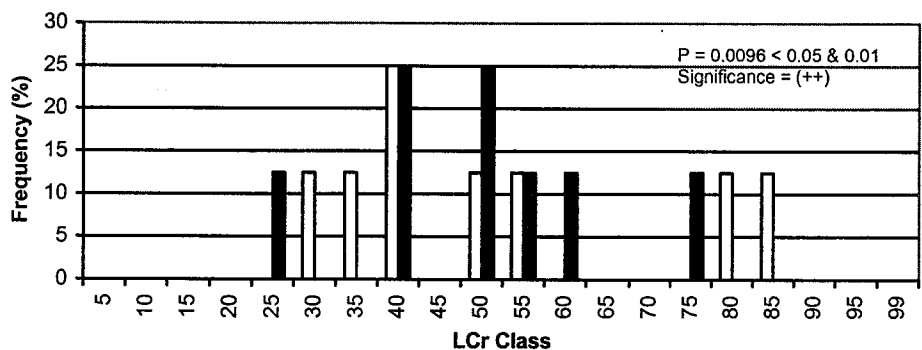

Figure 7. Score distribution pattern of pole live crown ratio of *S. polyandra* in plantation (white bar) and natural forest (black bar), Pulau Laut, 2000

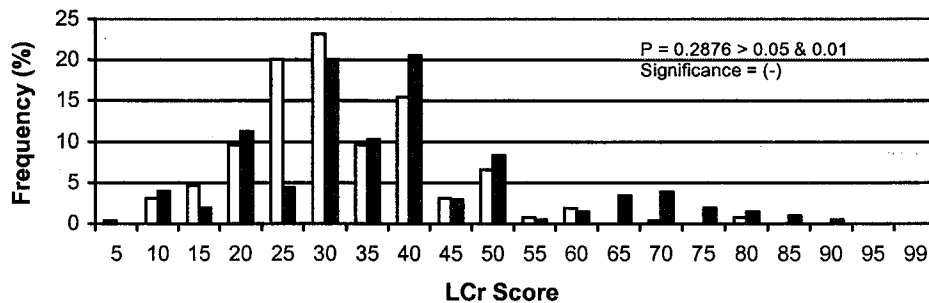

Figure 8. Score distribution pattern of tree live crown ratio in natural forest of Jambi (white bar) and P.Laut (black bar).

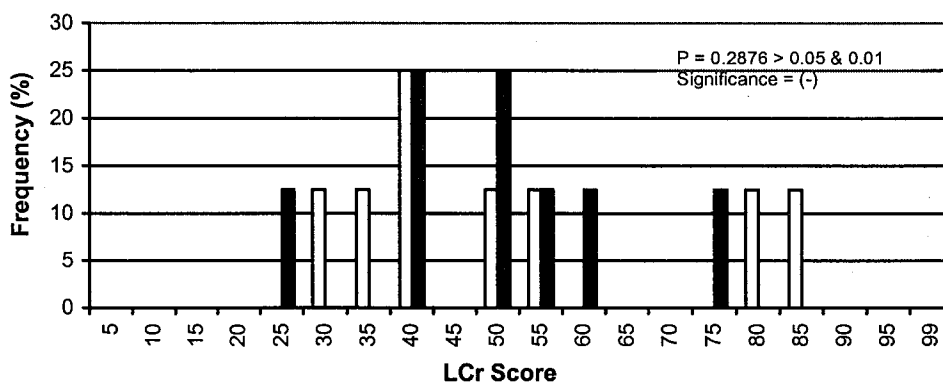

Figure 9. Score distribution of tree live crown ratio class of *S. polyandra* in plantation (white bar) and natural forest (black bar), Pulau Laut, 2000

### 3.2.1.3. Crown density

Figures 10 – 13 present CDn class distribution pattern of both poles and trees in all study sites. It is shown in Figure 10 that poles in natural forest in Jambi tend to show higher CDn scores than in Jambi. The higher score of CDn reflects a better crown shape than the lower one. This fact indicated that most canopy opening in Pulau Laut was higher than Jambi ( $p = 0.0103 < 0.05$ ). Poles under more light intensity tend to have higher score in crown density than would occur under lower light intensity.

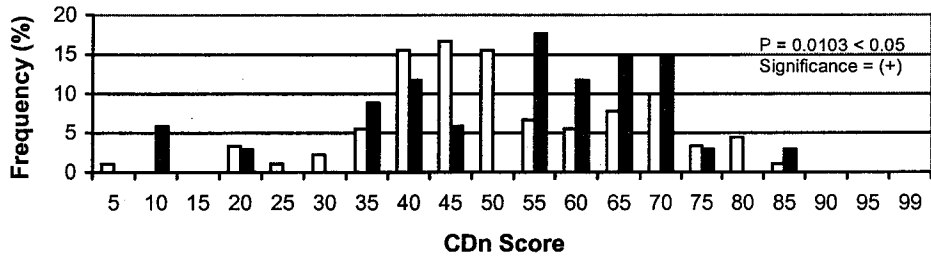

Figure 10. Score distribution pattern of pole crown density in Jambi (white bar) and Pulau Laut (black bar) natural forest.

Similarity case to Figure 10 was shown by pole crown of *S. polyandra*. ( $p = 0.0103 < 0.05$ ). Poles of dipterocarp in plantation showed lower scores than those in natural forest in Jambi (Figure 11).

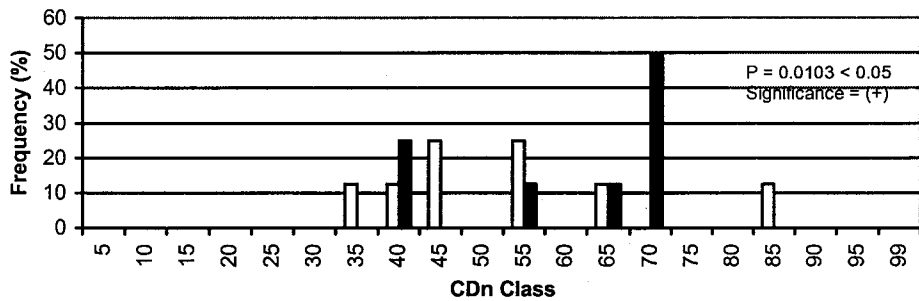

Figure 11. Score distribution pattern of pole crown density of *S. polyandra* in plantation (white bar) and natural forest (black bar), Pulau Laut, 2000

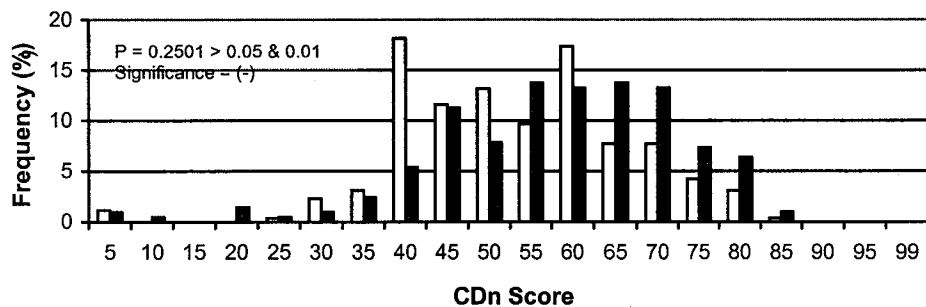

Figure 12. Score distribution pattern of tree crown density in Jambi (white bar) and P.Laut (black bar) natural forest



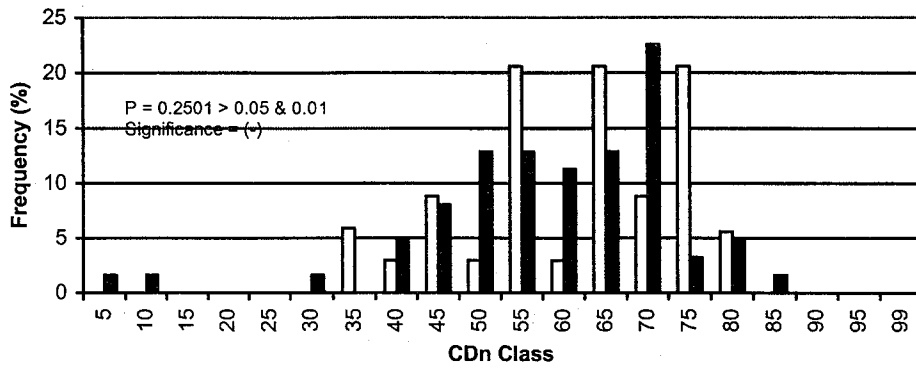

Figure 13. Distribution of Crown density of trees of *S. polyandra* in plantation (white bar) and natural forest (black bar), Pulau Laut, 2000

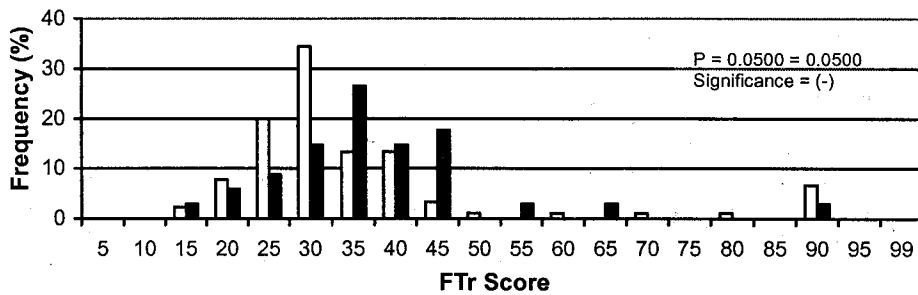

Figure 14. Score distribution pattern of pole foliage transparency in Jambi (white bar) and P.Laut (black bar) natural forest

Figure 12 shows that there was no significant difference between tree crown density of natural forest in Jambi and Pulau Laut. It indicated that there is no environmental difference, which affects crown density between Jambi natural forest and Pulau Laut. Similar case was the crown density of *S. polyandra* in Pulau Laut and foliage transparency of various tree species in natural forest in Jambi and Pulau Laut (Figures 13 - 17).

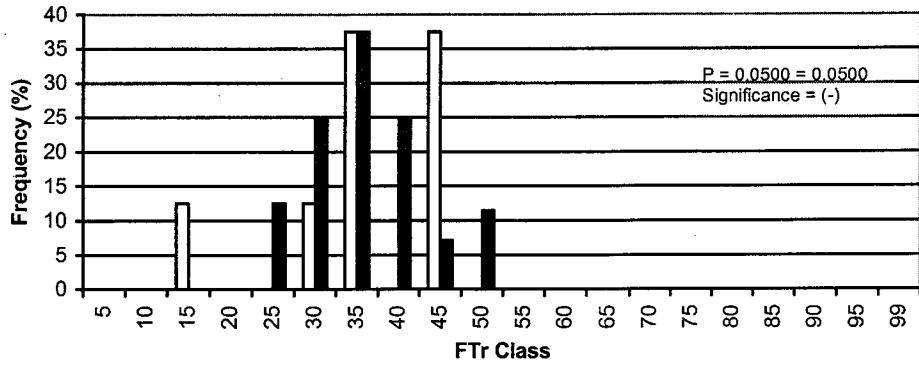

Figure 15. Distribution of foliage transparency of poles of *S. polyandra* in plantation (white bar) and natural forest (black bar), Pulau Laut, 2000

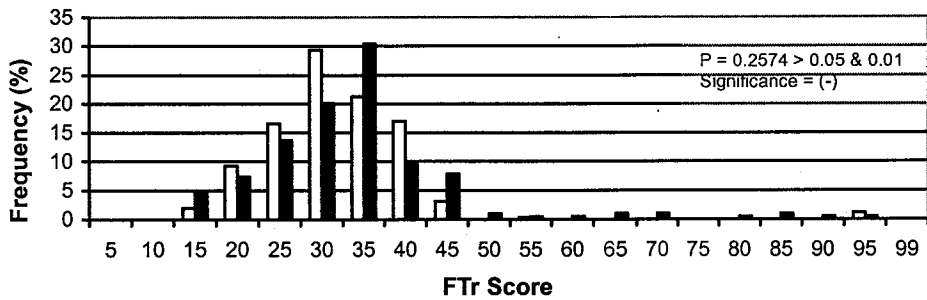

Figure 16. Score distribution pattern of foliage transparency of trees in Jambi (white bar) and P.Laut (black bar) natural forest

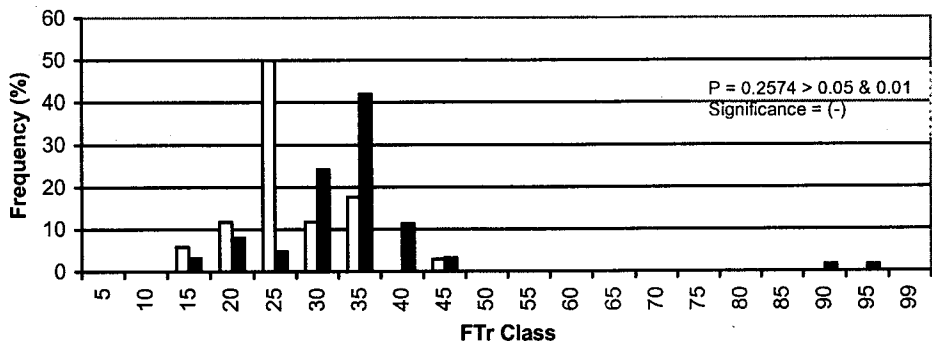

Figure 17. Distribution of foliage transparency of trees of *S. polyandra* in plantation (white bar) and natural forest (black bar), Pulau Laut, 2000

Although the range of FTr score varied from 10 – 95 but most of scores were within 25 to 40. The higher score of FTr indicates poorer crown, which the lower score the better vigor. This fact rise a question of threshold differentiates unhealthy from healthy tree. It was noted that when a tree crown is showing high score of FTr and the plant was heavily defoliated. Of the tree is not deciduous, then tree with FTr score 80 up indicates serious damage. However, such case was reflected by a very low score of CDn (see also Table 6 of the earlier section).

Dieback symptom was rare by observed on crowns of poles and trees in all established plots. It indicated that there was no significant problem in water translocation as well as acid rain in the study sites.

### 3.2.2. Changes and trends

Assessing crown condition, according to most common comments from trainees, by using 5 parameters was more time consuming and laborious than the other indicators. Why do not we use a single most appropriate crown parameter. In responding such complicated image, exercise to simplify the data was done using simplification procedure created by USDA FHM team (Cline-Steven, 1995). The following steps were the procedures of simplification from five crown variables into single variable (Figure 18). The initial step of the procedure is the calculation competition factor (CF) for every tree observed. In this exercise, due to unclear definition of distance factor, interpretation was then made to define the formula to be used in the exercise. Distance factor was then assumed to be horizontal distance (Hz) measured from plot central point to every tree position in the plot or horizontal distance divided by annular plot radius (Rd. = 17.95 m) instead of distance from a tree to the immediate polygonal tree positions. To measure such tree distance to every immediate tree position is really time consuming.

Eventually, five variables were aggregated to be a single variable called VCR (visual crown rating). It was identified the higher VCR figure the better was the tree vigor, however, VCR figure so greatly varied. The following Table 2 is an example of VCR figures. There were two VCR columns namely VCR1 and VCR2. VCR1 was obtained by using Hz as distance factor and VCR2 by using Hz/Rd. By such data, if a tree crown is periodically assessed, may indicate changes or trends. However, VCR figure does not indicate clearly what short vigor class is a tree. Therefore, a classification is needed to make it more meaningful. However, a classification may be done if the minimum and maximum figures as well as thresholds have been identified. Such requirements could not be fulfilled. However, it seems both VCR1 and VCR2 are still showing complicated figures, therefore the use of original parameters looks to be more simple. Later information indicated that VCR formula was used for the estimation of carbon sequestration instead of forest health identification (Ken Stolte, personal communication).

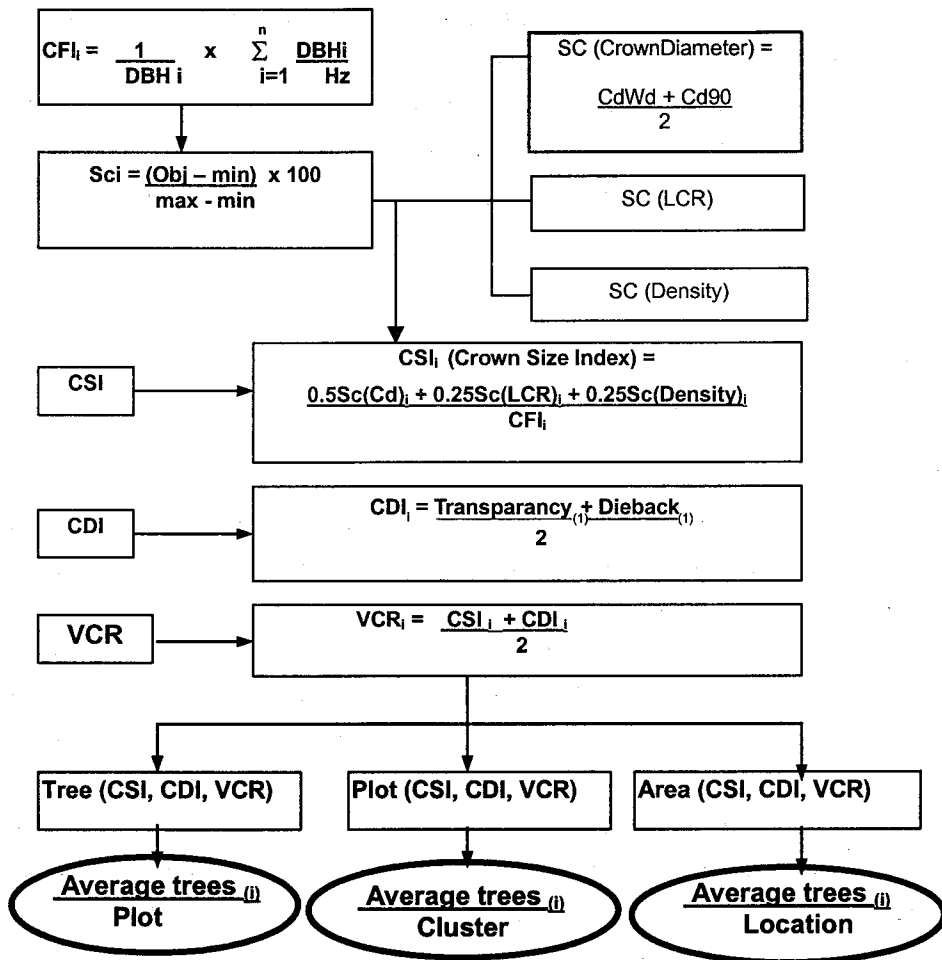

Figure 18. A crown data simplification stepping procedure in USDA FHM project

Table 2. The Value of VCR; Size and Score of VCR Determining Parameters

No	Trees ID	FHM ID	DBH	HD	LCr	CDn	Cdb	FTr	CDm	CDI	CSI	CFI	VCR1	VCR2
1	01.1.09/PUL	Diomac	64.1	915	30	55	0	35	1120	18	705.1	0.01	361.2	636,130.2
2	01.1.05/PUL	Diomac	67.7	470	30	45	0	45	1870	23	1,384.0	0.01	703.2	1,392,903.9
3	01.1.07/PUL	Litrox	59.1	640	35	50	0	40	1130	20	881.1	0.01	450.5	675,832.8
4	01.1.04/PUL	Shopol	15.3	370	55	55	0	40	505	20	4,343.2	0.05	2,181.6	1,125,733.5
5	01.1.14/PUL	Shopol	23.3	960	45	55	0	45	940	23	2,565.7	0.03	1,294.1	735,785.4
6	01.1.03/PUL	Shopol	26.9	820	40	55	0	40	945	20	1,912.6	0.03	966.3	305,865.6
7	01.1.16/PUL	Shopol	26.9	1340	75	65	0	35	720	18	4,630.6	0.03	2,324.0	1,977,618.7
8	01.1.12/PUL	Shopol	28.7	1730	40	85	0	15	175	8	1,193.5	0.03	600.5	215,881.2
9	01.1.08/PUL	Shopol	33.8	590	30	40	0	35	1045	18	1,223.3	0.02	620.4	329,920.5
10	01.1.02/PUL	Shopol	34.9	600	10	5	0	95	50	48	56.7	0.02	52.1	383,695.6
11	01.1.11/PUL	Shopol	38.7	1505	30	45	0	40	985	20	1,003.1	0.02	511.5	306,892.0
12	01.1.10/PUL	Shopol	47.8	820	30	45	0	35	930	18	764.7	0.02	391.1	223,261.6
13	01.1.17/PUL	Shopol	65.0	1205	30	55	0	40	1675	20	1,213.4	0.01	616.7	303,911.3

Table 2. (Continuation)

No	Trees ID	FHM ID	DBH	HD	LCr	CDn	CDb	FTr	CDm	CDI	CSI	CFI	VCR1	VCR2
14	01.1.13/PUL	Shopol	102.1	1030	30	50	0	40	1800	20	883.9	0.01	441.9	15,202.3
15	07.4.12/PUL	Antchi	54.2	1715	15	20	0	80	415	40	89.4	0.02	64.7	27,701.7
16	07.4.02/PUL	Diomac	25.2	60	20	60	0	35	735	18	697.5	0.03	357.5	46,659.2
17	07.4.19/PUL	Macsp1	11.6	450	50	60	0	35	495	18	4,877.1	0.07	2,447.3	69,122.1
18	07.4.05/PUL	Sanlae	45.0	325	30	45	0	35	1250	18	1,222.3	0.02	619.9	260,685.1
19	07.4.18/PUL	Shopol	10.5	528	75	40	0	35	535	18	11,862.8	0.08	5,940.1	137,744.9
20	07.4.14/PUL	Shopol	25.8	1270	90	70	0	30	535	15	6,956.8	0.03	3,485.9	139,905.9
21	07.4.08/PUL	Shopol	30.7	1745	35	70	0	20	1015	10	1,579.6	0.03	794.8	487,687.1
22	07.4.16/PUL	Shopol	31.0	1160	30	65	10	30	1045	20	1,382.2	0.03	701.1	834,141.8
23	07.4.03/PUL	Shopol	33.8	280	10	55	0	35	850	18	455.4	0.03	236.4	156,793.9
24	07.4.13/PUL	Shopol	60.9	1260	50	70	0	30	1710	15	2,135.6	0.01	1,075.3	54,808.0

The following Figures 19 - 34 show the change and trend of pole and tree crown variables during 1-3 years field study. There were small changes and little bit increasing trend on crown diameter under natural forest in Jambi (Figure 19). Some other figures (Figures 23, 24, 25, 27, 28, 29, 30, 31, 33, 34, and 35) indicated similar trends of the other crown parameters.

The size of crown diameter may relate to canopy density, the longer the crown diameter the higher is the canopy density. The increasing trend of crown diameter proved to be followed by the increasing trend of canopy density in Jambi (Figure 20, white bar). Similar fact was shown by the decreasing trend of crown diameter in Pulau Laut coinciding with the decreasing trend of canopy density (Figure 20, black bar). Such fact indicates that crown diameter is complementary to canopy density. Therefore, in the case of a limitation, one may measure crown diameter or canopy density instead of both parameters.

During three years assessment period, it was proven by most of crown parameters that the scores between the respective years were not significantly different. As growth indicator, crown diameter is the easiest to express trend amongst the other crown parameters. In fact, crown diameter showed increasing trend during three years assessment period, however, the increase from year 1 to year 3 is not significantly different. To reach a distinct difference from measurement 1 to the successive measurement needs longer assessment period, probably 5 years will be appropriate.

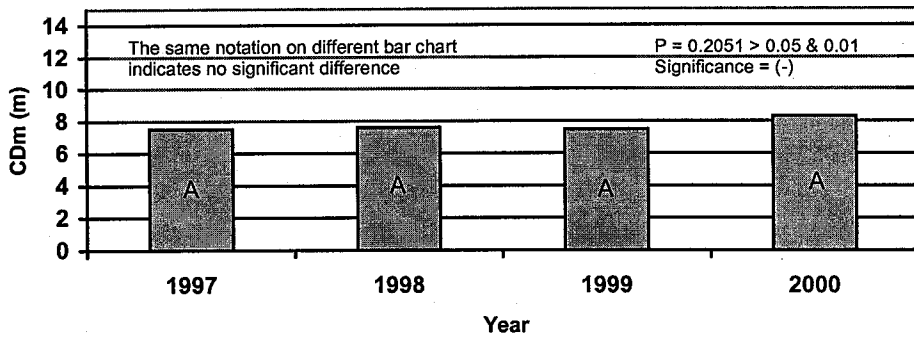

Figure 19. Change on crown diameter within the different year in Jambi natural forest, 1996 – 2000

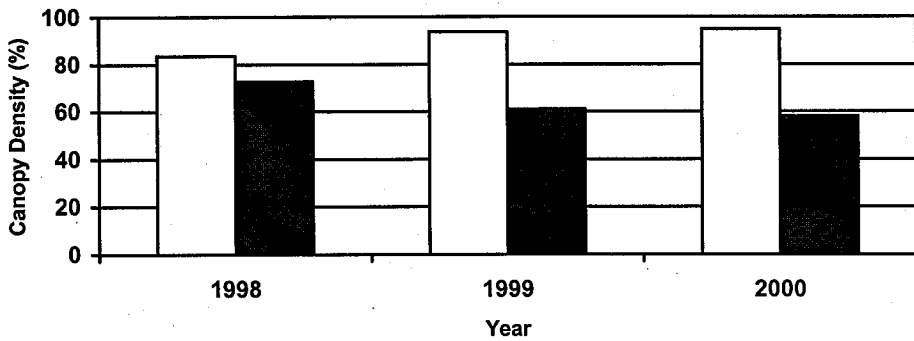

Figure 20. Canopy density on FHM cluster-plots in Pulau Laut (black bar) and in Jambi (white bar)

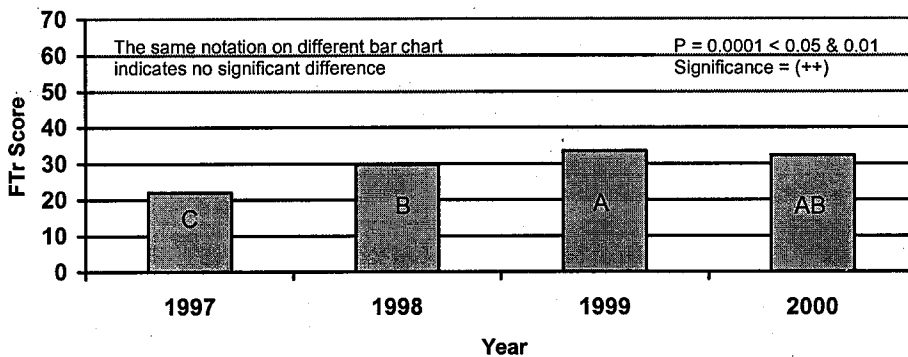

Figure 21. Change on foliage transparency within the different year in Jambi Natural Forest, 1996 - 2000

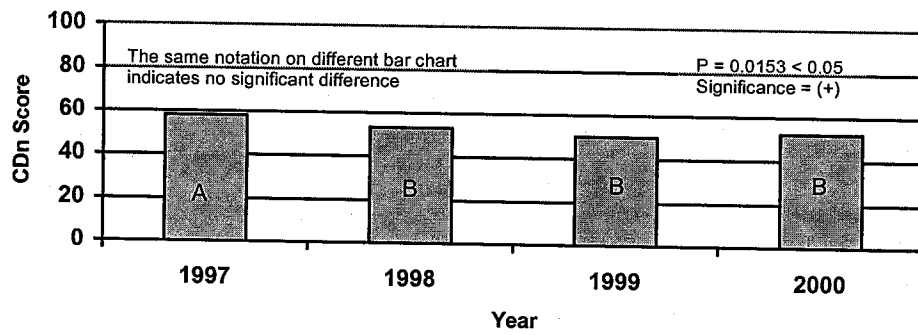

Figure 22. Change on crown density within the different year in Jambi, Natural Forest, 1996 – 2000

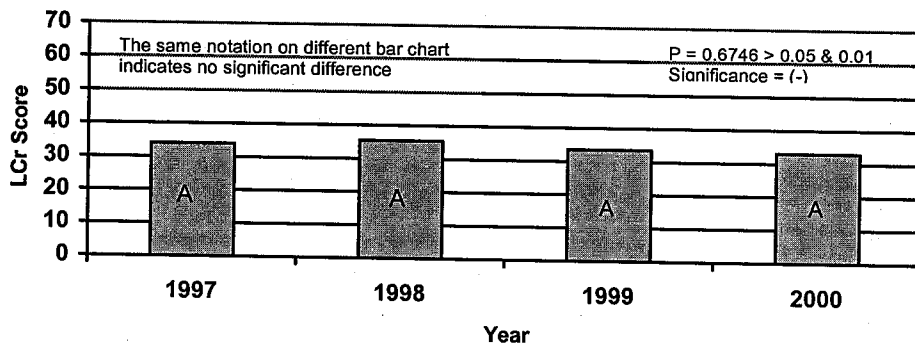

Figure 23. Change on live crown ratio within the different year in Jambi, Natural Forest, 1996 - 2000

#### Change on crown condition of forest trees, Pulau Laut

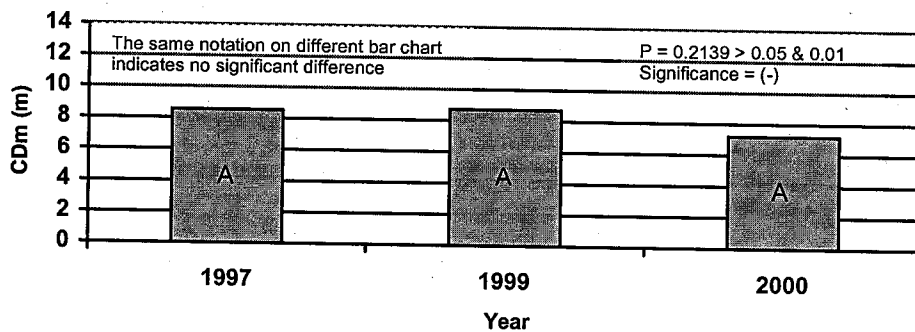

Figure 24. Change on crown diameter within the different year in Pulau Laut, Natural Forest, 1997 - 2000

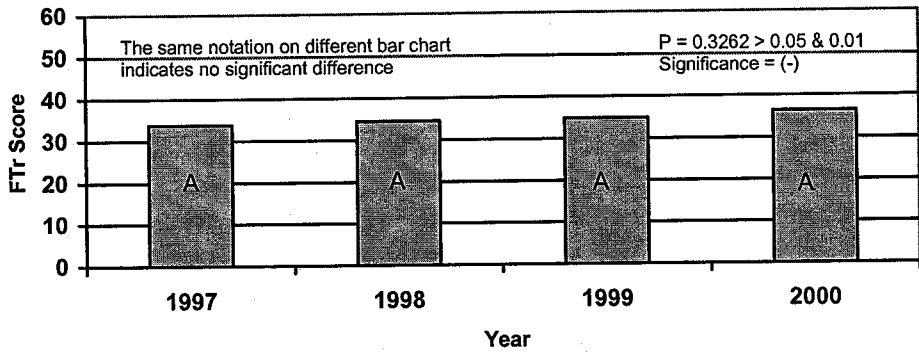

Figure 25. Change on foliage transparency within the different year in Pulau Laut, Natural Forest, 1997 - 2000

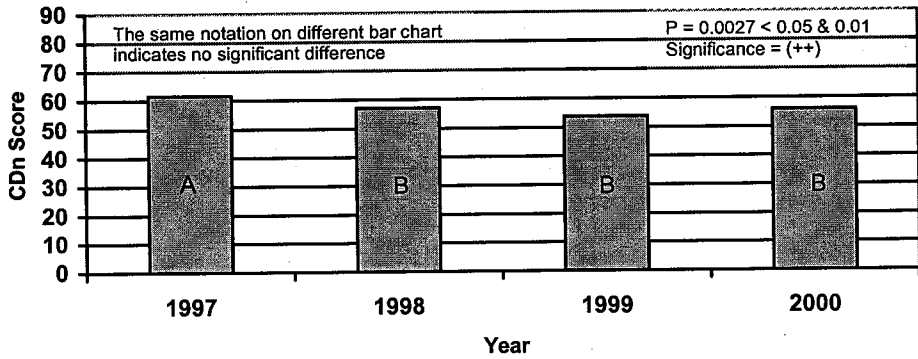

Figure 26. Change on crown density within the different year in Pulau Laut, Natural Forest, 1997 - 2000

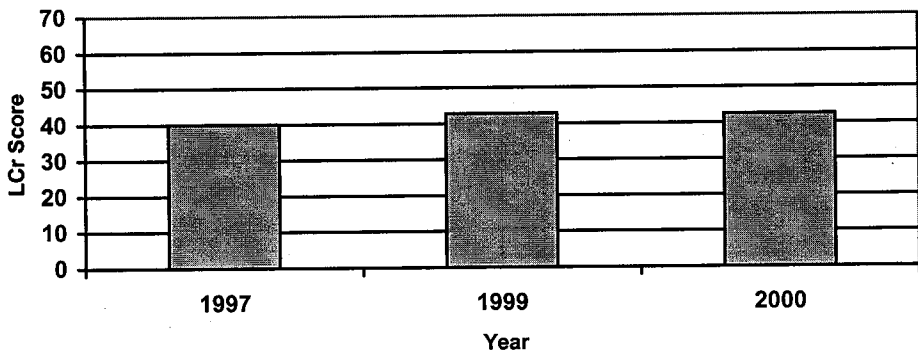

Figure 27. Change on live crown ratio within the different year in Pulau Laut, Natural Forest, 1997 - 2000



Change on crown condition of *S. polyandra* plantation, Pulau Laut

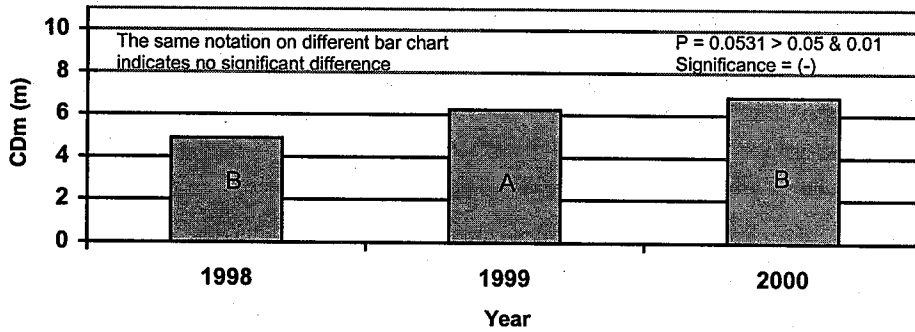

Figure 28. Change on crown diameter within the different year in *S. polyandra* plantation, Pulau Laut, 1998 - 2000

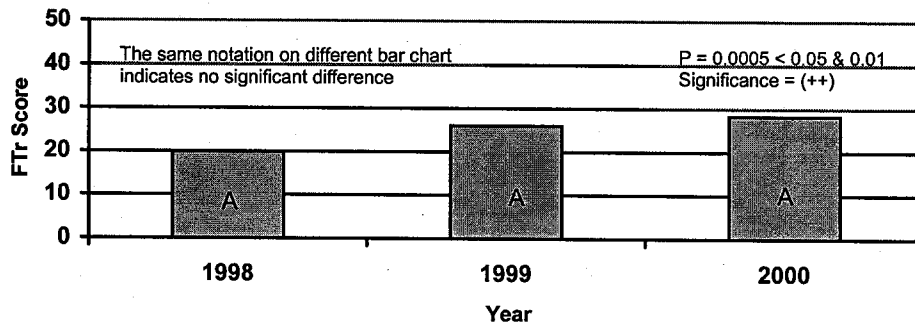

Figure 29. Change on foliage transparency within the different year in *S. polyandra* plantation, Pulau Laut, 1998 - 2000

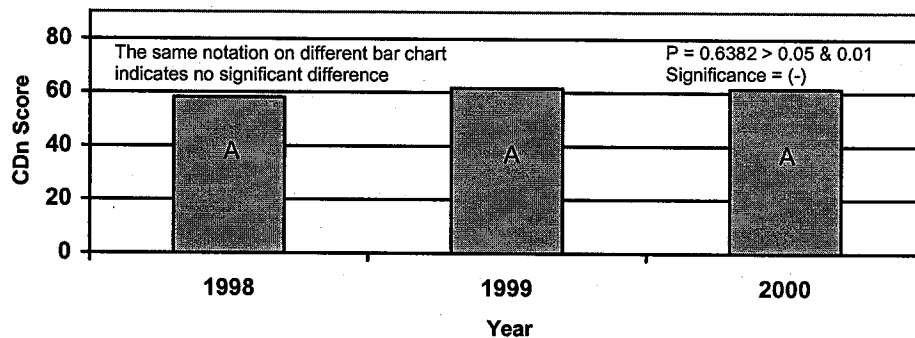

Figure 30. Change on crown density within the different year in *S. polyandra* plantation, Pulau Laut, 1998 - 2000

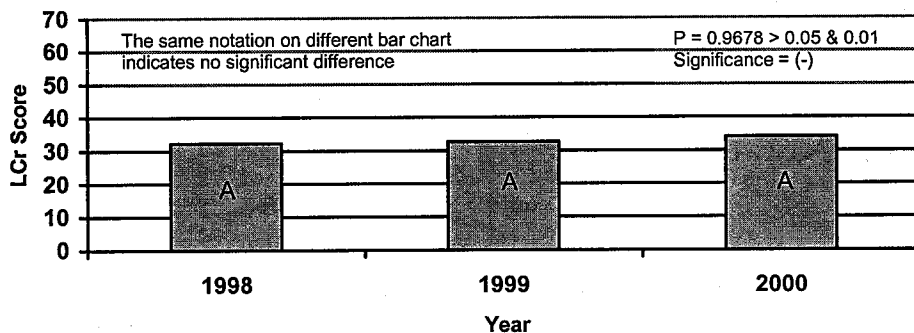

Figure 31. Change on live crown ratio within the different year in *S. polyandra* plantation, Pulau Laut, 1998 - 2000

**Change on crown condition of *S. polyandra* in natural forest, Pulau Laut**

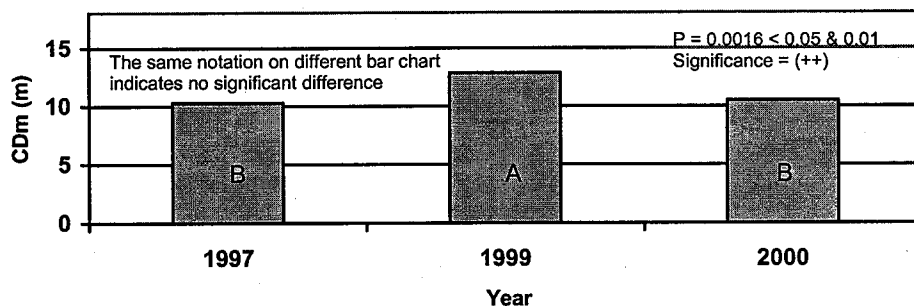

Figure 32. Change on crown diameter within the different year in *S. polyandra* of natural forest, Pulau Laut, 1997-2000

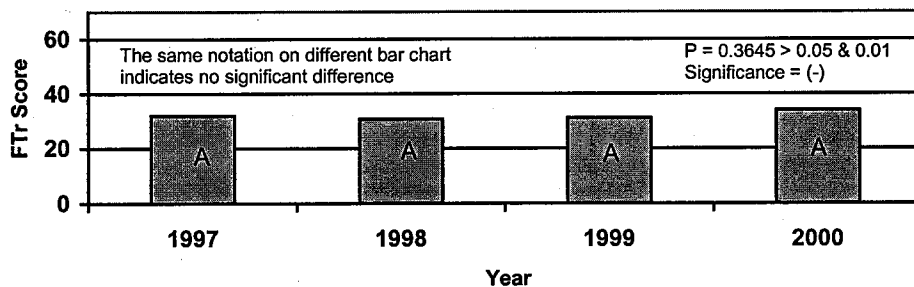

Figure 33. Change on foliage transparency within the different year in *S. polyandra* of natural forest, Pulau Laut 1997-2000

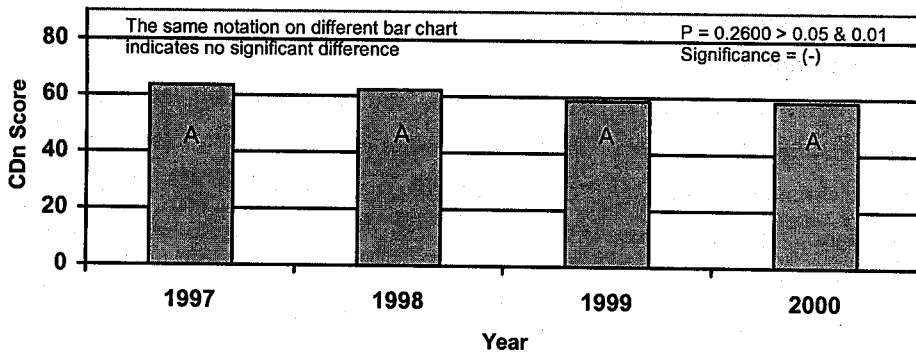

Figure 34. Change on crown density within the different year in *S. polyandra* of Natural Forest, Pulau Laut, 1997 - 2000

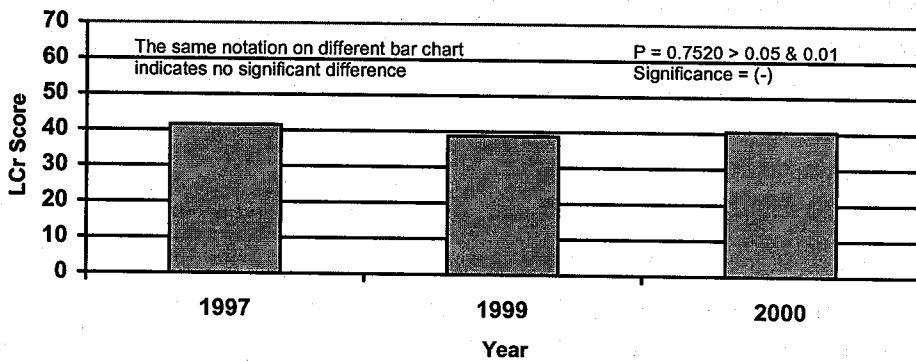

Figure 35. Change on live crown ratio within the different year in *S. polyandra* of Natural Forest, Pulau Laut, 1997 - 2000

Based on statistical analysis, the significant changes were shown by foliage transparency (Fig. 21 and 29), crown density (Fig. 22 and 26) and crown diameter (Fig. 32). It was believed that during 3 year period there were changes on crown condition. However, if the data are corrected by 10 % rule of acceptable range, according to the defined method (Cline-Steven, 1995), the average change was then insignificant difference. Thus the changes on various crown parameters within 3 years assessment period, especially natural forest in Jambi, were considered small and insignificant. It happened that natural forest in the study sites has come to a steady development.

### **3.3. Application of the method**

#### **3.3.1. Relevancy**

The important role of plant crown either intrinsically or externally is undoubtedly understandable. Crown condition may reflect the vigor and affect microclimate. The selected variables (CDm, LCr, CDn, FTr and CDb) are complementary to reflect the visual crown vigor. Therefore, the use of the crown variables in a quantitative crown assessment is scientifically sound.

#### **3.3.2. Measurability and tools needed**

The defined crown parameters, using ordinary tools, were proven to be measurable under field condition of Indonesian tropical rain forest. Crown diameter, on its vertical projection on ground, may be measured by using ordinary measuring tape. A simple designed crown card may be useful, especially for trainees, to assess the live crown ratio, crown density and foliage transparency. Ordinary binocular may be required, when there is unclear sight, to confirm deciduous from dieback symptom.

#### **3.3.3. Applicability**

The defined method for a quantitative crown assessment, although with multi parameters, is logically acceptable. If well educated, such method may be practiced under Indonesian Tropical Rain Forest. To practice assessing crown parameters is sometimes difficult due to possible damage of seedlings and saplings, which could be minimized through careful moving from site to site in the plots.

#### **3.3.4. Interpretability**

As a parameter, the crown variables, was measurable and in some extent interpretable. To make it more meaningful, therefore, further criterion on plant crown needs to be defined.

#### **3.3.5. Organization**

To be able measuring and assessing all crown parameters effectively, field crews have to be organized in such way so that each crew may do his / her assigned task. In practice, to measure and assess crown parameters requires at least three members. One of members usually the most senior, is the leader and the other two are the members. In practice, so far, ordinary local forestry workers were recruited. Briefing and operational exercises amongst the crews, especially to the local workers, need to be done prior to the commencement of actual measurement and assessment. Two local recruited crews have to measure the crown diameter using two bright color-flagging sticks and ordinary measuring tape. After completing a measurement of a crown diameter, one of them, has

to send the figure for further record to the leader through a loud shouting. In some cases they have to consult the leader. The crew leader has the following tasks i.e. assessing and recording the rest of the crown parameters, providing guide and problem solving and doing a check on their measurement.

### **3.3.6. Common problems**

Common difficulties in applying the defined method to assess tree crown parameters, occurred on the following condition:

- Multi layers canopy may cause unclear view to upper crown position.
- Dense understory vegetation, moreover with thorny plants may produce inaccessible points.
- Tree with crown dominating liana may cause difficulty in estimating FTr and CDn scores. In such case, tree crown part being dominated by liana crown was excluded as missing crown in assessing CDn.
- Unsteady ground slope may cause difficulty in assessing LCr score
- Poor weather may cause almost impossible to measure crown parameters

Only the last mentioned condition is unavoidable, for the others a way out could be found

### **3.3.7. Common comments from trainees**

- It was realized by the trainees, that practicing the method on tree growing on an open space crown was an easy assessment but when practicing on the real situation difficulties were encountered. Such difficulty mostly occurred at the beginning. However, more exercises gradually produce a better measurement.
- Five parameters to indicate crown condition were considered as complicated measure and time consuming. Therefore, for the purpose of forest monitoring in operation, trainees expect there will be another simple measure. However, trainees realized that such method was scientifically acceptable. Therefore, such method could be used for an intensive research rather than for practical monitoring.

As it was proven some crown parameters are complementary to other parameters. In case of limited facility, the use of some crown parameters may be cancelled.

- Most crown parameters were subjective based assessment. The trainees very often questioned such way of measurement. The measurement could be done using the recent available measuring tools, probably when a better accuracy measuring tools have been invented, such subjectivity could be minimized. Subjectivity in such assessment, at least at the present time, is unavoidable. It has been proven, that there was a way out to minimize it, such as by applying two crews to assess the same parameters, then a compromised figure would be produced. Through time of exercising and practicing the method, one may obtain the real skill in assessing

crown parameters. The defined FHM system covers the quality assurance, including crew certification.

### 3.3.8. Common mistakes by trainees

- First step in assessing crown density is determining the imagined normal shape, if there is a missing crown part, the next step is estimation of the missing part. The present crown density score is then corrected with missing part by reading the crown density card. Usually most crew personnel under training directly assessed crown density score without checking if there was a missing crown part.
- Inclusion of crown gap in assessing foliage transparency mostly happened.

### 3.3.9. Plot size

In Indonesia, it was a common practice that vegetation analyses were done on square plots instead of circular. It was described in the earlier section that INDO-FHM plots are circular (see Figure 1). A cluster consists of 4 circular plots covering 4 x 0.40682 Ha to represent 4000 Ha of a polygonal area. Each plot with radius of 17.95 m has circular plot, in the center, with radius of 7.32 m. The smaller plot is then called sub plot and the larger is called annular plot.

Crown indicator of all poles and tree levels was assessed in the sub plot and annular plot, respectively. Using the collected data of tree crown indicator, the two plot sizes, were then evaluated for its effectiveness. It was proven that, based on crown indicator data, the two plot sizes were no significant difference (Table 3). For the purpose of efficiency, sub plot size is much more efficient than annular, therefore sub plot size with radius of 7.32 m may be recommended for further crown indicator assessment.

Table 3. Correlation between sub plot, annular plot, and crown parameter, Pulau Laut and Jambi, 1999

No.	Location	Crown Parameters	p-value	S1 / S2	Duncan Test	Level of Significance
1.	Pulau Laut (natural forest)	Crown diameter wide	0.87	S1 S2	A 9.46 A 9.44	No Significant at 5% and 1%
		Crown diameter 90°	0.89	S1 S2	A 7.62 A 7.61	No Significant at 5% and 1%
		Live crown ratio	0.84	S1 S2	A 40.44 A 39.82	No Significant at 5% and 1%
		Crown density	0.44	S1 S2	A 60.74 A 59.31	No Significant at 5% and 1%
		Foliage transparency	0.67	S1 S2	A 35.73 A 36.58	No Significant at 5% and 1%
		Dieback	0.08	S1 S2	A 3.15 A 2.34	No Significant at 5% and 1%

Table 3. (Continuation)

No.	Location	Crown Parameters	p-value	S1 / S2	Duncan Test	Level of Significance
2.	Jambi (natural forest)	Crown diameter wide	0.78	S1 S2	A 8.69 A 8.38	No Significant at 5% and 1%
		Crown diameter 90°	0.74	S1 S2	A 6.98 A 6.67	No Significant at 5% and 1%
		Live crown ratio	0.80	S1 S2	A 36.72 A 34.33	No Significant at 5% and 1%
		Crown density	0.72	S1 S2	A 57.55 A 55.99	No Significant at 5% and 1%
		Foliage transparency	0.64	S1 S2	A 22.91 A 24.09	No Significant at 5% and 1%
		Dieback	0.33	S1 S2	A 3.51 A 1.06	No Significant at 5% and 1%

Note : S1 : Sub-plot ; S2 : Annular-plot ; p-value : probability value

#### IV. CONCLUSIONS

1. Either intrinsically or externally crown may be one of the important indicators of forest sustainability.
2. Crown parameters i.e. crown diameter, live crown ratio, crown density, foliage transparency and dieback in Forest Health Monitoring Program are environmentally sound and scientifically approved, specially in assessing forest stand health.
3. In assessing forest stand structure and stand dynamic, crown parameters should be complementary to canopy density parameter.
4. assessing forest stand dynamic and stand structure, crown parameters may be complementary to canopy parameters.
5. In assessing forest tree vitality / vigor, crown parameters may be complementary to damage parameters.
6. In assessing growth / productivity, crown size may be complementary to stem diameter / basal area.
7. Crown parameter assessment as part of forest health monitoring method may be applicable to Indonesian tropical rain forest.
8. Circular plot with radius 7.32 m, in assessing crown conditions of a forest stand, is appropriate enough instead of larger plot.

#### ACKNOWLEDGEMENT

This Technical Report No. 28 on the **Assessment on Crown Indicators of Forest Health Monitoring** has been prepared to fulfill Objective 1 point 2.2 of the Work-plan of ITTO Project PD 16/95 Rev. 2 (F): Forest Health Monitoring to Monitor the Sustainability of Indonesian Tropical Rain Forest.

The authors would like to thank ITTO, Ministry of Forestry (GOI), PT. INHUTANI II, PT. Asialog Concession Holder and Perum Perhutani Government Forest Enterprise for their support. Appreciation also goes to the Project Steering Committee members for their suggestions.

## REFERENCES

- Cline, Steven P. (ed). 1995. Environmental Monitoring and Assessment Program: Forest Health Monitoring. Quality Assurance Project Plan for Detection Monitoring Project. EPA 620/R-95/002. U.S. Environmental Protection Agency, Office of Research and Development, Washington, D.C. pp: 5.28 – 5.29
- ITTO. 1998. Criteria and Indicators for Sustainable Management of Natural Tropical Forests. ITTO Policy Development Series No 7. Yokohama.
- ITTO. 1999. Manual for the Application of Criteria and Indicators for Sustainable Management of Natural Tropical Forests ; Part B / Forest Management unit Indicators. ITTO Policy development Series No.10. Yokohama.
- Kasno, and Supriyanto. 2001. Crown Damage due to Logging Activity in Forest Health Monitoring. FHM Technical Report No.21. SEAMEO-BIOTROP. Bogor.
- Kozlowski, T.T. 1962. Tree Growth. University of Wisconsin, The Ronald Press Company. New York.
- Nuhamara, S.T. Kasno and Irawan, U.S. 2001. Assessment on Damage Indicators in Forest Health Monitoring. FHM Technical Report No.18. SEAMEO-BIOTROP. Bogor.
- Nuhamara, S.T. and Kasno. 2001. Stem Damage due to Logging in Forest Health Monitoring. FHM Technical Report No.19. SEAMEO-BIOTROP. Bogor.
- Oliver, C. D. and B. C. Larson. 1990. Forest Stand Dynamics. McGraw-Hill Inc. Tokyo.
- Supriyanto and Kasno. 2001. Assessment of Canopy Density Indicator Using Spherical Densimeter in Forest Health Monitoring. Technical Report No 20. SEAMEO-BIOTROP. Bogor.
- Tallent-Halsell, N.G. (ed). 1994. Forest Health Monitoring 1994 Field Methods Guide. EPA/620/R-94. U.S.Environmental Protection Agency, Washington, D.C. pp : 2.1 – 2.30
- USDA Forest Service. 1997. Forest Health Monitoring 1997 Field Methods Guide. USDA Forest service, National Forest Health Monitoring Program, Triangle Park, NC 27709. pp: 2.1 – 2.30



# EARLY WARNING OF CHANGES IN CANOPY CONDITION OF OVERSTORY TREES

*Technical Report No. 29*

Kasno  
Simon Taka Nuhamara  
Supriyanto  
Uhaedi Sutisna  
I Wayan Susi Dharmawan

## ABSTRACT

A study on the possible early warning of changes in canopy condition of overstory trees was carried out by overlaying INDO-FHM cluster plots on NFI cluster plots in the areas of PT. Sumpol Timber, South Kalimantan, and PT Asialog, Jambi. The objectives of this study were to evaluate the effectiveness of selected indicators, and to investigate the possible complementary of INDO-FHM method on NFI method in assessing the sustainability of Indonesian tropical rain forest. The results showed that the INDO-FHM method may provide significant contribution to NFI method in assessing the sustainability of Indonesian tropical rain forest. The inclusion of crown diameter as a crown indicator in the detection and monitoring program may indicate basal area, while the life crown ratio may indicate stand density. To obtain a sensitive image in the detection of early warning changes on canopy condition, the use of better technology, such as radar photography, is needed, and therefore is recommended.

**Key words:** *Canopy, indicator, growth, crown*

## I. INTRODUCTION

In 1989 the Government of Indonesia initiated the National Forest Inventory (NFI) Project on different areas in Indonesia. This project was technically assisted by FAO. The objective of this project is to provide information on the location and extent of the main forest types, to estimate the standing volumes and growth, and to assess the status and change of the forest. The project includes Forest Resources Assessment (FRA), Forest Resources Monitoring (FRM), Digital Image Analysis System (DIAS) and Geographic Information System (GIS).

However, the project did not specifically assess biodiversity as one of the keys of sustainable forest management as suggested by ITTO 1991 Guidelines for well-managed tropical ecosystems. Several relevant indicators are resource security, the continuity of timber production, the conservation of flora and fauna, an acceptable level of environmental impact and socio-economic benefit. The indicators of well-managed forest ecosystem must be equally defined by the environmental, economic as well as social attributes.

Forest Health Monitoring (FHM) was first developed in the U.S. in 1991. The FHM is an environmental approach to evaluate a forest ecosystem in terms of the condition,

changes, trends, causal agents and mechanisms, and finally to monitor the condition and changes in forest ecosystems. It is a ground-based estimate of the condition and trends in the forests, by monitoring the proportions of forest population that are in poor, sub nominal, nominal or optimal condition of each indicator.

Since the recent decades, there has been a significant shift on forestry paradigm. The increasing demand to forest and awareness on forestry have stimulated the paradigm shift. Forest has been the principle source of timber, however it has multi function. Both wood and non timber forest products including intangible benefits have to receive attention proportionally from stake holders. To make our forest plays the defined function optimally, the available base line data of a forest is urgently needed.

The INDO-FHM project covered field activities to assess the forest health, of which may be indicated by various indicators. Overlaying FHM cluster-plots on NFI cluster plots in the area of PT Sumpol Timber was aimed at knowing the effectiveness of the selected indicators, especially crown indicator, early warning of changes in canopy condition of overstory trees in further detection of monitoring program. It was also designed to compare the system with the NFI system.

## II. MATERIALS AND METHODS

### 2.1. NFI plot arrangement

To quantify the standing stock as the forest change over time, the NFI applies the remote sensing techniques and the systematic field sampling method. The field samples are cluster plots consisting of 3 by 3-square plots of 100 meters in size and 500 meters apart of which 8 at the edges and 1 at the center are treated as temporary and hidden permanent sample plots, respectively (Figure 1).

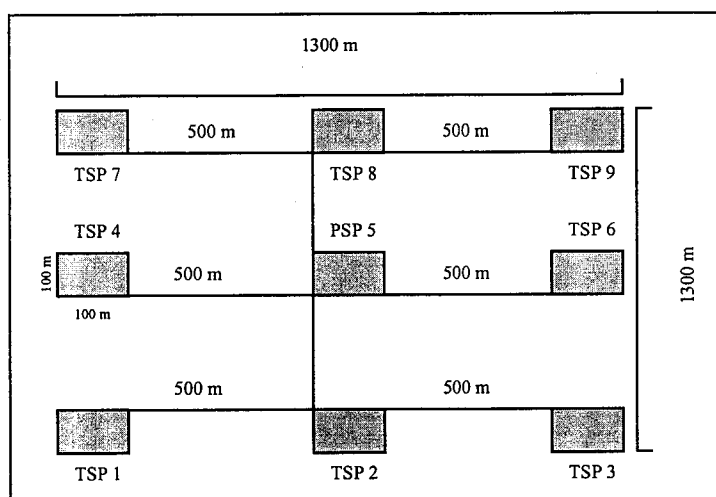

Figure 1. National Forest Inventory Plot System  
TSP : Temporary Sampling Plot PSP : Permanent Sampling Plot (Hidden Plot)

## 2.2. FHM plot arrangement

Figure 2 shows an illustrated arrangement of INDO-FHM plots. A cluster plot consisting of 4 plots representing 4000 ha of hexagonal areas (Tallent-Hatsell, 1996: USDA FS, 1997).

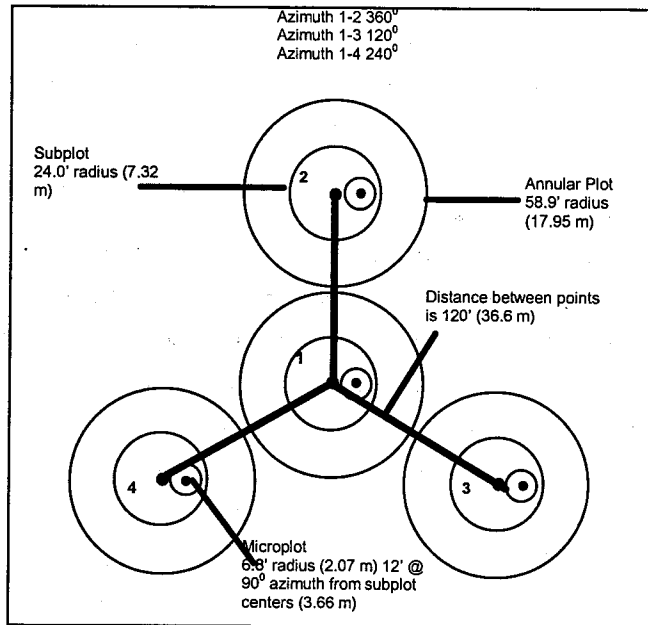

Figure 2. Four INDO-FHM Plots Arrangement Forming a Cluster

## 2.3. Overlaid FHM plots on NFI plots

Forest Health Monitoring cluster plot was overlaid within NFI cluster plot (Figure 3).

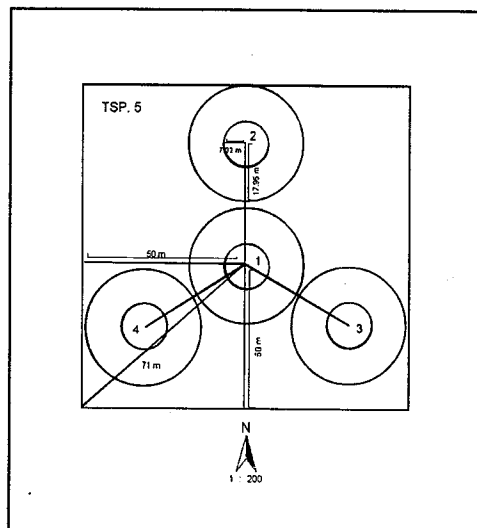

Figure 3. The Overlaid FHM Plot on NFI Permanent Sampling Plot (PSP)

#### **2.4. Location of plots**

FHM cluster plot number 9 and 8 were established and overlaid to NFI cluster plot No. 503209620 (West – East : 503, South – North : 2096, zone : 20) and 503209600 (West – East : 503, South – North : 2096, zone : 00) respectively (Figure 4). Those plots are located at PT Sumpol Timber, South Kalimantan. FHM cluster plot number 4 was established and overlaid on NFI cluster plot No. 573209760 (West – east: 573, South – North: 2097, zone: 60) (Balai Inventarisasi dan Pemetaan Hutan Wilayah V, 1996). FHM cluster plot number 4 is located at PT Asialog, Jambi.

#### **2.5. Data collection procedure**

Standard procedure of data collection of INDO-FHM followed the Forest Health Monitoring Field Methods Guide (International-Indonesia) issued by the EPA, 1997 (USDA FS, 1997). All poles with stem diameter (DBH) 10 cm up and trees with 20 cm up were tagged, mapped, measured on various parameters and recorded. The most recent (1998) data recorded from NFI cluster No 503209620 and No.573209700 were obtained from the Agency of Forest and Estate Crops Planning, Ministry of Forestry and Estate Crops. The NFI data was recorded at 3 months before FHM plots establishment. Satellite imagery (Figure 4) of PT Sumpol Timber area and its surrounding, which was taken in 1991, was purchased from LAPAN (National Aerospace and Aviation Institute).

The NFI data covered the satellite image, forest tree species, stand structure and stem diameter / basal area. Such data are recorded every five years through census of ground checking to estimate the growth as well as stand stock volume. Meanwhile, INDO-FHM data covered site quality indicated mainly by soil indicator, forest vitality indicated by crown and damage indicators, biodiversity indicated by vegetation indicator, stand structure and stand dynamic indicated by stem, crown, vegetation and canopy indicators. Crown indicator was assessed through 5 parameters i.e. crown diameter, live crown ratio, foliage transparency, crown density and crown dieback. Such parameters were applied on pole and tree level. Seedling and sapling vigors, using crown parameters, may be assessed. INDO-FHM has another indicator i.e. socio-economic, however such indicator is still in its early development.

All bio-physical parameters and assessment procedures of FHM method have been prepared as a field method guide and revised periodically by USDA-Forest Service for further improvement. One of the editions, specifically prepared to make INDO-FHM project implemented, was the 1997's edition (FHM Field Method Guide, International-Indonesia 1997).

## 2.6. Data analysis

Both NFI ground check data and INDO-FHM data as well as satellite imagery were matched for examining the possible comparability and compatibility.

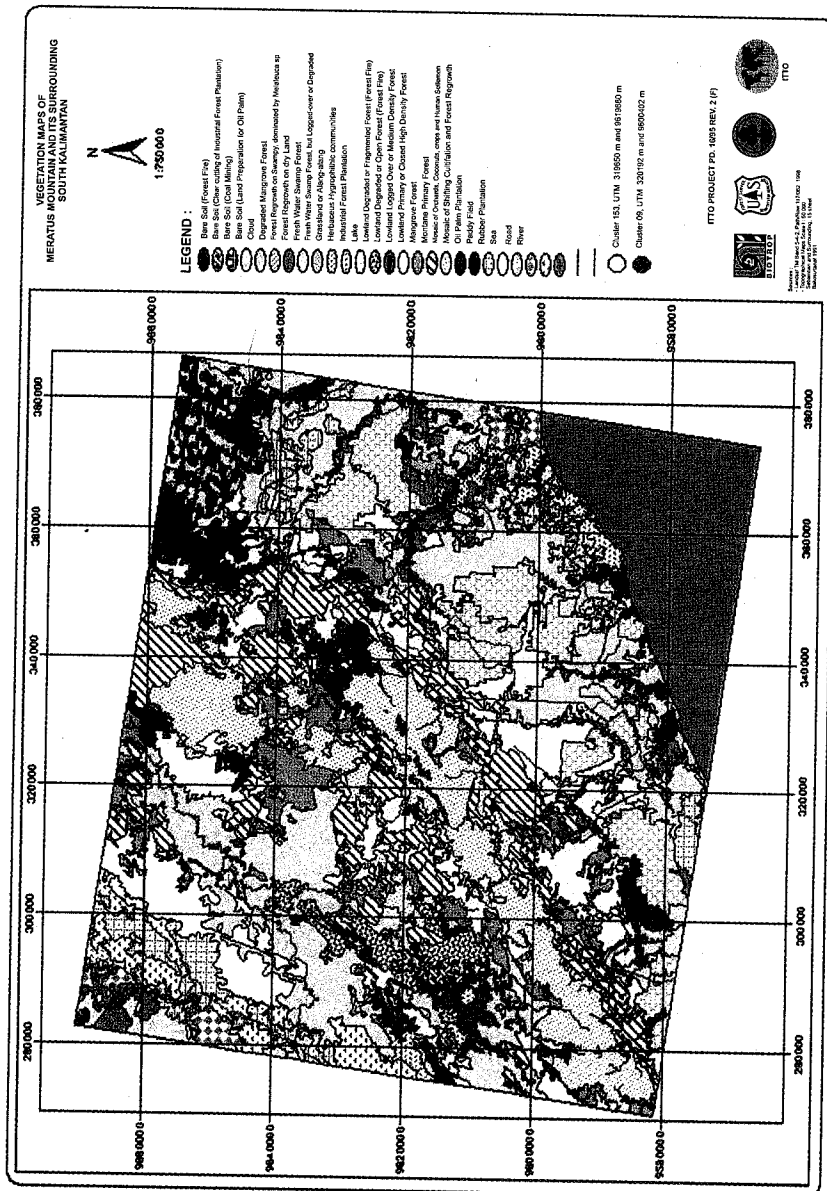

Figure 4. Vegetation Map of Meratus Mountain and Its Surrounding South Kalimantan

Crown parameters used in this study were crown diameter, live crown ratio, crown density, foliage transparency and dieback were then related to basal area and stand density. Aside from crown parameters, INDO-FHM has other parameters to be

measured i.e. canopy density that was assessed by using spherical densiometer. Hence it was related to basal area while satellite imagery was related to the canopy density and biodiversity was assessed through minimum curve area and diversity indexes, etc. Vegetation map in the study sites was produced by digital interpretation of satellite image purchased from LAPAN (National Aerospace and Aviation Institute). The vegetation map produced from satellite image was then overlaid with canopy density and crown diameter for compatibility and comparability. Some parameters were examined to see the possible correlation. Minitab for Window was used in the analysis of the collected data (Ryan, et al. 1985)

### III. RESULTS AND DISCUSSIONS

NFI system applied satellite digital image to assess the stand stock volume through canopy density parameter and ground checking, and to assess stand density and basal area excluding crown parameters. Aside from crown parameters, Forest Health Monitoring Method has another various parameters as presented in brief in Table 1.

Table 1. Indicator / Parameter Covered by NFI and INDO – FHM in Assessing Sustainability of Indonesian Tropical Rain Forest

No.	Item	NFI	INDO-FHM	Note
1.	Vegetation Coverage	V	-	Satellite Image
2.	Vegetation Structure	V	V	Seedling, sapling, pole, tree
3	Understory vegetation	-	V	Moss, lichen, fern, shrub
3.	Biodiversity	-	V	Minimum Curve Area
4.	Stem Diameter / Basal Area	V	V	Diameter at breast height
5.	Tree Map	V	V	Tagged
6.	Crown	-	V	5 parameters
7.	Damage	-	V	Location, type, severity
8.	Canopy	-	V	Spherical densiometer
9.	Site Quality (Soil)	-	V	Phys., Chem., Org. matter
10.	Socio – Economic	-	V	Still in early development

INDO-FHM covers more parameters than NFI as shown in Table 1. Such broaden parameters in FHM method is developed to anticipate the increasing need as the result of forestry paradigm shift. People nowadays expect more benefits from forest ecosystem,

in which they pursue various form of forest service. As a result, more related base line data are required to achieve the goal of sustainable forest management.

Table 2 presents the correlation between stand density (N) and basal area (BA) with crown parameters (live crown ratio = LCr, foliage transparency = FTr, crown density = CDn , crown dieback = CDb, crown diameter = CDm), the case in FHM cluster plots in the area of PT. Sumpol Timber, 1999.

It was shown that foliage transparency has quite strong role on basal area, however, further test indicated that the coefficient determination between basal area and live crown ratio was very small (see Table 3). It means that the model accuracy of foliage transparency to indicate basal area was inappropriate.

Table 2 has another indication of the important role of live crown ratio as well as crown density on stand density. Further test indicated that coefficient determination between live crown ratio and stand density was little bit higher than crown density. Similar fact was shown by the case of FHM cluster 2 and 4 in the area of PT. Asialog, Jambi (Table 4). The followings were the regression stand density and basal area :

$$N = - 25.5 + 1.11 \text{ LCr} \dots\dots\dots\text{FHM Cluster 4, Jambi}$$

$$N = 28.0 + - 45,2 \text{ LCr} \dots\dots\dots\text{FHM Clusters 8 and 9, PT.Sumpol Timber}$$

$$\text{BA} = - 0.0271 + 0.000150 \text{ CDm} \dots\dots\text{FHM Cluster 2 , Jambi}$$

$$\text{BA} = - 988 + 230 \text{ CDm} \dots\dots\dots\text{FHM Cluster 4, Jambi.}$$

Table 2. Correlation Analysis Between Number of Stem (N), Basal Area (BA) and Crown Parameters in the Case of FHM Cluster Plot in the Area of PT. Sumpol Timber, 1999

Cluster	Parameter	BA		LCr		FTr		CDn		CDb		CDm	
		r	p	r	p	r	p	r	p	r	p	r	p
8, 9	BA	1.00	0.00	0.01	0.98	0.73	0.04	0.43	0.29	0.19	0.65	0.06	0.88
	N	0.26	0.53	0.66	0.08	0.35	0.39	0.61	0.11	0.83	0.01	0.43	0.29

Note : r = coefficient correlation, p = probability value

Table 3. The Relationships Between Basal Area and Crown Parameters at PT. Asialog and PT. Sumpol Timber

Basal Area (BA)	Crown parameters	R <sup>2</sup> (Coefficient of determination)		
		Jambi, cluster 2	Jambi, cluster 4	PT.Sumpol Timber
BA	Live crown ratio	1.6 %	0.0 %	8.0 %
	Crown density	2.4 %	1.2 %	0.1 %
	Foliage transparency	0.1 %	12.1 %	0.4 %
	Crown diameter	48.4 %	47.9 %	23.0 %

Table 4. The Relationships Between Number of Trees and Crown Parameters (Live Crown Ratio, Crown Density) at PT. Asialog and PT. Sumpol Timber

Number of Trees (N)	Crown parameters	R <sup>2</sup> (Coefficient of determination)		
		Jambi, cluster 2	Jambi, cluster 4	PT.Sumpol Timber
N	Live crown ratio	43.9 %	60 %	43.5 %
	Crown density	21.4 %	60.5 %	37.7 %

Table 5 presents the correlation between basal area, stand density and canopy density. Based on the correlation analysis it was shown that correlation between basal area, stand density and live crown ratio, foliage transparency, crown density, crown dieback and crown diameter were very low. It means that both basal area and crown parameters are necessarily needed in assessing forest productivity as well as tree growth. It was then concluded that the use of basal area and stand density parameters in assessing forest stand quality, as applied by NFI, was considered inadequate. Therefore, the inclusion of canopy density, as well as other crown parameters namely live crown ratio, crown diameter, crown density, foliage transparency, crown dieback may substitute the drawback of NFI method.

The case of vegetation map which was derived from satellite image, 1991, it may be harmful to compare it to both canopy density and crown parameters due to different time of data collection. Canopy density and crown parameters were collected in the year 1999. However, assuming that data collection was done in the same time, it is believed that such satellite image will not show detailed information compared to ground checking assessment, except the vegetation map is derived from higher resolution such as using radar photography.

There was so much difference in tree identification due to different references. The list of tree species is presented in appendix 1.

Table 5. Correlation Analysis Between Stand Density, Canopy Density and Basal Area in FHM cluster plot no. 8 and 9, PT. Sumpol Timber, 1999

Cluster	Plot	No. of Stem (N) (absolute)	Basal Area (m <sup>2</sup> )	Canopy Density %	Parameter	Basal Area		Canopy Density	
						r	p	r	p
8	1	3	0.612	82.39	N	0.26	0.52	0.36	0.37
	2	3	0.286	36.41					
	3	4	0.177	64.12	Canopy Density	0.18	0.67	1.00	0.00
	4	10	0.701	99.11					
Average			0.444	70.51					



Table 5. (Continuation)

Cluster	Plot	No. of Stem (N) (absolute)	Basal Area (m <sup>2</sup> )	Canopy Density %	Parameter	Basal Area		Canopy Density	
						r	p	r	p
9	1	20	1.494	84.66	N	-0.26	0.52	0.36	0.37
	2	17	1.928	76.56		Canopy Density	0.18	0.67	1.00
	3	13	0.945	45.36					
	4	13	1.316	95.51					
Average			1.421	75.52					

Note : r = coefficient correlation, p = probability value

#### IV. CONCLUSIONS

1. INDO-FHM method, in assessing Indonesian tropical rain forest, may compliment the NFI method.
2. To obtain more accurate image of vegetation map as well as comparable map, the use of radar photography is suggested.
3. The use of crown diameter as a crown parameter, in assessing tree growth as well as forest stand stock volume, may be an appropriate function for basal area.
4. The use of live crown ratio as a crown parameter, in assessing forest stand structure, may be an appropriate function for stand density.

#### V. RECOMMENDATION

To reach more confidence assessment of the forest stand sustainability, the series of measurement of crown parameters as FHM method is needed.

In NFI method the use of satellite digital image was not able to assess crown diameter as well as stem diameter of individual forest tree. Therefore, to overcome this problem, the use of radar image photography or videography image is one of the solutions.

#### ACKNOWLEDGEMENT

This Technical Report No. 29 on the **Early Warning of Changes in Canopy Condition of Overstory Trees** has been prepared to fulfill Objective 4 point 5.1, 5.2, and 5.7 of the Work-plan of ITTO Project PD 16/95 Rev. 2 (F) : Forest Health Monitoring to Monitor the Sustainability of Indonesian Tropical Rain Forest.

The authors would like to thank ITTO, Ministry of Forestry (GOI) and PT. SUMPOL Forest Concession Holder for their support. Appreciation also goes to the Project Steering Committee members for their suggestions.

#### REFERENCES

- Balai Inventarisasi dan Pemetaan Hutan Wilayah V Banjarbaru, 1996. Laporan Hasil Reevaluasi Permanent Sample Plot (PSP) Inventarisasi Hutan Nasional Desa Bukit Baru Kabupaten Dati II Kota Baru Propinsi Kalimantan Selatan. No. 32/VII – BIBHUT V – NFI / 1996. Balai Inventarisasi dan Pemetaan Hutan Wilayah V Banjarbaru. Banjarbaru.
- Ryan, B.F., Joiner, B.L. and Ryan, T.A. 1985. –Minitab Handbook. 2 ed. Duxbury Press. Boston.
- Tallent-Hatsell, N.G. (ed). 1994. Forest Health Monitoring 1994 Field Methods Guide. EPA/620/R-94/027. U.S. Environmental Protection Agency, Washington. D.C.
- USDA Forest Service. 1997. Forest Health Monitoring Field Method Guide (International – Indonesia edition). USDA Forest Service. National Forest Health Monitoring Program, Research Triangle Park, NC 27709.

Annex 1. Crown Parameters, DBH and Basal area on FHM Cluster-Plots, Sumpol

ID	Cl.	Plot	FHM ID	Species Name	LCr	CDn	CDb	FTr	CDm	DBH99	BA
08.1.01/SUM	8	1	Antcad	<i>Anthocephalus cadamba</i>	55	20	10	35	112	42.30	1,404.59
08.1.02/SUM	8	1	Neolan	<i>Neonauclea lanceolata</i>	25	75	5	25	310	24.00	452.16
08.1.03/SUM	8	1	Plaval	<i>Planchonia valida</i>	45	60	5	40	865	73.70	4,263.88
08.2.03/SUM	8	2	Neolan	<i>Neonauclea lanceolata</i>	55	55	0	45	1075	47.50	1,771.16
08.2.04/SUM	8	2	Plaval	<i>Planchonia valida</i>	55	65	5	35	595	21.60	366.25
08.2.05/SUM	8	2	Plaval	<i>Planchonia valida</i>	35	20	5	80	377	30.40	725.47
08.3.01/SUM	8	3	Cebsp1	<i>Cephalomappa</i> sp.	35	10	0	85	23	18.00	254.34
08.3.03/SUM	8	3	Diomac	<i>Diospyros macrophylla</i>	45	15	10	85	675	23.70	440.93
08.3.07/SUM	8	3	Duroxl	<i>Durio oxleyanus</i>	60	50	20	30	375	30.60	735.04
08.3.08/SUM	8	3	Duracu	<i>Durio acutifolius</i>	45	35	0	65	510	20.70	336.36
08.4.01/SUM	8	4	Bacjav	<i>Baccaurea javanica</i>	80	25	20	75	605	11.00	94.98
08.4.03/SUM	8	4	Mirsp1	<i>Mirtaceae</i> sp.	75	80	0	20	325	14.30	160.52
08.4.04/SUM	8	4	Alshel	<i>Alseodaphne helophila</i>	75	65	0	35	425	13.50	143.07
08.4.05/SUM	8	4	Bursp1	<i>Burseraceae</i> sp.	85	45	0	15	333	10.70	89.87
08.4.06/SUM	8	4	Euszwa	<i>Eusideroxylon zwageri</i>	65	60	0	40	580	10.60	88.20
08.4.09/SUM	8	4	Duracu	<i>Durio acutifolius</i>	20	35	0	65	110	60.00	2,826.00
08.4.10/SUM	8	4	Machyp	<i>Macaranga hypoleuca</i>	20	35	0	55	67	21.60	366.25
08.4.11/SUM	8	4	Ficner	<i>Ficus nervosa</i>	30	30	20	70	115	44.00	1,519.76
08.4.12/SUM	8	4	Artani	<i>Artocarpus anisophyllus</i>	25	65	0	35	72	26.00	530.66
08.4.13/SUM	8	4	Diomac	<i>Diospyros macrophylla</i>	40	80	0	20	64	39.00	1,193.99
09.1.01/SUM	9	1	Sachor	<i>Saccopetalum horsfieldii</i>	30	40	0	40	96	11.20	98.47
09.1.02/SUM	9	1	Aglsp1	<i>Aglala</i> sp.	30	35	0	45	465	13.30	138.86
09.1.03/SUM	9	1	Eupmal	<i>Euphoria malaiensis</i>	40	65	0	35	750	14.00	153.86
09.1.04/SUM	9	1	Eugsp1	<i>Eugenia</i> sp.	30	65	0	25	765	16.70	218.93
09.1.05/SUM	9	1	Beiwig	<i>Beilschmiedia wightii</i>	45	55	0	45	415	11.50	103.82
09.1.06/SUM	9	1	Garsp1	<i>Garcinia</i> sp.	60	55	0	45	535	11.50	103.82
09.1.07/SUM	9	1	Swispi	<i>Swintonia spicifera</i>	40	55	0	45	575	15.00	176.63
09.1.08/SUM	9	1	Gankin	<i>Ganua kingiana</i>	60	65	0	35	435	11.50	103.82
09.1.09/SUM	9	1	Apofal	<i>Aporusa falcifera</i>	25	55	0	45	395	12.20	116.84
09.1.10/SUM	9	1	Neokin	<i>Neoscortechinia kingii</i>	20	55	0	45	685	39.20	1,206.26
09.1.11/SUM	9	1	Polgla	<i>Polyalthia glauca</i>	30	65	0	35	790	26.80	563.82
09.1.12/SUM	9	1	Girsub	<i>Gironniera subaequalis</i>	25	55	0	45	1015	45.50	1,625.15
09.1.13/SUM	9	1	Terbel	<i>Terminalia bellerica</i>	30	40	0	55	475	22.20	386.88
09.1.14/SUM	9	1	Payacu	<i>Payena acuminata</i>	20	45	0	55	515	32.00	803.84
09.1.15/SUM	9	1	Dipgra	<i>Dipterocarpus grandiflorus</i>	20	55	0	45	610	32.70	839.39
09.1.16/SUM	9	1	Swispi	<i>Swintonia spicifera</i>	15	55	0	45	600	31.00	754.38

ID	Cl.	Plot	FHM ID	Species Name	LCr	CDn	CDb	FTr	CDm	DBH99	BA
09.1.17/SUM	9	1	Ctepar	<i>Ctenolophon parvifolius</i>	20	40	0	60	1060	52.00	2,122.64
09.1.19/SUM	9	1	Ilebog	<i>Ilex bogoriensis</i>	20	55	0	45	800	38.00	1,133.54
09.1.20/SUM	9	1	Dipcau	<i>Dipterocarpus caudiferus</i>	20	65	0	35	1160	59.20	2,751.14
09.1.21/SUM	9	1	Dipcau	<i>Dipterocarpus caudiferus</i>	20	55	0	35	920	44.30	1,540.55
09.2.01/SUM	9	2	Quearg	<i>Quercus argentea</i>	50	75	0	25	545	13.90	151.67
09.2.02/SUM	9	2	Diomal	<i>Diospyros malabarica</i>	5	45	0	55	215	10.70	89.87
09.2.03/SUM	9	2	Horsp1	<i>Horsfieldia</i> sp.	10	65	0	35	210	10.50	86.55
09.2.04/SUM	9	2	Eugsp1	<i>Eugenia</i> sp.	50	65	0	35	1275	62.00	3,017.54
09.2.05/SUM	9	2	Trimal	<i>Trigonopleura malayana</i>	40	65	0	35	490	21.00	346.19
09.2.06/SUM	9	2	Eugsp1	<i>Eugenia</i> sp.	30	45	0	55	640	60.00	2,826.00
09.2.07/SUM	9	2	Swispi	<i>Swintonia spicifera</i>	50	65	0	35	630	48.00	1,808.64
09.2.08/SUM	9	2	Eugsp1	<i>Eugenia</i> sp.	55	65	0	35	970	34.00	907.46
09.2.09/SUM	9	2	Diomal	<i>Diospyros malabarica</i>	10	35	0	65	750	68.00	3,629.84
09.2.10/SUM	9	2	Gluren	<i>Gluta renghas</i>	50	75	0	25	745	37.00	1,074.67
09.2.11/SUM	9	2	Dipcau	<i>Dipterocarpus caudiferus</i>	40	75	0	25	985	55.50	2,418.00
09.2.12/SUM	9	2	Trimal	<i>Trigonopleura malayana</i>	30	65	0	35	495	27.70	602.32
09.2.13/SUM	9	2	Barsp1	<i>Barringtonia</i> sp.	40	55	0	45	605	22.50	397.41
09.2.14/SUM	9	2	Duracu	<i>Durio acutifolius</i>	60	75	0	25	835	29.00	660.19
09.2.15/SUM	9	2	Sanlae	<i>Santiria laevigata</i>	35	65	0	35	555	22.70	404.50
09.2.16/SUM	9	2	Permac	<i>Persea macrophylla</i>	40	55	0	45	820	20.20	320.31
09.2.17/SUM	9	2	Agltom	<i>Aglia tomentosa</i>	50	65	0	35	885	26.20	538.86
09.3.01/SUM	9	3	Canlit	<i>Canarium littorale</i>	20	55	0	35	545	12.00	113.04
09.3.02/SUM	9	3	Litcyc	<i>Lithocarpus cyclophorus</i>	25	55	0	45	365	13.00	132.66
09.3.03/SUM	9	3	Paldas	<i>Palaquium dasyphyllum</i>	20	55	0	45	350	13.90	151.67
09.3.04/SUM	9	3	Dipcau	<i>Dipterocarpus caudiferus</i>	50	35	0	65	315	14.00	153.86
09.3.05/SUM	9	3	Dipcau	<i>Dipterocarpus caudiferus</i>	10	35	0	55	610	36.00	1,017.36
09.3.06/SUM	9	3	Shosp1	<i>Shorea</i> sp.	15	55	0	35	655	28.00	615.44
09.3.08/SUM	9	3	Memsp1	<i>Memecylon</i> sp.	35	55	0	45	420	22.10	383.40
09.3.09/SUM	9	3	Diodur	<i>Diospyros durionoides</i>	15	55	0	45	830	41.00	1,319.59
09.3.10/SUM	9	3	Shosp1	<i>Shorea</i> sp.	15	55	0	45	775	66.20	3,440.22
09.3.12/SUM	9	3	Terbel	<i>Terminalia belerica</i>	50	65	0	35	405	22.40	393.88
09.3.13/SUM	9	3	Dipcau	<i>Dipterocarpus caudiferus</i>	10	45	0	55	320	22.20	386.88
09.3.14/SUM	9	3	Hydpol	<i>Hydnocarpus polypetalus</i>	60	65	0	35	615	27.40	589.35
09.3.15/SUM	9	3	Dipcau	<i>Dipterocarpus caudiferus</i>	15	35	0	65	765	31.00	754.38
09.4.01/SUM	9	4	Hopmen	<i>Hopea mengarawan</i>	40	35	0	65	680	16.00	200.96
09.4.02/SUM	9	4	Aposp1	<i>Aporusa</i> sp.	45	45	0	55	355	10.00	78.50
09.4.03/SUM	9	4	Horsp1	<i>Horsfieldia</i> sp.	40	55	0	45	145	11.20	98.47
09.4.04/SUM	9	4	Garsp1	<i>Garcinia</i> sp.	40	55	0	45	695	17.60	243.16

ID	Cl.	Plot	FHM ID	Species Name	LCr	CDn	CDb	FTr	CDm	DBH99	BA
09.4.05/SUM	9	4	Sanrub	<i>Santiria rubiginosa</i>	10	75	0	25	885	31.50	778.92
09.4.08/SUM	9	4	Dipcau	<i>Dipterocarpus caudiferus</i>	10	55	0	45	725	42.50	1,417.91
09.4.09/SUM	9	4	Permac	<i>Persea macrophylla</i>	15	65	0	35	865	30.80	744.68
09.4.10/SUM	9	4	Agisp1	<i>Aglaia</i> sp.	40	55	0	45	795	20.20	320.31
09.4.11/SUM	9	4	Tercit	<i>Terminalia citrina</i>	35	45	0	55	905	33.20	865.26
09.4.12/SUM	9	4	Gluwal	<i>Gluta wallichii</i>	30	45	0	55	315	43.00	1,451.47
09.4.13/SUM	9	4	Shojoh	<i>Shorea johorensis</i>	15	55	0	35	1085	62.30	3,046.81
09.4.14/SUM	9	4	Tercit	<i>Terminalia citrina</i>	15	45	0	55	1415	67.00	3,523.87
09.4.15/SUM	9	4	Pimmac	<i>Pimelodendron macrocarpum</i>	55	65	0	35	1155	22.40	393.88











ITTO



ISBN 979-8275-11-X

ISBN 979-8275-14-4

**ITTO PROJECT NO. PD 16/95 REV. 2 (F)**

**FOREST HEALTH MONITORING TO MONITOR  
THE SUSTAINABILITY OF INDONESIAN TROPICAL RAIN FOREST**

**MOF - ITTO - SEAMEO BIOTROP - USDA Forest Service**

**VOLUME III**